



AC Fan Mini Air Handling Unit -Ceiling Concealed Type



Turn To The Experts

Carrier is a leading global provider of innovative HVAC, refrigeration, fire, security and building automation technologies.

Supported by the iconic Carrier name, the company's portfolio includes industry-leading brands such as Carrier, Kidde, Edwards, LenelS2 and Automated Logic.

Carrier's businesses enable modern life, delivering efficiency, safety, security, comfort, productivity and sustainability across a wide range of residential, commercial and industrial applications.



In 1998, Time magazine named Dr. Carrier one of its 20 most influential builders and titans of the 20th century.



Directory

Features and Advantages	4
Features	6
Nomenclature	7
General Data	8
Jet Type Unit Design Selection	13
Dimension	14
Wiring Diagrams	17
Installation	18
Precautions For Installation And Use	19
Maintenance And Service	21

5 Clean and Hygienic, Operating at Low Noise

The unit is equipped with an integral drain pan. After being processed against corrosion using the technology of static spraying plastics, the entire drain pan can preserve heat. The drain pan covers on the bottom board of the cabinet. During installation, a water discharge slope will be established to ensure that condensate water can be discharged properly during unit operating, thus avoiding bacteria. Double-wall foaming boards form the envelop enclosure of the unit, which not only achieves good thermal insulation effects, but also reduces the unit operation noise.



6 Intelligent Integrated Control

Mechanical & electrical integration control enables integrated control of fan, motor, and water valve. The control system is composed of low-voltage apparatuses and temperature controllers from internationally well-known brands. If the unit is equipped with a temperature controller with communication function, the unit can access third-party control systems, such as a building automation and control system, to enable remote and network-based unit monitoring.

The control cabinet is equipped with multiple protection technologies, such as short circuit, power loss, and overloading to ensure that the unit operates stably. In addition, the unit reserves diversified external interlocking, such as control signals of fire valves, fresh air valves, and switching type water valves.

Integrated control can save energy of the chiller, while ensuring comfortable room temperature.



7 Dedicated Model Selection and Checking Software

CARRIER uses a professional model selection software to select a unit model. Featuring user-friendly interfaces, the software facilitates model selection.

The software can also address the needs of customers for model checking in non-standard operating conditions, deliver the best configuration solution, output a professional model selection report, and raise design efficiency.

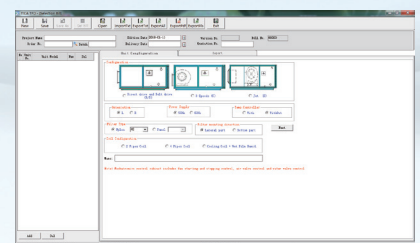

Features



Patented structure, low air leakage rate

Carrier patented design of labyrinth seal structure which provides low air leakage formed by using aluminum sections with concave and convex chamfer at joints of AHU body and tightening with bolts and nuts.



Robust structural design

Carrier AHU has an aluminum alloy frame and a hidden metal inner frame, in which the former constitutes a rigid body with high resistance to torsion by using a tenon structure and tightening with bolts and nuts, while the latter greatly improves the strength of the unit.

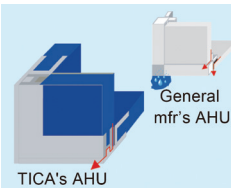

Prevention of cold bridge and rust

All metals inside Carrier labyrinth AHU are isolated from those outside by means of polyurethane foaming and specially designed seals, eliminating insulation strips commonly used in general AHUs and therefore preventing the cold bridge. Frames of aluminum sections are embedded around all panels, completely isolating corners of metal panel from air and moisture and thereby preventing rust spot on panels.

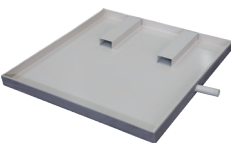

No water leakage

The unit adopts the one-piece drain pan, which is covered by seamlessly integrated insulation materials after overall coating by spraying equipment of advanced German technology. The drain pan installed on the unit base can act as prevention of water leakage both during installation and use.



Mechatronic control

The unit uses large LCD screen and touch keys and supports features such as one-key startup, automatic operation, and multi-status display. It is equipped with microcomputer of superb anti-interference ability. Major elements are reliable and quality products of world-famous brands including Carrier. In addition, there are a variety of outer interlocking accessories, and interfaces reserved for the fire valve, fresh air valve (starting and stopping simultaneously with the air supply motor), and water valve control.

Nomenclature

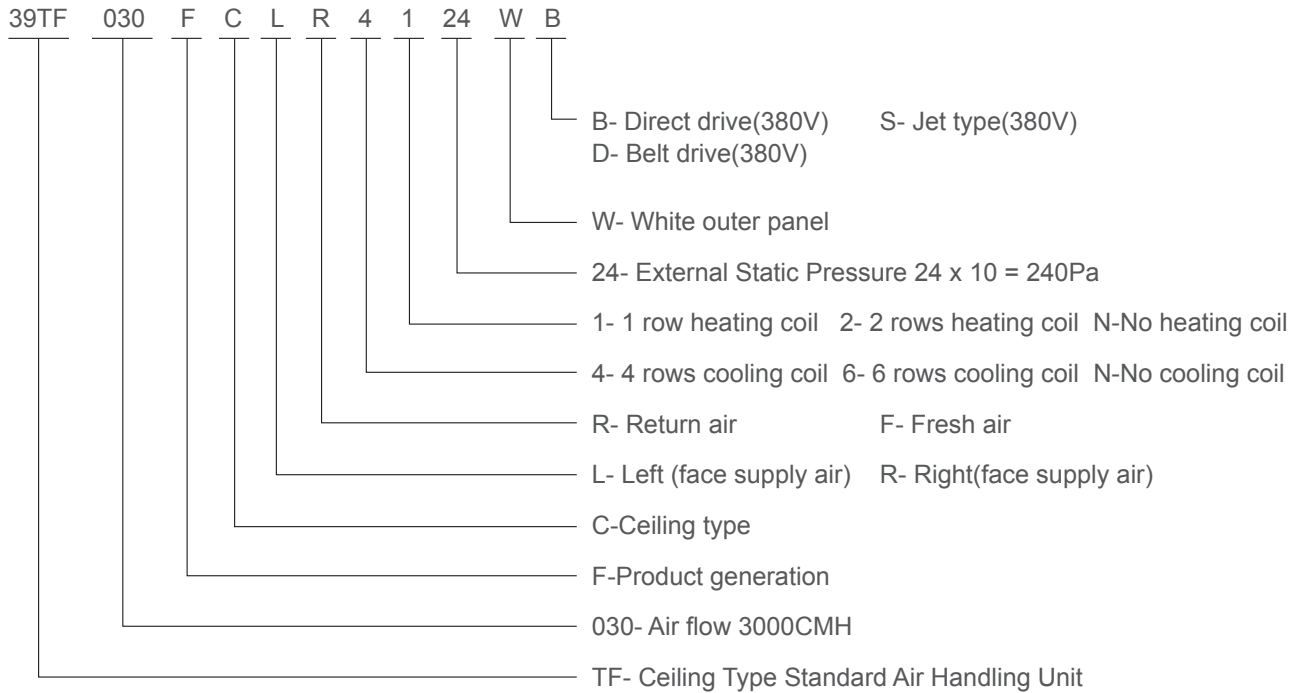

Method To Determine The Side Of Unit

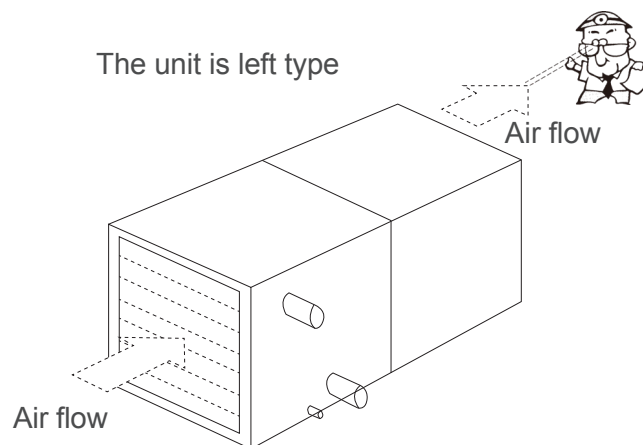

Facing the air flow, if the water piping is on the left, this is a left type unit” and “Facing the air flow, if the water piping is on the right, this is a right type unit

General Data

General Data - 39TF-B/D

Return air condition

Model	Air Flow	4Rows						6Rows						ESP	Sound Level	Condensate Water Pipe	Power Supply	Drive Type
		Rated Cooling Capacity	Rated Heating Capacity	Water Flow Rate	Water Pressure Drop	Motor Power	Chilled Water Pipe	Rated Cooling Capacity	Rated Heating Capacity	Water Flow Rate	Water Pressure Drop	Motor Power	Chilled Water Pipe					
39TF	m ³ /h	kW	kW	l/s	kPa	kW	DN	kW	kW	l/s	kPa	kW	DN	Pa	dB(A)	DN		
010	1000	5.1	10.2	0.24	3.0	0.18	32	7.2	12.4	0.34	8.8	0.18	32	80	53	25	380V 3N~ 50Hz	Direct Drive
015	1500	8.3	15.2	0.40	9.0	0.32	32	11.0	18.5	0.52	19.5	0.32	32	80	53	25		
020	2000	11.5	21.2	0.55	11.0	0.32	32	14.9	25.3	0.71	26.0	0.32	32	80	55	25		
025	2500	14.4	26.0	0.69	18.0	0.55	32	18.2	30.8	0.87	38.0	0.55	32	120	56	25		
030	3000	17.5	32.0	0.83	31.0	0.75	32	22.0	37.3	1.05	62.0	0.75	32	160	59	25		
040	4000	23.4	41.5	1.13	60.0	1.1	40	30.1	49.1	1.43	49.5	1.1	40	200	60	25	380V 3N~ 50Hz	Belt Drive
050	5000	28.3	51.4	1.37	40.0	1.5	40	35.2	61.8	1.68	78.0	1.5	40	200	62	25		
060	6000	34.5	61.7	1.64	47.0	1.5	40	43.7	73.9	2.08	44.0	2.2	40	200	63	25		
070	7000	40.3	71.3	1.92	66.0	2.2	40	49.4	85.3	2.35	59.0	2.2	50	240	64	25		
080	8000	46.2	83.1	2.20	58.0	2.2	40	57.6	98.3	2.74	56.0	3.0	50	240	64	25		
090	9000	52.1	93.1	2.48	79.0	3.0	40	64.8	110.3	3.09	25.4	3.0	50	280	66	25		
105	10500	59.9	108.1	2.85	51.0	3.0	50	75.1	135.3	3.58	39.0	4.0	50	280	67	25		
120	12000	69.3	131.7	3.30	57.0	4.0	50	85.8	161.1	4.09	44.0	4.0	50	280	68	25		
135	13500	76.8	146.6	3.66	56.0	4.0	50	102.3	176.4	4.87	42.0	4.0	65	320	68.5	32		
150	15000	85.3	162.8	4.06	51.0	5.5	50	108.5	189.7	5.17	39.0	5.5	65	320	69	32		

★ NOTE:

- Cooling capacity is based on the following:
 - Inlet and outlet water temperature: 7°C/12°C
 - Air entering condition: 27°C DB/19.5°C WB
- Heating capacity is based on the following (with the same water flow rate as cooling mode):
 - Inlet and outlet water temperature: 60°C/50°C
 - Air entering condition: 15°C DB
- The manufacturer reserves the rights to make changes to the above specifications without prior notice.
- The water flow in the above table indicates the cold water supply flow. Because the hot water supply flow is smaller than cold water supply flow, cold water supply flow is provided in the table for your reference to select the water pump.

Fresh air condition

Model	Air Flow	4Rows						6Rows						ESP	Sound Level	Condensate Water Pipe	Power Supply	Drive Type
		Rated Cooling Capacity	Rated Heating Capacity	Water Flow	Water Pressure Drop	Motor Power	Chilled Water Pipe	Rated Cooling Capacity	Rated Heating Capacity	Water Flow	Water Pressure Drop	Motor Power	Chilled Water Pipe					
39TF	m ³ /h	kW	kW	l/s	kPa	kW	DN	kW	kW	l/s	kPa	kW	DN	Pa	dB(A)	DN	380V 3N~ 50Hz	Direct Drive
010	1000	13.9	13.2	0.66	16.0	0.18	32	15.8	15.6	0.75	31.0	0.18	32	80	53	25		
015	1500	18.7	18.4	0.93	42.0	0.32	32	24.5	23.7	1.17	80.0	0.32	32	80	53	25		
020	2000	27.0	27.5	1.29	49.0	0.32	32	31.2	31.3	1.49	35.0	0.32	32	80	55	25		
025	2500	30.8	31.8	1.47	79.0	0.55	32	40.3	39.3	1.92	58.0	0.55	40	120	56	25		
030	3000	39.9	40.9	1.90	48.0	0.75	40	45.8	45.1	2.18	80.0	0.75	40	160	59	25		
040	4000	49.7	51.1	2.37	38.0	1.1	40	63.8	61.8	3.04	76.0	1.1	50	200	60	25		
050	5000	64.5	64.0	3.07	63.0	1.5	50	75.4	70.3	3.59	51.0	1.5	50	200	62	25		
060	6000	72.7	75.5	3.46	74.0	1.5	50	92.6	91.9	4.41	57.0	2.2	50	200	63	25		
070	7000	84.1	87.1	4.00	17.0	2.2	50	105.6	104.8	5.03	80.0	2.2	65	240	64	25		
080	8000	99.0	101.7	4.71	14.4	2.2	50	120.7	119.7	5.75	30.0	3.0	65	240	64	25		
090	9000	111.0	113.8	5.29	19.0	3.0	65	137.3	135.3	6.54	41.0	3.0	65	280	66	25		
105	10500	133.1	133.3	6.34	31.0	3.0	65	160.2	157.9	7.63	57.9	4.0	80	280	67	25		
120	12000	149.4	155.1	7.12	35.0	4.0	65	185.2	180.4	8.20	68.8	4.0	80	280	68	25		
135	13500	165.8	180.2	7.90	33.0	4.0	80	222.6	213.4	9.84	63.0	4.0	80	320	68.5	32		
150	15000	184.2	200.2	8.77	31.0	5.5	80	244.7	237.1	10.65	56.6	5.5	80	320	69	32		

★ NOTE:

- Cooling capacity is based on the following:
 - Inlet and outlet water temperature: 7°C/12°C
 - Air entering condition: 35°C DB/28°C WB
- Heating capacity is based on the following (with the same water flow rate as cooling mode):
 - Inlet and outlet water temperature: 60°C/50°C
 - Air entering condition: 7°C DB
- The manufacturer reserves the rights to make changes to the above specifications without prior notice.
- The water flow in the above table indicates the cold water supply flow. Because the hot water supply flow is smaller than cold water supply flow, cold water supply flow is provided in the table for your reference to select the water pump.

■ General Data-39TF-B/D Unit ESP and Power

39TF	Air Flow (m ³ /h)	Cooling Coil Rows	ESP (Pa)						
			80	120	160	200	240	280	320
010	1000	4	0.18	0.18	0.25	0.32			
		6	0.18	0.25	0.32	0.32			
015	1500	4	0.32	0.32	0.32	0.32	0.37		
		6	0.32	0.32	0.32	0.37	0.45		
020	2000	4	0.32	0.32	0.37	0.37	0.45	0.45	
		6	0.32	0.37	0.37	0.45	0.45	0.55	
025	2500	4	0.45	0.55	0.55	0.75	0.75	0.75	
		6	0.55	0.55	0.75	0.75	0.75	0.75	
030	3000	4	0.55	0.75	0.75	0.75	0.75	1.1	1.1
		6	0.75	0.75	0.75	0.75	1.1	1.1	1.1
040	4000	4	1.1	1.1	1.1	1.1	1.1	1.1	1.5
		6	1.1	1.1	1.1	1.1	1.1	1.5	1.5
050	5000	4	1.1	1.5	1.5	1.5	1.5	2.2	2.2
		6	1.5	1.5	1.5	1.5	2.2	2.2	2.2
060	6000	4	1.5	1.5	1.5	1.5	2.2	2.2	2.2
		6	1.5	1.5	1.5	2.2	2.2	2.2	2.2
070	7000	4	1.5	1.5	2.2	2.2	2.2	2.2	2.2
		6	1.5	2.2	2.2	2.2	2.2	2.2	3.0
080	8000	4	2.2	2.2	2.2	2.2	2.2	3.0	3.0
		6	2.2	2.2	2.2	2.2	3.0	3.0	3.0
090	9000	4	2.2	2.2	2.2	2.2	2.2	3.0	3.0
		6	2.2	2.2	2.2	2.2	3.0	3.0	3.0
105	10500	4	3.0	3.0	3.0	3.0	3.0	3.0	4.0
		6	3.0	3.0	3.0	3.0	3.0	4.0	4.0
120	12000	4		3.0	3.0	3.0	4.0	4.0	4.0
		6		3.0	3.0	4.0	4.0	4.0	4.0
135	13500	4				3.0	3.0	4.0	4.0
		6				3.0	4.0	4.0	4.0
150	15000	4				4.0	4.0	4.0	5.5
		6				4.0	4.0	5.5	5.5

★ NOTE:

1. This table lists the motor power value of each type of unit under different external static pressures. (Unit: kW)

General Data-39TF-S

Return air condition

Model	Air Flow	4Rows						6Rows						Condensate Water Pipe	Power Supply	Drive Type
		Rated Cooling Capacity	Rated Heating Capacity	Water Flow	Water Pressure Drop	Motor Power	Chilled Water Pipe	Rated Cooling Capacity	Rated Heating Capacity	Water Flow	Water Pressure Drop	Motor Power	Chilled Water Pipe			
39TF	m ³ /h	kW	kW	l/s	kPa	kW	DN	kW	kW	l/s	kPa	kW	DN	DN	380V 3N~ 50Hz	Direct Drive
010	1000	5.1	10.2	0.24	3.0	0.18	32	7.2	12.4	0.34	8.8	0.18	32	25		
020	2000	11.5	21.2	0.55	11.0	0.32	32	14.9	25.3	0.71	26.0	0.32	32	25		
030	3000	17.5	32.0	0.83	31.0	1.1	32	22.0	37.3	1.05	62.0	1.1	32	25		
040	4000	23.4	41.5	1.13	60.0	1.1	40	30.1	49.1	1.43	49.5	1.1	40	25		
050	5000	28.3	51.4	1.37	40.0	1.5	40	35.2	61.8	1.68	78.0	2.2	40	25		
060	6000	34.5	61.7	1.64	47.0	1.5	40	43.7	73.9	2.08	44.0	2.2	40	25		
070	7000	40.3	71.3	1.92	66.0	1.5	40	49.4	85.3	2.35	59.0	2.2	50	25		
080	8000	46.2	83.1	2.20	58.0	2.2	40	57.6	98.3	2.74	56.0	3.0	50	25		
090	9000	52.1	93.1	2.48	79.0	2.2	40	64.8	110.3	3.09	25.4	3.0	50	25		
105	10500	59.9	108.1	2.85	51.0	3.0	50	75.1	135.3	3.58	39.0	3.0	50	25		
120	12000	69.3	131.7	3.3	57.0	4.0	50	85.8	161.1	4.09	44.0	4.0	50	25		

★ NOTE:

- Cooling capacity is based on the following:
 - Inlet and outlet water temperature: 7°C/12°C
 - Air entering condition: 27°C DB/19.5°C WB
- Heating capacity is based on the following(with the same water flow rate as cooling mode):
 - Inlet and outlet water temperature: 60°C/50°C
 - Air entering condition: 15°C DB
- The manufacturer reserves the rights to make changes to the above specifications without prior notice.
- The water flow in the above table indicates the cold water supply flow. Because the hot water supply flow is smaller than cold water supply flow, cold water supply flow is provided in the table for your reference to select the water pump.
- The external static pressure is 0 Pa. If an air duct is required, please specify when you make the order.

Fresh air condition

Model	Air Flow	4Rows						6Rows						Condensate Water Pipe	Power Supply	Drive Type
		Rated Cooling Capacity	Rated Heating Capacity	Water Flow	Water Pressure Drop	Motor Power	Chilled Water Pipe	Rated Cooling Capacity	Rated Heating Capacity	Water Flow	Water Pressure Drop	Motor Power	Chilled Water Pipe			
39TF	m ³ /h	kW	kW	l/s	kPa	kW	DN	kW	kW	l/s	kPa	kW	DN	DN	380V 3N~ 50Hz	Direct Drive
010	1000	13.9	13.2	0.66	16.0	0.18	32	15.8	15.6	0.75	31.0	0.18	32	25		
020	2000	27.0	27.5	1.29	49.0	0.32	32	31.2	31.3	1.49	35.0	0.32	32	25		
030	3000	39.9	40.9	1.90	48.0	1.1	40	45.8	45.1	2.18	80.0	1.1	40	25		
040	4000	49.7	51.1	2.37	38.0	1.1	40	63.8	61.8	3.04	76.0	1.1	50	25		
050	5000	64.5	64.0	3.07	63.0	1.5	50	75.4	70.3	3.59	51.0	2.2	50	25		
060	6000	72.7	75.5	3.46	74.0	1.5	50	92.6	91.9	4.41	57.0	2.2	50	25		
070	7000	84.1	87.1	4.00	17.0	1.5	50	105.6	104.8	5.03	80.0	2.2	65	25		
080	8000	99.0	101.7	4.71	14.4	2.2	50	120.7	119.7	5.75	30.0	3.0	65	25		
090	9000	111.0	113.8	5.29	19.0	2.2	65	137.3	135.3	6.54	41.0	3.0	65	25		
105	10500	133.1	133.4	6.34	31.0	3.0	65	160.2	157.9	7.63	57.9	3.0	80	25		
120	12000	149.4	155.1	7.12	35.0	4.0	65	185.2	180.4	8.20	68.8	4.0	80	25		

★ NOTE:

- Cooling capacity is based on the following:
 - Inlet and outlet water temperature: 7°C/12°C
 - Air entering condition: 35°C DB/28°C WB
- Heating capacity is based on the following(with the same water flow rate as cooling mode):
 - Inlet and outlet water temperature: 60°C/50°C
 - Air entering condition: 7°C DB
- The manufacturer reserves the rights to make changes to the above specifications without prior notice.
- The water flow in the above table indicates the cold water supply flow. Because the hot water supply flow is smaller than cold water supply flow, cold water supply flow is provided in the table for your reference to select the water pump.
- The external static pressure is 0 Pa. If an air duct is required, please specify when you make the order.

■ Separate Heating Coil

Return air condition

Model	Air Flow	1Row				2Rows			
		Rated Heating Capacity	Water Flow	Water Pressure Drop	Chilled Water Pipe	Rated Heating Capacity	Water Flow	Water Pressure Drop	Chilled Water Pipe
39TF	m ³ /h	kW	l/s	kPa	DN	kW	l/s	kPa	DN
010	1000	3.0	0.1	0.17	32	6.2	0.2	0.87	32
015	1500	4.3	0.1	0.19	32	9.9	0.3	2.1	32
020	2000	6.7	0.2	0.59	32	13.4	0.4	3.0	32
025	2500	8.2	0.2	0.63	32	16.4	0.4	3.3	32
030	3000	10.9	0.3	1.4	32	20.2	0.5	5.3	32
040	4000	14.8	0.4	1.5	32	27.7	0.7	6.5	32
050	5000	19.1	0.5	2.5	32	35.2	0.9	11.6	32
060	6000	23.2	0.6	3.0	32	43.0	1.1	14.2	32
070	7000	27.6	0.7	4.3	32	49.7	1.2	18.2	32
080	8000	31.5	0.8	4.0	32	57.3	1.4	18.2	32
090	9000	36.0	0.9	5.3	32	65.0	1.6	24.9	32
105	10500	42.6	1.1	8.4	32	76.4	1.8	34.0	32
120	12000	49.4	1.3	9.9	32	87.3	2.1	38.8	32
135	13500	55.6	1.5	9.8	32	98.2	2.4	36.2	32
150	15000	60.8	1.6	10.0	32	108.3	2.6	37.7	32

★ NOTE:

- Heating capacity is based on the following
 - Inlet and outlet water temperature: 60°C/50°C
 - Air entering condition: 15°C DB
- The manufacturer reserves the rights to make changes to the above specifications without prior notice.
- Pressure drop of heating coil is 20Pa per row.

Fresh air condition

Model	Air Flow	1Row				2Row			
		Rated Heating Capacity	Water Flow	Water Pressure Drop	Chilled Water Pipe	Rated Heating Capacity	Water Flow	Water Pressure Drop	Chilled Water Pipe
39TF	m ³ /h	kW	l/s	kPa	DN	kW	l/s	kPa	DN
010	1000	4.3	0.2	0.64	32	7.3	0.2	0.87	32
015	1500	6.3	0.2	0.69	32	11.6	0.3	2.1	32
020	2000	8.9	0.3	1.3	32	16.5	0.5	4.5	32
025	2500	10.9	0.3	1.4	32	20.2	0.5	4.9	32
030	3000	13.7	0.4	2.5	32	25.3	0.7	9.9	32
040	4000	18.3	0.5	2.3	32	33.7	0.9	10.3	32
050	5000	24.2	0.7	4.7	32	42.9	1.1	16.7	32
060	6000	29.1	0.8	5.1	32	51.4	1.3	19.2	32
070	7000	33.9	0.9	6.9	32	61.0	1.5	27.1	32
080	8000	39.3	1.1	7.2	32	69.7	1.7	25.7	32
090	9000	44.3	1.2	9.0	32	78.4	1.9	33.8	32
105	10500	52.4	1.4	13.0	32	93.0	2.3	52.5	32
120	12000	60.7	1.6	14.5	32	106.2	2.6	56.7	32
135	13500	67.3	1.8	13.6	32	119.5	3.0	54.0	32
150	15000	73.8	1.9	13.7	32	130.7	3.2	54.7	32

★ NOTE:

- Heating capacity is based on the following
 - Inlet and outlet water temperature: 60°C/50°C
 - Air entering condition: 7°C DB
- The manufacturer reserves the rights to make changes to the above specifications without prior notice.
- Pressure drop of heating coil is 20Pa per row.

Jet Type Unit Design Selection

The thermal performance parameter calculation of the ordinary ceiling type unit is the same with that of the jet type air handling unit adopting the spherical nozzle. Design selection mainly includes the calculation of air flow organization. For a specified project, the proper jet type air handling unit needs to be selected after the air supply distance, unit installation height, air supply temperature, and air supply volume are determined, and the cold and hot air flow supplied by the unit must meet the following requirements:

1. The cold and hot air are sent to the specified location.
2. The cold jet flow does not drop down during the supply process to avoid causing discomfort to people.
3. The hot air can be sent to the required distance and location.
4. Temperature difference meets the design requirement.

Design selection must take into account the mutual impact of the multiple air supply nozzles of the unit. The spread of the jet flow is approximately 0.4 times wider than the jet range. An appropriate configuration is to make the unit deployment density slightly smaller than the diffusion width. If the unit is installed closely to the ceiling, the impact of adhesion should also be considered. The jet range of the attached air flow is 1.4 times larger than the common air flow.

■ Jet Range Recommendation

Based on the performances of the unit and the spherical nozzle, the recommended horizontal air supply range (unit: m) of various types of air handling units is as follows:

39TF	010	020	030	040	050	060	070	080	090	105	120
Jet Range	14	21	21	21	25	22	28	30	32	28	31
Distance	20	27	27	27	31	28	34	36	38	34	37

★ NOTE:

1. The maximum spread width of the unit jet flow is about 40% of the jet range. Therefore, unit deployment should take into consideration the air flow spread angle, and the distance between units should not be too large.
2. The units can be deployed on a single side or on opposite sides. If neither the deployment can meet the jet range, an induction fan can be adopted to continue the air supply. The induction fan is deployed by every 4 to 6 meters in vertical direction, and by every 6 to 10 meters in horizontal direction.

Dimension

Direct drive (series B) – ceiling type

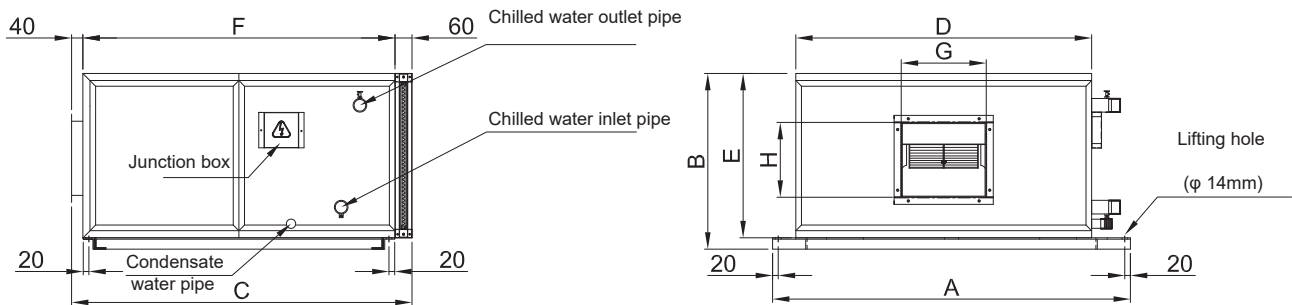

Model 39TF	A	B	C	D	E	F	G	J	Return air flange (Length×Width)	Outlet air flange (Length×Width)	Unit weight	
											4Rows	6Rows
010	717	545	900	553	505	800	302	232	493×445	302×232	50	57
015	867	545	900	703	505	800	302	275	643×445	302×275	57	63
020	927	620	900	763	580	800	302	275	703×520	302×275	71	81
025	1017	620	900	853	580	800	302	306	793×520	302×306	76	86

★ NOTE

1. If add heating coil, F need to plus 100mm.
2. The above weight and size do not include the built-in control cabinet.

Direct drive (series D) – ceiling type

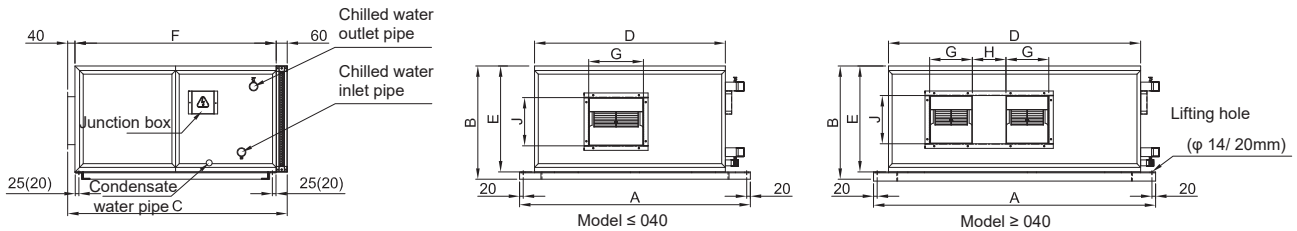

Model 39TF	A	B	C	D	E	F	G	H	J	Return air flange (Length×Width)	Outlet air flange (Length×Width)	Unit weight	
												4Rows	6Rows
030	1127	620	950	963	580	850	298	—	262	903×520	298×262	90	121
040	1357	620	950	1193	580	850	331	—	289	1133×520	331×289	99	129
050	1547	630	950	1383	580	850	232	184	262	1323×520	648×262	128	158
060	1652	690	950	1488	640	850	265	214	289	1428×580	744×289	139	180
070	1842	690	950	1678	640	850	331	264	289	1618×580	926×289	192	222
080	1772	780	950	1608	730	850	331	264	289	1548×670	926×289	231	271
090	1947	780	1050	1783	730	950	309	244	341	1723×670	862×341	270	305
105	2197	780	1050	2033	730	950	309	244	341	1973×670	862×341	279	309
120	2298	840	1050	2134	790	950	395	324	341	2074×730	1114×341	287	311
135	2248	940	1150	2084	890	1050	373	294	404	2024×730	1040×404	368	398
150	2218	1040	1150	2054	990	1050	373	294	404	1994×930	1040×404	372	414

★ NOTE

1. The value 25 (20) is the distance between the lifting hole and the outer edge of the unit base. It is 20 for 040 type and smaller type, and is 25 for types larger than 040. The diameter of 135 and 150 type lifting hole is Φ 20 mm.
2. The above unit size does not contain the heating coil. If the heating coil is required, the unit size F should be increased by 100 mm.
3. The above weight and size do not include the built-in control cabinet.

Jet (series S) – ceiling type

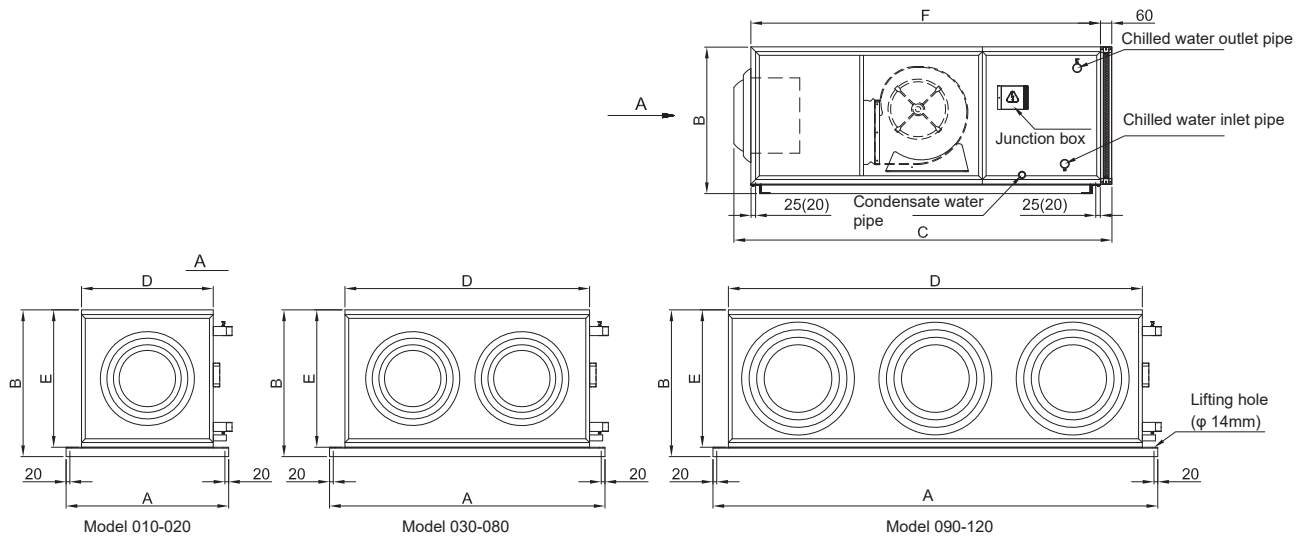

Model 39TF	A	B	C	D	E	F	Jet numbers	Jet model	OD	ID	Unit weight	
											4Rows	6Rows
010	717	545	1505	553	505	1400	1	315	384	190	129	134
020	927	620	1540	763	580	1400	1	400	467	230	154	161
030	1127	620	1555	963	580	1450	2	315	384	190	188	196
040	1357	620	1590	1193	580	1450	2	400	467	230	201	210
050	1547	630	1590	1383	580	1450	2	400	467	230	228	239
060	1652	690	1600	1488	640	1450	2	500	600	275	249	262
070	1842	690	1600	1678	640	1450	2	500	600	275	292	307
080	1772	780	1600	1608	730	1450	2	500	600	275	343	358
090	1947	780	1690	1783	730	1550	3	400	467	230	376	393
105	2197	780	1700	2033	730	1550	3	500	600	275	389	408
120	2298	840	1700	2134	790	1550	3	500	600	275	396	416

★ NOTE

1. 25(20) shows that the size of the hole for hoist apart from the outside 040 and under 040 is 20, above 040 is 25.
2. The above weight and size do not include the built-in control cabinet.

Wiring Diagrams

39TF-D/B/S

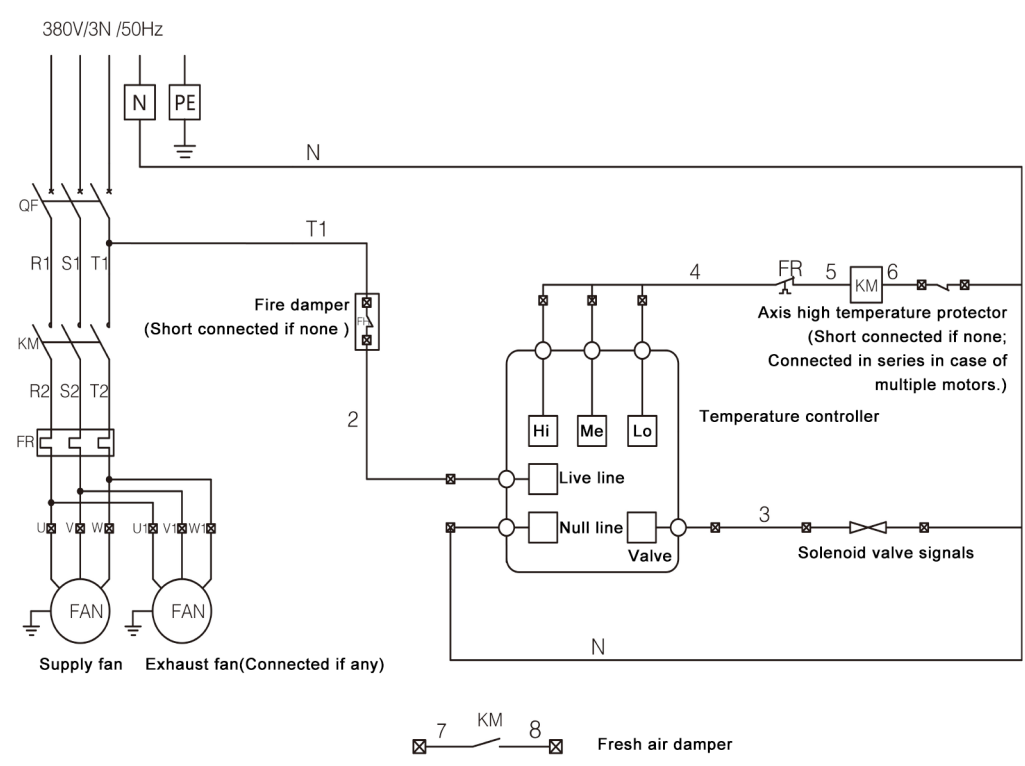

Installation

- Carefully check the unit for damage before installing it, and please contact the retailer for repair and replacement under any of the following conditions: impact or serious deformation of the unit, obvious scratch that affects the appearance of the unit panel or housing, and looseness or breakaway of the fan or motor.
- For the purpose of safety, hoist the ceiling-mounted unit firmly in the way as shown in the figure on the right, or load/unload and move it with a forklift, ensure the hoisting point is firm with sufficient strength to bear the unit weight and make sure the unit is level.
- Before wiring, check whether the power supply voltage, frequency and phase are consistent with the unit and ensure the power supply voltage deviation doesn't exceed $\pm 10\%$ of the rated voltage. Before starting the fan, get into the fan case and rotate the fan impeller by hand, carefully check whether there is any metal scraping sound and eliminate the abnormality if any. After switching on the power supply, start the fan, check whether the impeller rotates in the correct direction. In case of incorrect rotation direction, just change the phase sequence of the power supply incoming line.
- It is recommended that a plenum chamber be set at the unit air inlet/outlet, an air volume control valve on the air duct and a fire damper in accordance with fire control requirements. If an electric air volume control valve is installed, start the air valve actuator and then the fan, while close the fan and then the air valve actuator.

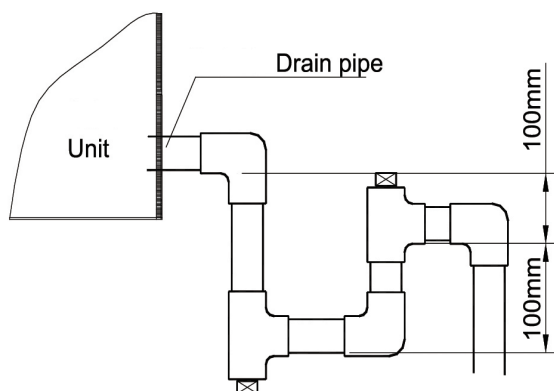
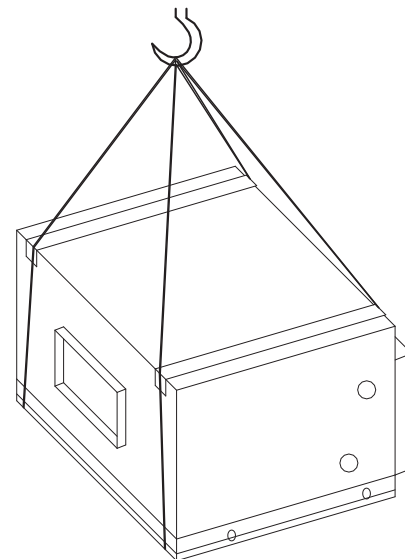

U Type Water Seal Installation

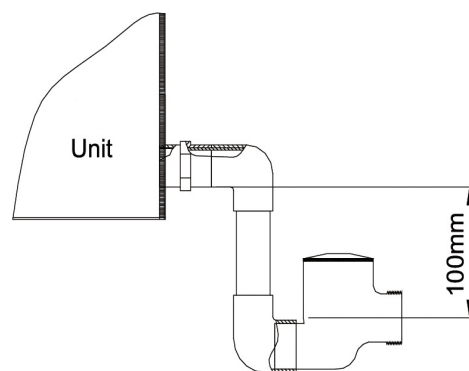

Ball Type Water Seal Installation

- Wash the water pipes before connecting them. Pay attention to the cold (hot) water inflow and outflow directions, connect the pipes as per the marks on the unit, and equip the unit water inlet pipe with a valve and a filter to adjust the flow. In case of overhauling, cut off the cold (hot) water source, prevent impurities from entering the heat exchanger so as not to block it, and use insulated water inlet and outlet pipes for thermal insulation.
- When connecting the water inlet and outlet pipes, fix them with a pipe tong and prevent them from being subject to a torsional force during operation. It is recommended that Teflon tape be used for sealing to avoid water leakage. Condensate water from the unit must be connected at a certain water seal height and drained into the sewer through a drain pipe as shown in the figure above.
- Never make the unit bear the weights of air duct, water pipes, etc. connected with it.
- Earth the unit reliably, and check whether the electric circuits are in good conditions and comply with the electric safety requirements.
- Make sure the unit is installed by professionals who are familiar with the product and relevant local rules and avoid impact, pressing and scratch during installation.

Precautions For Installation And Use

- Switch off the power supply when the unit doesn't operate for a long time or in winter.
- To avoid an electric shock, a fire and other possible injuries, always keep in mind the following rules and observe them:
- Never try to install or modify the A/C unit by yourself for improper operation (if any) may cause water leakage, electric shock and fire.
- Never connect the grounding wire of the A/C to the gas pipe, tap water pipe, lightning rod, etc.
- Use the accessories specified by the company and ask the manufacturer or authorized dealer to provide installation and technical services.
- Isolate the unit controller data line and the power supply line to avoid interference.
- Never damage the power supply line, and never turn on or off the A/C unit by plugging or unplugging the power supply.
- Never flush the A/C unit with water directly, otherwise, electric shock or other accidents may occur.
- Never try to repair by yourself for improper repair may cause operation fault or burnout to the unit; please contact the local branch or authorized service provider if repair is needed.
- The air conditioning unit shall not operate in corrosive gas environment, for instance, acid, alkali, salt mist, etc. Otherwise, it may lead to the damage to the unit enclosure, pipeline or electrical elements.
- The space around the unit shall be kept clean, dry and well-ventilated. In case the heat exchanger on the air side can be cleaned regularly (at the interval of 1~2 months), its good heat transfer effect can be maintained and the energy can be saved.
- The drain pipe must be laid according to the requirements in the Instruction to ensure smooth water drainage and proper measures for thermal insulation shall be taken to prevent the generation of condensate. The drain pipe must be inspected before the unit operates. In case of blockage, foreign matters must be eliminated to ensure smooth drainage of the condensate.
- The wiring of the power supply and the electrical system for the unit shall be inspected frequently to confirm whether the wiring is firm, whether electrical elements operate abnormally. In case of abnormalities, cause(s) for the failure are investigated and rectified. No forced startup shall be conducted before the cause(s) of failure are rectified.
- The minimum startup voltage of the unit must be kept above 90% of the rated voltage, the voltage during operation must be within $\pm 10\%$ of the rated voltage and the voltage difference among all phases shall be within $\pm 2\%$. Overvoltage or undervoltage will have adverse effect on the unit. Stable power supply shall be guaranteed and in case of unstable voltage, excessive current will be generated at the moment of unit startup for operation, and this may damage the unit motor.
- The unit maintenance and repair can only be conducted provided that the unit is shut down and it is disconnected with the power supply.
- In case of unit failure, it can only be started after causes for the failure are identified and eliminated and no forced startup shall be conducted before the failure is not eliminated.

- No short connection of the lines for the unit protection device shall be conducted. Otherwise, this may lead to the unit failure.
- The internal cables of the unit shall be protected properly to prevent the insulation layer from damage due to sharp objects. The wire and cable shall be kept far away from the heat source and they shall not be bent or twisted

- Air filter

The accumulated dust of the unit strainer shall be inspected regularly (twice for each month as recommended). Users who have installed differential pressure detector shall clean or replace the filter in case the final resistance reaches the specified value and CARRIER suggests that the final resistance value shall be:

specification of filtration efficiency	suggested final resistance (Pa)
G3	100-200
G4	150-250
M5-M6	250-300

- Heat exchanger

The coil fin, copper pipes, etc. of the heat exchanger shall be free from scratch or flattening due to impact. The coil shall be kept clean and the coil fin can be brushed and washed with the nylon brush. It shall be cleaned with the vacuum cleaner before brushing. In case of the compressed air, the coil may be cleaned with the high-pressure air pipe or nozzle. Upon the cleaning of the coil, its external surface shall be free from dust and the heat transfer effect of the internal surface shall reach its initial updating and heat transfer capacity. Besides the fin cleaning, internal incrustation shall be washed and removed from the coil after the coil has been used for 2~3 years. The cold water and hot water for the unit coil shall be softened water.

- The belt tightness shall be readjusted after the unit has operated for one week and the regular inspection shall be conducted every three months of operation in future.
- The wiring pile head of the wire will be loosened after the unit operates for a certain time. It shall be inspected and tightened on the third day upon the first startup.
- Bearings for the fan and the motor shall be inspected regularly (three times per month as recommended). The seal ring of the motor bearing (for instance, V-seal ring) shall be inspected, and it shall be replaced timely if necessary; the erection joint shall be inspected to confirm whether it is loose; the bearing operation shall be inspected through monitoring the abnormal noise, vibration, oil consumption or with the bearing vibration measurement element, etc. In case of any abnormalities, the unit shall be shut down immediately, and causes shall be identified and eliminated timely. Heating shall be conducted or special tools shall be used for the assembly and disassembly of bearings and bearings shall not be knocked violently or moved.
- Servicing of fan bearing:
For fans with the oil nozzle, the lubricating oil of matching specification shall be filled into the bearing regularly.
In case that the users select the grease of the same designation for grease filling, they shall use the grease of the designation all the time.
- The validity of the lubricating grease depends on the grease type, revolving speed of bearings, bearing diameter and operating environment. Under normal conditions, the lubricating grease shall be replaced after the fan has operated for about 1,500 h; For fans in 24-hour operation, the lubricating grease shall be replaced upon 500~700-hour operation.
- Methods for lubricating oil filling: the bearing shall keep rotating during the grease filling, and in case that a layer of fresh grease overflow from the dust cover, the grease filling may be stopped and the wind wheel shall be rotated quickly manually to discharge excessive grease.

Maintenance And Service

The air conditioning unit is an equipment and users are suggested to record the daily operation data of the equipment and to conduct regular maintenance and service.

1. The following inspections shall be conducted properly before the use of the equipment:

- ◆ Shall be inspected to ensure that the wiring is correct and that there are no abnormalities on the rotation of the fan as per the operation and maintenance manual
- ◆ Shall be conducted to ensure that all the power supply lines and control lines are connected correctly, and that the wiring adheres to the given wiring diagram. Reliability checks on grounding have to be conducted, and all the connection terminals are to be checked and confirmed secured.
- ◆ The inspection shall be conducted to confirm whether all power supply lines and control lines are connected in position and whether the wiring is correct according to the wiring diagram, whether the grounding is reliable and whether all connection terminals are secure.

2. Daily maintenance during the equipment use:

Unit maintenance contents	Standard service cycle			Remarks
	Monthly	Quarterly	Half-yearly	
1. The inspection shall be inspected to confirm whether the power line (from the distribution cabinet to the unit) is loose or damaged.			★	
2. The inspection shall be conducted to confirm whether the condensate discharge is normal.		★	●	Is the installation conducted according to the pipe connection diagram? Is it dirty or blocked? Is the drainage smooth? Is there any overflow, etc. due to this?
3. The inspection shall be conducted to confirm whether there is abnormal noise during the operation of the unit.	★		●	For instance, sharp metal friction sound, whistlers, obvious clash or resonance, significant electromagnetic noise (disgusting) and other abnormal noise.
4. The inspection shall be conducted to confirm whether it is necessary to clean the air side of heat exchanger (surface dust, sundries, etc.)		★	●	Spaces among fins are full of dust and there are sundries attached on the inlet side of the coil, etc.
5. The inspection shall be conducted to confirm whether the air strainer is dirty or blocked and whether it is necessary to clean or replace the strainer.	★	●		The differential pressure alarm value and the scale value in the differential pressure gauge reach the final resistance value, etc.

3. We recommend the following maintenance and service methods for the equipment which is not used for a long time

- ◆ In case that the unit does not operate for a long time or does not operate in winter, the power must be turned off and the water shall be discharged from the water system and the steam coil of the unit.
- ◆ If necessary, the maintenance and service may be conducted according to the pre-use maintenance and service methods of the equipment.

★ Note

1. User service: mandatory inspection - recommended inspection - ★
2. Vulnerable parts required for the service shall be purchased from CARRIER.
3. The service methods apply to the cycle during normal use and the arrangement shall be made based on actual conditions in case of use in bad conditions.

Note



Carrier improves the world around us; Carrier improves people's lives; our products and services improve building performance; our culture of improvement will not allow us to rest when it comes to the environment.

