



39CQ Air Handling Unit

Air flow: 2000~130000m³/h





In 1998, Time magazine named Dr. Carrier one of its 20 most influential builders and titans of the 20th century.

Carrier® is a leading global provider of innovative HVAC, refrigeration, fire, security and building automation technologies. Supported by the iconic Carrier name, the company's portfolio includes industry-leading brands such as Carrier, Kidde, Edwards, LenelS2 and Automated Logic. Carrier's businesses enable modern life, delivering efficiency, safety, security, comfort, productivity and sustainability across a wide

range of residential, commercial and industrial applications.



Identification & Dimension

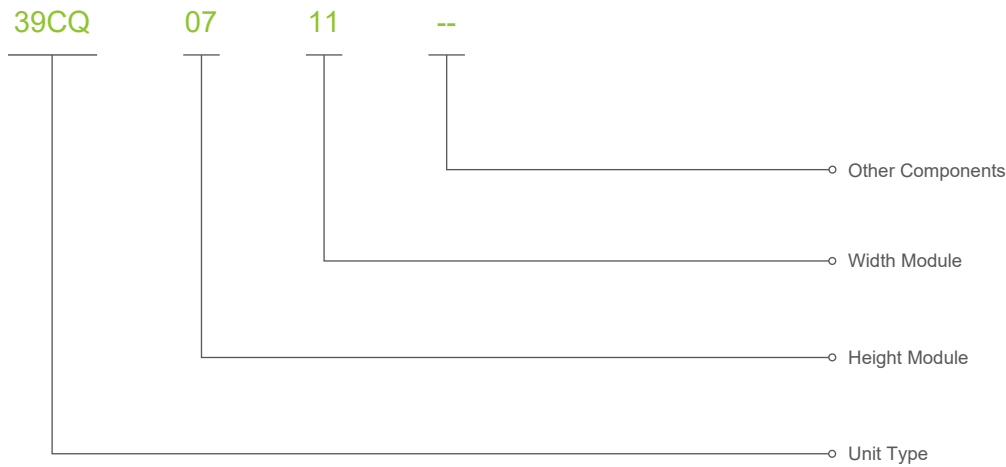

General rule of the height, width and length of a section or unit can be determined with the module concept:

A. 39CQ 0608~2735

(1) Unit Height = Height Module×100+90+80(base)

(2) Unit Width = Width Module×100+90

Example: 39CQ 0711

07 Height Module

Unit Height: $7 \times 100 + 90 + 80$ (base) = 870mm

11 Width Module

Unit Width: $11 \times 100 + 90 = 1190$ mm

B. 39CQ 3035~3843

Example: 39CQ3035

30 Height Module

Unit Height: $30 \times 100 + 90 + 100$ (base) = 3190mm

35 Width Module

Unit Module: $35 \times 100 + 90 = 3590$ mm

Note: 39CQ 0608-2735 can choose 80mm/100mm unit base height and 39CQ 3035-3843 can choose 100m/200mm unit base height in AHU software.

Unit orientation

Unit Orientation is determined by the location of the inlet and outlet pipes of the coil and the access panel while facing unit in the direction of air flow.

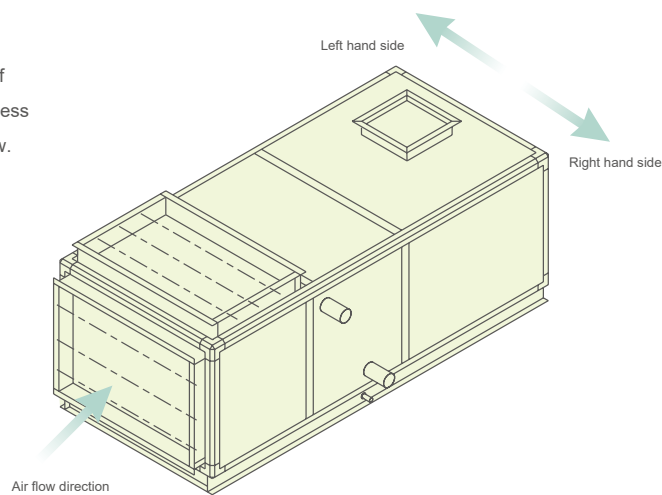

Air volume

39CQ: 2000~130000m³/h

Superior casing performance

T2/TB2/L1(M)/D1(M)/F9(M)(per EN1886 standard)

Excellent airtightness

The casing is made up of panels, frame and sealing strips. New casing structure of the unit avoids that any of the interior support member is exposed and ensures smooth internal surface, easy for cleaning and maintenance. New type of sealing strips between the frame and the panels, and careful sealing design to all access panels and locations passing-through pipes ensure excellent air tightness of the units.

Thermal bridge free

Carrier unique frame design enables pentapost and interpost covered by panel to prevent exposing in treated air, so the thermal bridge at posts is avoided. Each junction is subjected to special heat insulation treatment to prevent the thermal bridge effect. New design of screw also prevents the occurring of thermal bridge at screws, contributes to better casing performance.

Optimal thermal insulation

The middle layer of the unit panels is a 50mm thick PU foam with light weight, good rigidity, and thermal conductivity. Moreover, special insulation treatment is conducted at the inner parts of the frame and the middle frame strips to eliminate thermal transmission through the casing.

Access and serviceability design

Integrated control system

Factory assemble integrated control system with touch screen displayer saves installation and maintenance cost and ensures optimal operation.

Modular design convenient to select

The width, height and length of the unit are proportionally increased with 100mm as module. Each air volume corresponds with a certain unit type. Standard modular products make modeling and manufacturing faster and more convenient.

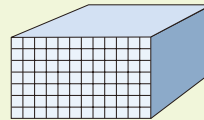

Double skin panel construction

Pre-painted panel as standard configuration of external panel, high durability (HDP) painted panel can be optional, ensure good rust preventive performance. Galvanized steel is standard for interior panel, and stainless steel sheet is also available.

Unit base

Each section has a base, which enhances the strength of the whole unit, reduces vibration, and make it easy to transport and assemble.

Easy maintenance

All basic component parts are standard and interchangeable with competitive prices. The unit is designed to have removable panels on its one side, and the access panels are arranged in the necessary components, providing convenience for repair and maintenance of the fan, coil and filter. The coil is installed on the guide rail inside the drain pan, enabling easy maintenance, cleaning and removal.

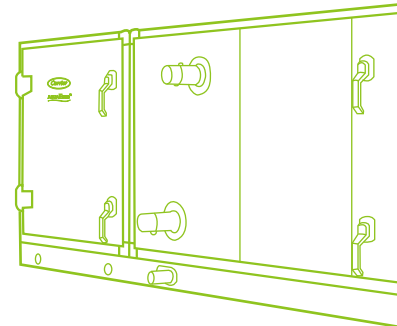

Various filters available to meet different needs

A complete line of filters is available, the levels of filters are ranging from primary filters (Panel type, filter class up to G4), to medium filters (Bag type, filter class up to F9), and to high filters (filter class up to H13). Some special filters such as activated-carbon filters, cartridge filters and electronstatic filters can also be provided.

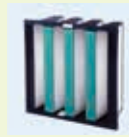

High efficiency filter



Bag filter



Panel filter

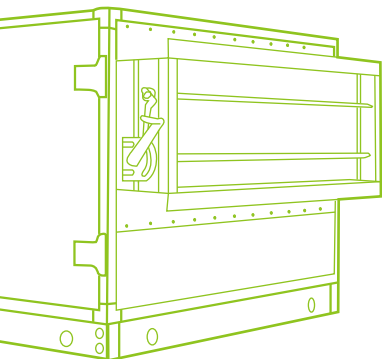

Flexible application

Optimized design, high efficiency and vibration-free operation

The fan impeller and pulley are statically and dynamically balanced, and the whole fan is calibrated through the operational vibration testing, making the fan to operate stably and smoothly. With the fan and motor assembly mounted on a common base with shock absorber and the fan outlet isolated from the casing by a flexible connection and completely separated from moving parts, the vibration is effectively isolated. Moreover, the forward or backward impeller may be selected according to the air pressure and volume.

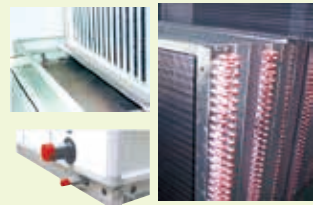

Hot and cold water coils designed according to international standard

Fins are the "dual sine-wave" form and mechanically bonded with copper tubes, realizing excellent heat transfer efficiency. Hydrophilic aluminum foils may also be utilized to achieve better heat transfer performance. The standard coil header is constructed of steel and can also be customized with lopper.



Headers have drain and vent connections, so coil is drainable and has non air trapping circuits. The water in the coil must be discharged in winter to avoid the frost crack of the coil.

If the coil face air velocity is higher than 2.5m/s, a drift eliminator can be installed on the back of the coil to effectively isolate moisture in air.

Corrugated damper flexible to adjust

With manual or electric mode available, the corrugated linkage damper can be opened flexibly, and can also add an electric controller as required.

Various heat recovery options

To improve indoor air quality is generally accomplished by introducing ventilation from outdoors. The air must be conditioned to match the indoor space. Carrier energy saving solution offer options for energy-recovery wheels, air-to-air heat exchangers, heat pipes, or coil-run-around loops. These proven technologies economically transfer energy between the exhaust-air and fresh-air paths, reducing the cost of conditioning the fresh air.



Heat wheels



Heat plate

Air Filtration and Purification Solutions

80%~90% of the urban population spend their time indoors ⁽¹⁾, so the quality of indoor air is crucial to human health. While designing air conditioning unit and system, Carrier always pays attention to indoor air quality (IAQ), and draws on filtration and purification technology to provide the public with a variety of scientific and effective solutions.

Solution 1: UV Lamp

The UV lamp can be selected in the AHU design software to be installed in the mixing section or empty section of the unit by factory. It does not take up the length of AHU unit and saves unit floor area.

- Carrier UV lamp features
 - 253.7nm UV lamp, not generate ozone
 - The reflector board enhances the radiation intensity and avoids direct exposure to human body
 - Plug-in type for easy installation
 - External wiring box with 220V AC standard power supply for easy wiring



UV Lamp

Solution 2: Nano Photocatalytic Module

Photocatalysis is a technology that utilizes a new type of high-tech functional composite nano material. The nanometer photocatalyst is activated by ultraviolet irradiation, and the photocatalyst interacts with the surrounding water molecules and oxygen to form a highly active hydroxyl OH. These hydroxy-radical OH layers lock up various harmful components in the air, decompose their molecular structure, so as to play a role in air purification, deodorization and other purposes.

Photocatalyst is the general name of a type of semiconductor material with catalytic function, represented by titanium dioxide (TiO₂). It does not change under the light, but can promote chemical reactions.

- Nano photocatalytic module can be selected in the AHU selection software,
 - Full-spread allocation to get large purification area
 - Modular design with reasonable configuration based on unit inner space
 - Plug-in type for easy installation
 - External control box, 220VAC standard power supply for easy wiring

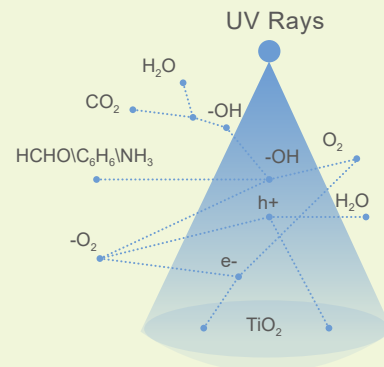

Nano photocatalytic module

(1) reference: <http://thecogfxstudy.com>, <http://thehealthfxstudy.com>

Solution 3: Electrostatic Filter

- High-voltage electrostatic filter can produce an electric field of about 6000 volts in the space, and when the particles in the air are ionized through the electric field, they are adsorbed on the dust collection board to achieve the role of air filtration and dust removal.
- Two kinds of high-voltage electrostatic filter, honeycomb and plate type, are available in Carrier AHU selection software, can flexibly meet with customer needs.

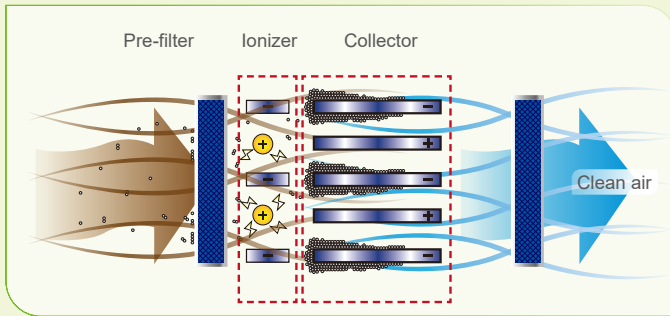

Honey type



Plate type

- Electronic static precipitator coupled catalyst (ESPCC) module is also available in AHU selection software. Along the airflow direction, electronic static precipitator coupled catalyst is composed of pre-filter, electrostatic module and catalytic module. It can generate a high-voltage electric field of about 8000 volts in the space, catalyze and decompose the ozone through the catalytic plate after the air is ionized, absorbed, and purified, so that the ozone can be reduced to a lower concentration. At the same time, the module is easy for maintenance and can be cleaned regularly.

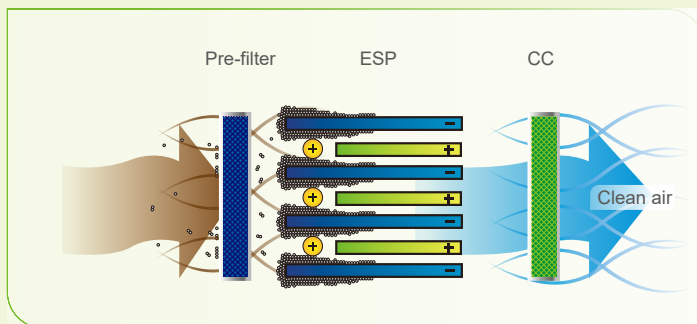

ESPCC module

Solution 4: Activated Carbon Filter

- Activated carbon adsorption technology is widely used to purify indoor polluted gases, which is mainly divided into two categories: physical adsorption and chemisorption. Physical adsorption is mainly for macromolecular organic gases (such as TVOC), through the adsorption of activated carbon's own micropore structure. Chemisorption is mainly for some small molecules of gaseous pollutants, such as formaldehyde, hydrogen sulfide, etc., and activated carbon is chemically reacted with it after processing to achieve the adsorption effect.
- Carrier can offer different types of activated carbon filters such as Plate type, Box type, V-type and Cylinder.



Plate / Box / V type

With use of chemical fiber and activated carbon composite filter media, plate/box/V type carbon filter is compact and lightweight, easy to install in tight space with needs of odor pollutants removal.



Cylinder

Different filter materials can be filled in the cylinder filter to achieve the purpose of removing different gases, mainly used in AHU fresh air system or exhaust gas purification equipment.

Solution 5: Medium Efficiency Filter and High Efficiency Filter

- According to China's filter standards GB/T14295-2019 and GB/T13554-2020, the medium efficiency filter is defined as a filter with a counting efficiency of 20% or more for the particle size of $\geq 0.5\mu\text{m}$ under rated air volume. It is required that the filtration efficiency of the high efficiency filter is no less than 99.95% after electrostatic charge and discharge. Therefore, both these two types of filters have a good purification effect on PM 2.5.
- In order to show air filtration more intuitively, Carrier re-calibrate Pre-filter and Medium efficiency filter with reference to ISO16890 filter standard, which can display the filtration effect of different levels of filters on three sizes of particles, PM1, PM2.5 and PM10. In Carrier AHU selection software, users can select the appropriate filter according to the needs of treating particle sizes.
- For the comparison between ISO16890 and EN779 Efficiency classification ⁽¹⁾ :
There is no direct conversion relationship between the two standards, and in order to facilitate comparison, the Eurovent Certita Certification recommends the following comparison table, showing a comparison of the test results according to EN 779 and ISO 16890. This comparison table is based on data from Eurovent Certita Certification testing on 91 filters.

EN 779 VS ISO16890

EN779:2012 Filter class	ISO16890 Measured Efficiency Range		
	ePM ₁	ePM _{2.5}	ePM ₁₀
M5	5% ~ 35%	10% ~ 45%	40% ~ 70%
M6	10% ~ 40%	20% ~ 50%	60% ~ 80%
F7	40% ~ 65%	65% ~ 75%	80% ~ 90%
F8	65% ~ 90%	75% ~ 95%	90% ~ 100%
F9	80% ~ 90%	85% ~ 95%	90% ~ 100%

(1) Reference: Eurovent 4/23-2017 《Selection of EN ISO 16890 rated air filter classes for general ventilation applications》

Common Applications of Direct Expansion Coil

The direct expansion air conditioning unit mainly consists of two main parts, indoor air handling unit and outdoor air-cooled condensing unit, without the need for water pumps and cooling towers. So it is easy for installation and also saves initial investment. As there are no indoor water pipes, it has no water leakage troubles and provide convenience for maintenance.

Direct expansion coils are installed in the indoor air handling unit for circulating heat transfer between refrigerant and air. They are currently widely used in the following situations.

Cooling application

- Direct expansion coil is used for cooling, replacing cold water coil.

Unit structure: mixing section+filter section+direct expansion coil section+fan section, and outdoor unit need be separately equipped.

Features: can operate independently without water sources, cooling effect is faster than cold water coil.

Applicable for occasions without water sources or requiring independent cold sources (such as hospital operating rooms)

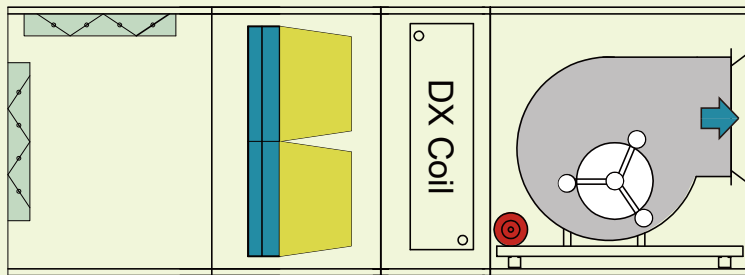

Dehumidification application

- Direct expansion coil is used for pre-cooling with deep dehumidification and simultaneously utilize condensation heat for reheating to achieve energy recovery.

Unit structure: mixing section+filter section+direct expansion coil section+cold water coil section+condensation reheat section+fan section, outdoor unit or cooling tower need be separately equipped.

Features: better dehumidification effect than cold water system; using condensation heat for reheating is more economical than traditional electric heating or hot water coil, and can achieve more accurate temperature and humidity control.

Applicable for occasions with certain requirements on humidity control (such as hospitals, subway stations, industrial application).

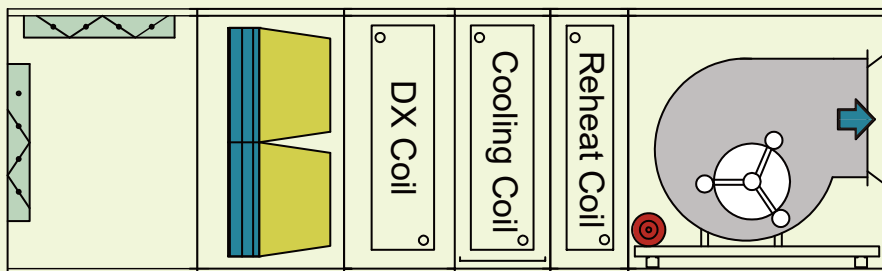

Integrated control system

39CQ air handling units, optional Carrier integrated control system, this new control system adopts advanced control and management system, and its control scheme can be optimized for different application requirements. Touch screen graphical display, more user friendly. Factory-mounted integrated controls saves installation and maintenance cost and ensures optimal operation.

Major control functions

- ✦ The unit is available with both stand-alone control or network control (can support BACnet Protocol)
- ✦ Standard control system includes the following functions:
 - Variable air flow control (standard with inverter)
 - CO2 demand control
 - Supply air temperature control by adjusting water valve
 - Humidifier On/Off control in winter
 - Filter alarm
 - Fan and outside air damper interlocking
- ✦ User-friendly control interface makes field commissioning and operation easy.
- ✦ AHU controller, temperature/humidity sensors, CO₂ sensor and pressure sensor
 - are factory mounted, which prevents possible damage during field installation.
- ✦ Major control component include:
 - SE6104 controller and auxiliary board
 - BACview6 control panel
 - Return air and outside air temperature sensors
 - Supplier air temperature and humidity sensors
 - CO2 sensor
 - Filter differential pressure switch
 - Inverter
 - Motorized proportional control valves
 - Motorized proportional control dampers
 - Options: anti-freeze switch, static pressure sensor, indoor temperature and humidity sensor.



Control diagram

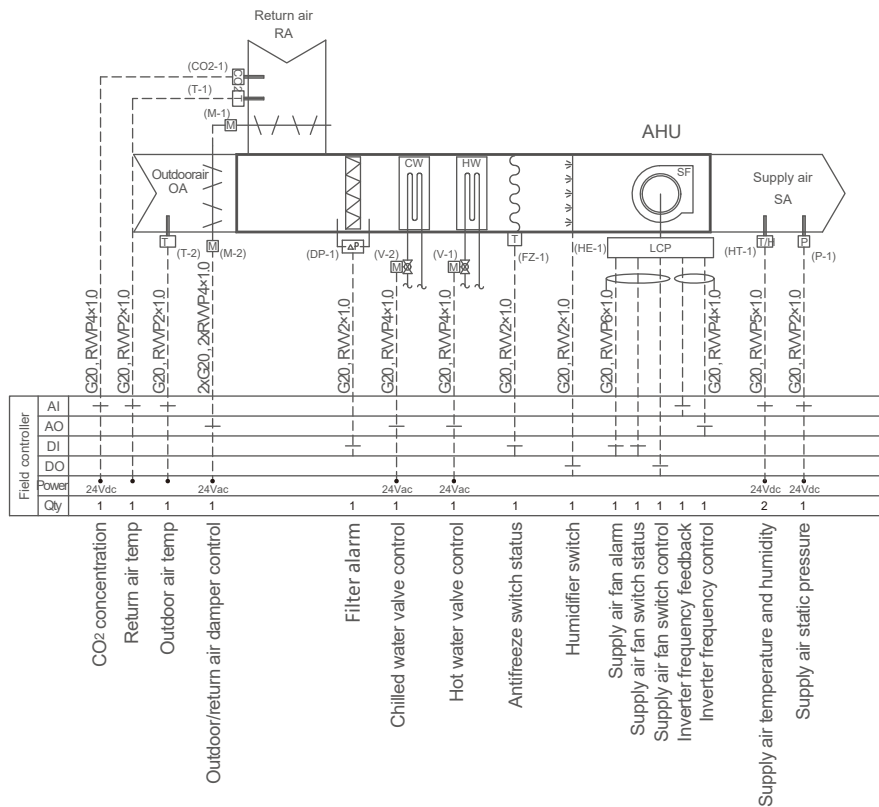

Quick selection

Model	Rating air volume m ³ /h	Coil face Area (m ²)	Air Volume (m ³ /h)			Inside Dimension of Damper mm*mm	Unit Dimension (mm)	
			Face Velocity				Height	Width
			2.25m/s	2.5m/s	2.75m/s			
39CQ0608	2000	0.23	1863	2070	2277	748*548	690	890
39CQ0609	3000	0.32	2592	2880	3168	848*548	690	990
39CQ0711	4000	0.46	3726	4140	4554	1048*448	790	1190
39CQ0811	5000	0.57	4617	5130	5643	1048*448	890	1190
39CQ0912	6000	0.69	5589	6210	6831	1148*448	990	1290
39CQ0913	7000	0.76	6156	6840	7524	1248*548	990	1390
39CQ0914	8000	0.84	6804	7560	8316	1348*548	990	1490
39CQ1015	10000	1.06	8586	9540	10494	1448*548	1090	1590
39CQ1117	12000	1.31	10611	11790	12969	1648*548	1190	1790
39CQ1317	15000	1.68	13608	15120	16632	1648*548	1390	1790
39CQ1418	18000	1.90	15390	17100	18810	1748*748	1490	1890
39CQ1420	20000	2.14	17334	19260	21186	1948*748	1490	2090
39CQ1621	25000	2.62	21222	23580	25938	2048*748	1690	2190
39CQ1822	30000	3.26	26406	29340	32274	2148*848	1890	2290
39CQ1825	32000	3.75	30375	33750	37125	2448*848	1890	2590
39CQ2025	35000	4.04	32724	36360	39996	2448*848	2090	2590
39CQ2125	40000	4.33	35073	38970	42867	2448*1048	2190	2590
39CQ2226	45000	4.82	39042	43380	47718	2548*1048	2290	2690
39CQ2328	50000	5.39	43659	48510	53361	2748*1048	2390	2890
39CQ2330	55000	5.81	47061	52290	57519	2948*1048	2390	3090
39CQ2333	60000	6.44	52164	57960	63756	3248*1048	2390	3390
39CQ2435	65000	7.22	58482	64980	71478	3448*1148	2490	3590
39CQ2635	70000	7.84	63504	70560	77616	3448*1248	2690	3590
39CQ2735	75000	8.26	66906	74340	81774	3448*1248	2790	3590
39CQ3035	80000	9.08	73553	81730	89897	3448*1248	3090	3590
39CQ3335	90000	10.11	81911	91020	100113	3448*1448	3390	3590
39CQ3438	100000	11.27	91298	101450	111586	3748*1448	3490	3890
39CQ3638	110000	12.17	98601	109560	120513	3748*1448	3690	3890
39CQ3841	120000	13.69	110894	123220	135537	4048*1748	3890	4190
39CQ3843	130000	14.40	116655	129620	142578	4248*1748	3890	4390

Note: 1. The unit height does not included the damper on the top and the base of 80mm(0608-2735)/100mm(3035~3843).

2. Above table is just for your reference. Please refer Carrier AHU selection software for detail information.

Software

Computer Selection

Our company provides the double-quick and accurate computer selection. We will get the reasonable and economic unit by working out the optimal function configuration to meet the customer's requirement.

Functions & Features

- 🍃 Project Management
- 🍃 Modular Designer
- 🍃 Free Section Combining
- 🍃 Section & Option Configuration
- 🍃 Shipping Configuration
- 🍃 Performance Calculation
- 🍃 Quotation
- 🍃 Drawings & Tech Specification
- 🍃 Multilingual & Friendly Interface





















Electric heater selection

No.	Unit Model	Face Area	1 Row Heater	2 Row Heater	3Row Heater
	Unit Size	(m ²)	Power range (kW)	Power range (kW)	Power range (kW)
1	39CQ0608	0.21	< 4	4~8	8~12
2	39CQ0609	0.25	< 5	5~10	10~15
3	39CQ0711	0.42	< 7	7~14	14~21
4	39CQ0811	0.49	< 11	11~22	22~33
5	39CQ0912	0.65	< 13	13~26	26~39
6	39CQ0913	0.72	< 15	15~30	30~45
7	39CQ0914	0.80	< 17	17~34	34~51
8	39CQ1015	0.99	< 24	24~48	48~72
9	39CQ1117	1.29	< 28	28~56	56~84
10	39CQ1317	1.56	< 35	35~70	70~105
11	39CQ1418	1.83	< 38	38~76	76~114
12	39CQ1420	2.08	< 43	43~86	86~129
13	39CQ1621	2.55	< 45	45~90	90~135
14	39CQ1822	3.07	< 58	58~116	116~174
15	39CQ1825	3.56	< 70	70~140	140~210
16	39CQ2025	4.00	< 80	80~160	160~240
17	39CQ2125	4.21	< 90	90~180	180~270
18	39CQ2226	4.63	< 95	95~190	190~285
19	39CQ2328	5.29	< 100	100~200	200~300
20	39CQ2330	5.72	< 105	105~210	210~315
21	39CQ2333	6.36	< 120	120~240	240~360
22	39CQ2435	7.11	< 125	125~250	250~375
23	39CQ2635	7.74	< 140	140~280	280~420
24	39CQ2735	8.06	< 140	140~280	280~420
25	39CQ3035	7.85	< 150	150~300	300~450
26	39CQ3335	8.68	< 165	165~330	330~495
27	39CQ3438	10.38	< 180	180~360	360~540
28	39CQ3638	10.38	< 180	180~360	360~540
29	39CQ3841	11.82	< 210	210~420	420~630
30	39CQ3843	12.73	< 210	210~420	420~630

Note: 1. Star connection is used in the wiring of electric heaters. Multi-group control is available, in which the capacity for each group is generally 30kW or less. The power supply is 3-phase 380V.
 2. Minimum air velocity is 2m/s.
 3. 3M module holds maximum of 3 row heater.
 4. Capacity exceeding 3 row should choose two separated heaters in 6M module section.

Standard components (0608~2735)

No.	Unit Section	Diagram	Section Length (M: Module)	Remark
1	Return/Mixing Chamber		(0608~0912) 5M (0913~1317) 6M (1418~1621) 8M (1822~2025) 9M (2125~2333) 11M (2435) 12M (2635~3035) 13M (3335~3638) 15M (3841~3843) 18M	
2	Single Filter (panel/bag)		3/4/5/6/8/9M	Access section is recommended at upstream
3	Combined Filter		3/4/5/6/8/9M	Access section is recommended at upstream
4	Cooling Coil		(0609~2735) 5/6/7/8M (3035~3843) 6/7/8M	
5	Heating Coil		(0609~2735) 3/4/5/6/7M (3035~3843) 4/6/7M	May be installed together with the cooling coil if this cooling coil does not include a film humidifier and a drift eliminator
6	Steam Heating Coil		3M	
7	Electric Heating Coil		3M	
8	Steam Humidifier		6M	
9	Film Humidifier		0M	May be installed directly in the coils and drain pan, no additional space needed
10	Spray Humidifier		6M/8M	Could share the drift eliminator with cooling coil when it is installed next the coil
11	Fan		Refer to fan table	Four discharge configurations available
12	Combined Mixing Chamber		(0608~0912) 10M (0913~1825) 12M (2025~2333) 18M (2435~3335) 24M (3438~3638) 32M (3841~3843) 38M	
13	Attenuator		6M (1 Level) 12M (2 Level))	Access section is recommended at upstream
14	Supply Chamber		(0608~0912) 5M (0913~1317) 6M (1418~1621) 8M (1822~2025) 9M (2125~2333) 11M (2435) 12M (2635~3035) 13M (3335~3638) 15M (3841~3843) 18M	Supply damper may be installed in either a vertical or a horizontal position
15	Plenum/Access		≥ 1M	
16	High Efficiency Filter		≥ 8M	
17	Energy Recovery		6M/9M (Heat wheel)	Module of plate exchanger depends on unit model
18	Electrode Humidifier		6M	
19	Electrostatic Filter		4M	

1/2" Coil connection (0608~3843)

Cooling coil 0608~1825

Unit Size	A	B	F	D						E						ØC
				3R	4R	5R	6R	7R	8R	3R	4R	5R	6R	7R	8R	
0608	790	357	232	105	91	77	63	102	84	160	174	187	201	212	226	1-1/2" MPT
0609	790	421	232	105	91	77	63	102	84	160	174	187	201	212	226	1-1/2" MPT
0711	890	472	238	105	91	77	70	102	84	175	174	187	194	212	226	2" MPT
0811	990	599	238	105	91	77	70	102	84	175	174	187	194	212	226	2" MPT
0912	1090	648	246	105	91	77	77	102	84	187	174	187	187	212	226	2-1/2" MPT
0913	1090	648	246	105	91	77	77	102	84	187	174	187	187	212	226	2-1/2" MPT
0914	1090	648	246	105	91	77	77	102	84	187	174	187	187	212	226	2-1/2" MPT
1015	1190	775	246	105	91	77	77	102	84	187	174	187	187	212	226	2-1/2" MPT
1117	1290	824	253	84	84	84	84	102	84	180	181	180	180	212	226	3" MPT
1317	1490	1078	253	84	84	84	84	102	84	180	181	180	180	212	226	3" MPT
1418	1590	1142	253	84	84	84	84	102	84	180	181	180	180	212	226	3" MPT
1420	1600	1142	253	84	84	84	84	102	84	180	181	180	180	212	226	3" MPT
1621	1790	1332	253	84	84	84	84	102	84	180	181	180	180	212	226	3" MPT
1822	1990	1586	253	84	84	84	84	102	84	180	181	180	180	212	226	3" MPT
1825	1990	1586	253	84	84	84	84	102	84	180	181	180	180	212	226	3" MPT

Heating coil 0608~1825

Unit Size	A	F	D		B		E		ØC
			1R	2R	1R	2R	1R	2R	
0608	790	232	62	61.75	341	357	131	131	1-1/2" MPT
0609	790	232	62	61.75	405	421	131	131	
0711	890	232	62	61.75	468	484	131	131	
0811	990	232	62	61.75	595	611	131	131	
0912	1090	232	62	61.75	659	675	131	131	
0913	1090	232	62	61.75	659	675	131	131	
0914	1090	232	62	61.75	659	675	131	131	
1015	1190	232	62	61.75	786	802	131	131	
1117	1290	232	62	61.75	849	865	131	131	
1317	1490	232	62	61.75	1103	1119	131	131	
1418	1590	232	62	61.75	1167	1183	131	131	
1420	1600	232	62	61.75	1167	1183	131	131	
1621	1790	232	62	61.75	1357	1373	131	131	
1822	1990	232	62	61.75	1611	1627	131	131	
1825	1990	232	62	61.75	1611	1627	131	131	

Note: The data in table are just for your reference

1/2" Cooling & heating coil dimension

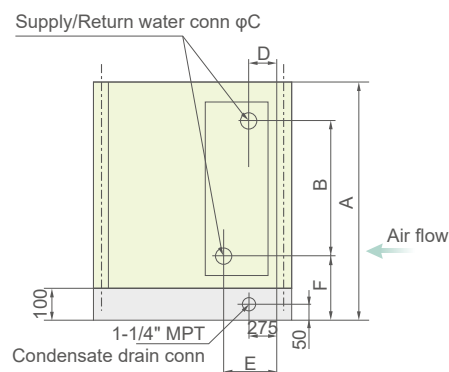

39CQ: 0608-1825

Note: 39CQ0608-1825 can choose 80mm or 100mm unit base height in AHU software.

1/2" Coil connection (0608~3843)

Cooling coil 2025~3843

Unit Size	A	B	F	G	D				E				ØC
					3R/4R/6R	5R	7R	8R	3R/4R/6R	5R	7R	8R	
2025	2190	950	257	694	109	84	102	88	206	230	212	226	3" MPT
2125	2290	1077	257	694	109	84	102	88	206	230	212	226	3" MPT
2226	2390	1204	257	694	109	84	102	88	206	230	212	226	3" MPT
2328	2490	1268	257	694	109	84	102	88	206	230	212	226	3" MPT
2330	2490	1268	257	694	109	84	102	88	206	230	212	226	3" MPT
2333	2490	1268	257	694	109	84	102	88	206	230	212	226	3" MPT
2435	2590	1395	257	694	84	84	84	84	204	204	204	204	4" MPT
2635	2790	1586	257	694	84	84	84	84	204	204	204	204	4" MPT
2735	2890	1713	257	694	84	84	84	84	204	204	204	204	4" MPT
3035	3190	1127	270	1127	116	116	116	116	254	254	254	254	4" MPT
3335	3490	1317.5	270	1254	116	116	116	116	254	254	254	254	4" MPT
3438	3590	1317.5	270	1317.5	116	116	116	116	254	254	254	254	4" MPT
3638	3790	1444.5	270	1444.5	116	116	116	116	254	254	254	254	4" MPT
3841	3990	1508	270	1508	116	116	116	116	254	254	254	254	4" MPT
3843	3990	1508	270	1508	116	116	116	116	254	254	254	254	4" MPT

Heating coil 2025~3843

Unit Size	A	F	B		D		E		G		H		ØC
			1R	2R	1R	2R	1R	2R	1R	2R	1R	2R	
2025	2190	232	976	992	62	61.75	131	131	723	729	62	56	1-1/2" MPT
2125	2290	232	1103	1119	62	61.75	131	131	723	729	62	56	
2226	2390	232	1230	1246	62	61.75	131	131	723	729	62	56	
2328	2490	232	1294	1309.5	62	61.75	131	131	723	729	62	56	
2330	2490	232	1294	1309.5	62	61.75	131	131	723	729	62	56	
2333	2490	232	1294	1309.5	62	61.75	131	131	723	729	62	56	
2435	2590	232	1421	1437	62	61.75	131	131	723	729	62	56	
2635	2790	232	1612	1628	62	61.75	131	131	723	729	62	56	
2735	2890	232	1739	1755	62	61.75	131	131	723	729	62	56	
3035	3190	232	1193	1193	62	62	131	131	1193	1193	244	244	
3335	3490	232	1383.5	1383.5	62	62	131	131	1320	1320	244	244	
3438	3590	232	1383.5	1383.5	62	62	131	131	1383.5	1383.5	244	244	
3638	3790	232	1510.5	1510.5	62	62	131	131	1510.5	1510.5	244	244	
3841	3990	232	1574	1574	62	62	131	131	1574	1574	244	244	
3843	3990	232	1574	1574	62	62	131	131	1574	1574	244	244	

Note: The data in table are just for your reference

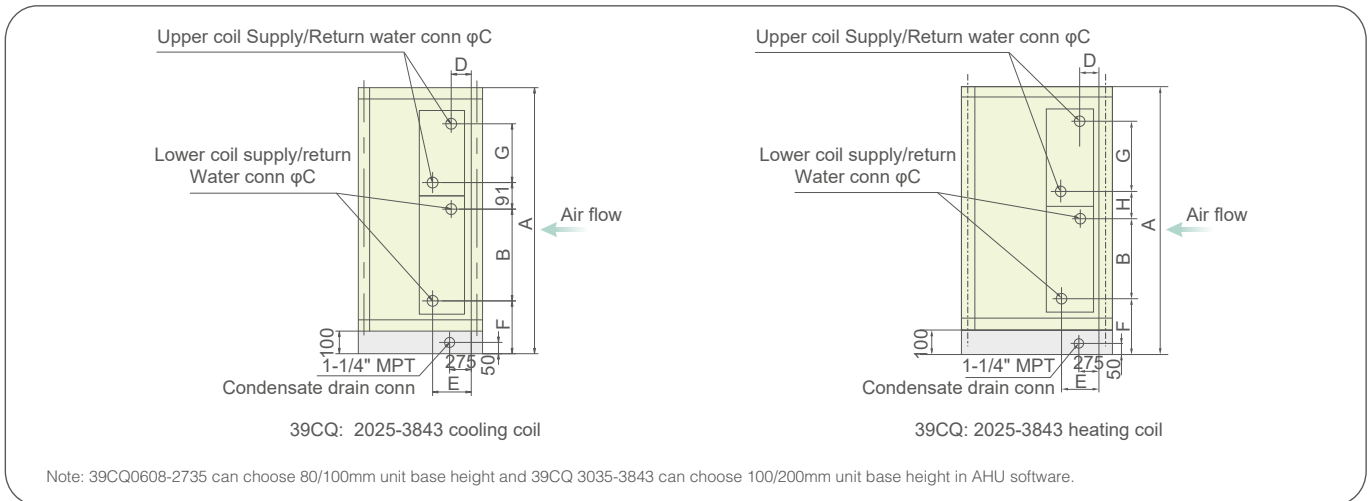

3/8" Coil connection (0608~1317)

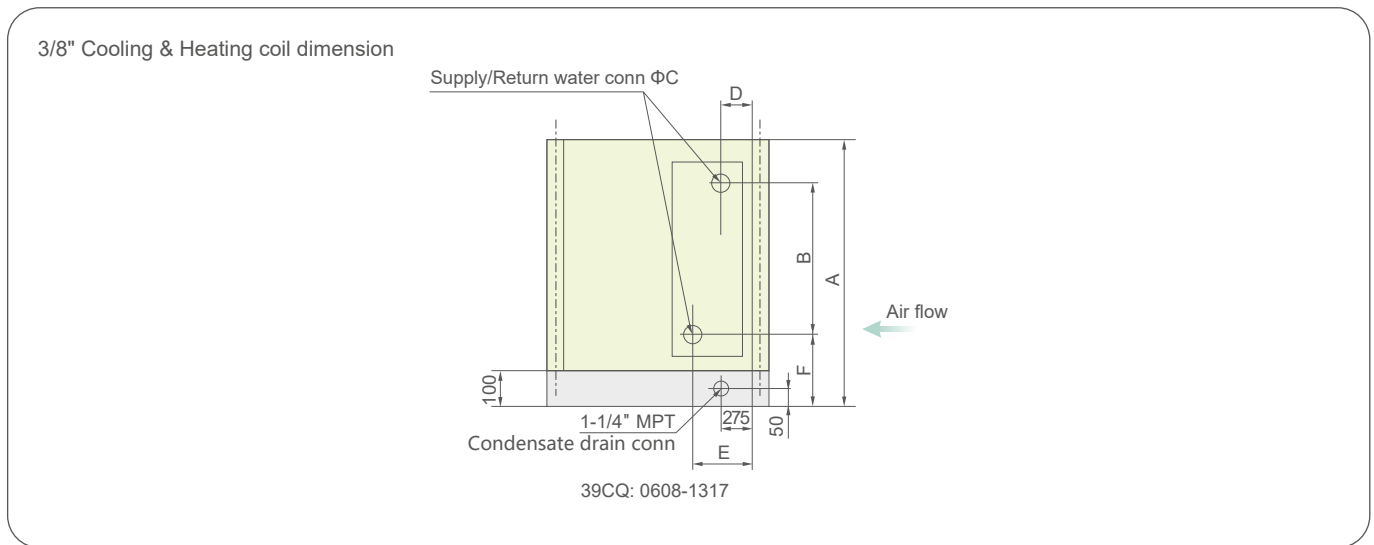

Cooling coil 0608~1317

Unti Size	A	F	B	D					E					ØC
				3R	4R/6R	5R	7R	8R	3R	4R/6R	5R	7R	8R	
0608	800	231	384	95	77	88	91	102	169	187	176	223	212	1-1/2" MPT
0609	800	231	435	95	77	88	91	102	169	187	176	223	212	1-1/2" MPT
0711	900	237	474	95	77	88	91	102	169	187	176	223	212	2" MPT
0811	1000	237	576	95	77	88	91	102	169	187	176	223	212	2" MPT
0912	1100	245	661	85	77	88	91	102	179	187	176	223	212	2-1/2" MPT
0913	1100	245	661	85	77	88	91	102	179	187	176	223	212	2-1/2" MPT
0914	1100	245	661	85	77	88	91	102	179	187	176	223	212	2-1/2" MPT
1015	1200	245	763	85	77	88	91	102	179	187	176	223	212	2-1/2" MPT
1117	1300	252	850	85	84	88	91	102	179	180	176	223	212	3" MPT
1317	1500	252	1054	85	84	88	91	102	179	180	176	223	212	3" MPT

Note: The data in table are just for your reference.

Heating coil 0608~1317

Unti Size	A	F	B		D	E	ØC
			1R	2R	1R/2R	1R/2R	
0608	800	231	372	385	62	131	1-1/2" MPT
0609	800	231	423	436	62	131	
0711	900	231	474	487	62	131	
0811	1000	231	575	588	62	131	
0912	1100	231	677	690	62	131	
0913	1100	231	677	690	62	131	
0914	1100	231	677	690	62	131	
1015	1200	231	778	791	62	131	
1117	1300	231	880	893	62	131	
1317	1500	231	1083	1096	62	131	

Note: The data in table are just for your reference.

Steam coil connection (0608~3843)

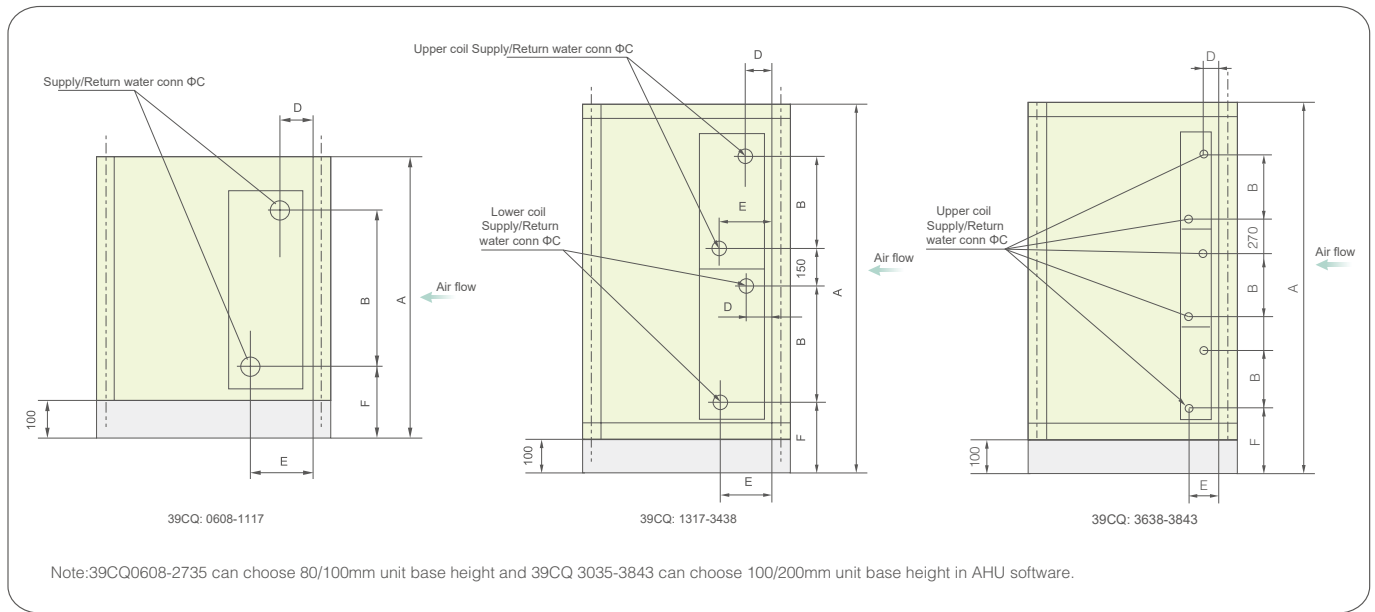

Unit Size	A	F	B	ØC	D	E
0608	790	243	347	2" MPT	80	150
0609	790	243	347	2" MPT	80	150
0711	890	243	418	2" MPT	80	150
0811	990	243	560	2" MPT	80	150
0912	1090	243	631	2" MPT	80	150
0913	1090	243	631	2" MPT	80	150
0914	1090	243	631	2" MPT	80	150
1015	1190	243	738	2" MPT	80	150
1117	1290	243	738	2" MPT	80	150

Note: The data in table are just for your reference.

Unit Size	A	F	B	ØC	D	E
1317	1490	243	489	2" MPT	80	150
1418	1590	243	520	2" MPT	80	150
1420	1590	243	520	2" MPT	80	150
1621	1790	243	631	2" MPT	80	150
1822	1990	243	738	2" MPT	80	150
1825	1990	243	738	2" MPT	80	150
2025	2190	243	844	2" MPT	80	150
2125	2290	243	844	2" MPT	80	150
2226	2390	243	844	2" MPT	80	150
2328	2490	243	884	2" MPT	80	150
2330	2490	243	884	2" MPT	80	150
2333	2490	243	884	2" MPT	80	150
2435	2590	243	924	2" MPT	80	150
2635	2790	243	1004	2" MPT	80	150
2735	2890	243	1084	2" MPT	80	150
3035	3190	243	1064	2" MPT	80	150
3335	3490	243	1224	2" MPT	80	150
3438	3590	243	1224	2" MPT	80	150
3638	3790	243	824	2" MPT	80	150
3841	3990	243	904	2" MPT	80	150
3843	3990	243	904	2" MPT	80	150

Note: The data in table are just for your reference.

Fan & Motor (0608~3843)

Unit Size	Fan Model	Max. Motor Power (kw)	Max.Motor Model
39CQ0608	FC160	1.5	Y90
	FC180		
39CQ0609	FC180	2.2	Y100
	FC200		
39CQ0711	FC200	3.7	Y112
	FC225		
39CQ0811	FC225	3.7	Y112
	FC/BC250		
39CQ0912	FC/BC250	5.5	Y132
	FC/BC280		
39CQ0913	FC/BC280	5.5	Y132
	FC/BC315		
39CQ0914	FC/BC315	7.5	Y132
	FC/BC355		
39CQ1015	FC/BC355	7.5	Y132
	FC/BC400		
39CQ1117	FC/BC400	11	Y160
	FC/BC450		
39CQ1317	FC/BC400	15	Y160
	FC/BC450		
39CQ1418	FC/BC450	15	Y160
	FC/BC500		
39CQ1420	FC/BC500	18.5	Y180
	FC/BC560		
39CQ1621	FC/BC560	18.5	Y180
	FC/BC630		
39CQ1822	FC/BC560	18.5	Y180
	FC/BC630		
39CQ1825	FC/BC630	30	Y200
	FC/BC710		
39CQ2025	FC/BC630	30	Y200
	FC/BC710		
39CQ2125	FC/BC710	30	Y200
	FC/BC800		
39CQ2226	FC/BC710	30	Y200
	FC/BC800		
39CQ2328	FC/BC800	37	Y225
	FC/BC900		
39CQ2330	FC/BC800	37	Y225
	FC/BC900		
39CQ2333	FC/BC800	45	Y225
	FC/BC900		
39CQ2435	FC/BC900	55	Y250
	FC/BC1000		
39CQ2735	FC/BC900	75	Y280
	FC/BC1000		
39CQ3035	FC/BC1000	110	Y315
	FC/BC1120		
39CQ3335	FC/BC1000	110	Y315
	FC/BC1120		
39CQ3438	FC/BC1120	110	Y315
	FC/BC1250		
39CQ3638	FC/BC1120	110	Y315
	FC/BC1250		
39CQ3841	FC/BC1250	110	Y315
	FC/BC1400		
39CQ3843	FC/BC1250	110	Y315
	FC/BC1400		

Note: Please refer to selection software for detailed fan section parameter.

Fan arrangement-horizontal unit

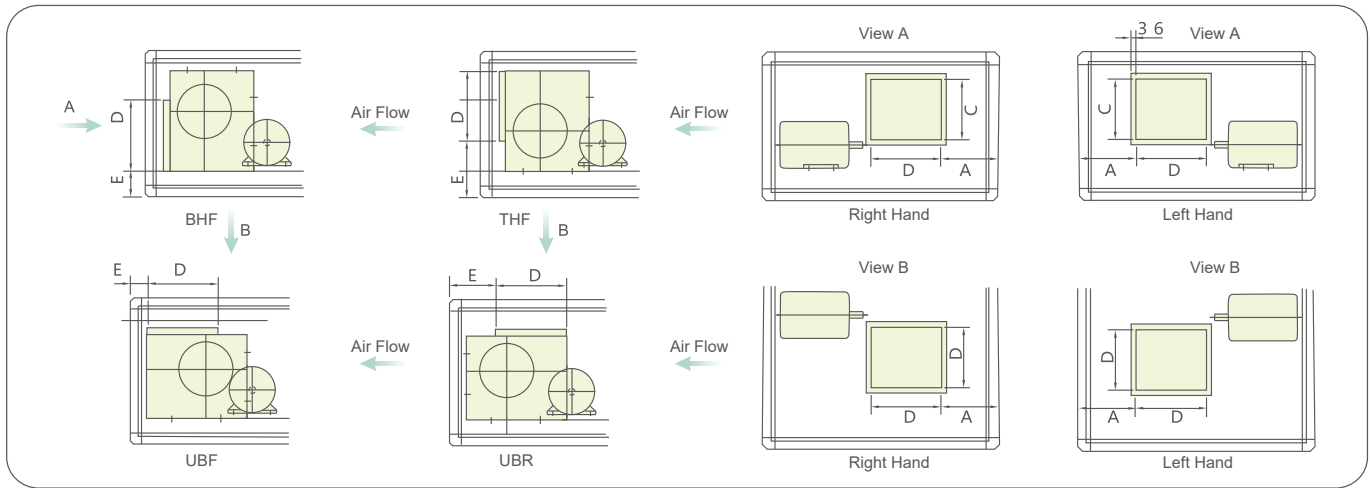

(mm)

Unit Size	Fan Model	A	D	E			
				THF	BHF	UBF	UBR
39CQ0608	FC160	224.0	205.0	285.5	163.0	224.0	192.0
	FC180	179.5	229.0	285.5	163.0	188.0	217.0
39CQ0609	FC180	291.0	229.0	285.5	163.0	188.0	217.0
	FC200	260.5	256.0	293.5	163.0	187.0	226.0
39CQ0711	FC200	360.5	256.0	293.5	163.0	187.0	226.0
	FC225	311.5	288.0	307.5	163.0	201.0	263.0
39CQ0811	FC225	311.5	288.0	307.5	163.0	201.0	263.0
	FC/BC250	311.5	322.0	319.0	163.0	176.0	252.0
39CQ0912	FC/BC250	361.5	322.0	319.0	163.0	176.0	252.0
	FC/BC280	335.5	361.0	336.0	163.0	175.0	301.0
39CQ0913	FC/BC280	385.5	361.0	336.0	163.0	175.0	301.0
	FC/BC315	342.5	404.0	355.0	163.0	170.0	288.0
39CQ0914	FC/BC315	392.5	404.0	355.0	163.0	170.0	288.0
	FC/BC355	395.5	453.0	380.0	188.0	170.0	310.0
39CQ1015	FC/BC355	445.5	453.0	380.0	188.0	170.0	310.0
	FC/BC400	394.5	507.0	408.0	188.0	170.0	340.0
39CQ1117	FC/BC400	494.5	507.0	408.0	188.0	170.0	340.0
	FC/BC450	434.5	569.0	437.0	188.0	170.0	368.0
39CQ1317	FC/BC400	494.5	507.0	408.0	188.0	170.0	340.0
	FC/BC450	389.5	569.0	437.0	188.0	170.0	368.0
39CQ1418	FC/BC450	439.5	569.0	437.0	188.0	170.0	368.0
	FC/BC500	420.5	638.0	458.0	188.0	170.0	390.0
39CQ1420	FC/BC500	520.5	638.0	458.0	188.0	170.0	390.0
	FC/BC560	511.5	715.0	549.0	248.0	170.0	421.0
39CQ1621	FC/BC560	511.5	715.0	549.0	248.0	170.0	421.0
	FC/BC630	425.5	801.0	591.0	248.0	170.0	464.0
39CQ1822	FC/BC560	611.5	715.0	549.0	248.0	170.0	421.0
	FC/BC630	525.5	801.0	591.0	248.0	170.0	464.0
39CQ1825	FC/BC630	720.5	801.0	591.0	248.0	170.0	464.0
	FC/BC710	623.5	898.0	639.0	248.0	170.0	511.0
39CQ2025	FC/BC630	720.5	801.0	591.0	248.0	170.0	464.0
	FC/BC710	623.5	898.0	639.0	248.0	170.0	511.0
39CQ2125	FC/BC710	573.5	898.0	639.0	248.0	170.0	511.0
	FC/BC800	513.5	1007.0	708.0	261.0	170.0	567.0
39CQ2226	FC/BC710	673.5	898.0	639.0	248.0	170.0	511.0
	FC/BC800	613.5	1007.0	708.0	261.0	170.0	567.0
39CQ2328	FC/BC800	663.5	1007.0	708.0	261.0	170.0	567.0
	FC/BC900	635.5	1130.0	765.0	261.0	170.0	624.0
39CQ2330	FC/BC800	815.0	1007.0	708.0	261.0	170.0	567.0
	FC/BC900	787.0	1130.0	765.0	261.0	170.0	624.0
39CQ2333	FC/BC800	963.5	1007.0	708.0	261.0	170.0	567.0
	FC/BC900	935.5	1130.0	765.0	261.0	170.0	624.0
39CQ2435	FC/BC900	1135.5	1130.0	765.0	261.0	170.0	624.0
	FC/BC1000	1035.5	1267.0	833.0	310.0	170.0	643.0
39CQ2635	FC/BC900	1135.5	1130.0	765.0	261.0	170.0	624.0
	FC/BC1000	1035.5	1267.0	833.0	310.0	170.0	643.0
39CQ2735	FC/BC900	1035.5	1130.0	765.0	261.0	170.0	624.0
	FC/BC1000	935.5	1267.0	833.0	310.0	170.0	643.0
39CQ3035	FC/BC1000	996.0	1267.0	812.0	291.0	185.0	708.0
	FC/BC1120	706.0	1422.0	980.0	434.0	230.0	882.0
39CQ3335	FC/BC1000	996.0	1267.0	812.0	291.0	185.0	708.0
	FC/BC1120	706.0	1422.0	980.0	434.0	230.0	882.0
39CQ3438	FC/BC1120	856.0	1422.0	980.0	434.0	230.0	882.0
	FC/BC1250	1038.0	1516.0	1137.0	459.0	230.0	1008.0
39CQ3638	FC/BC1120	856.0	1422.0	980.0	434.0	230.0	882.0
	FC/BC1250	1038.0	1516.0	1137.0	459.0	230.0	1008.0
39CQ3841	FC/BC1250	1343.0	1516.0	1137.0	459.0	230.0	1008.0
	FC/BC1400	1208.0	1795.0	1144.0	489.0	230.0	995.0
39CQ3843	FC/BC1250	1443.0	1516.0	1137.0	459.0	230.0	1008.0
	FC/BC1400	1308.0	1795.0	1144.0	489.0	230.0	995.0

Note: The length mentioned is internal dimensions of fan section.

Fan arrangement-vertical unit

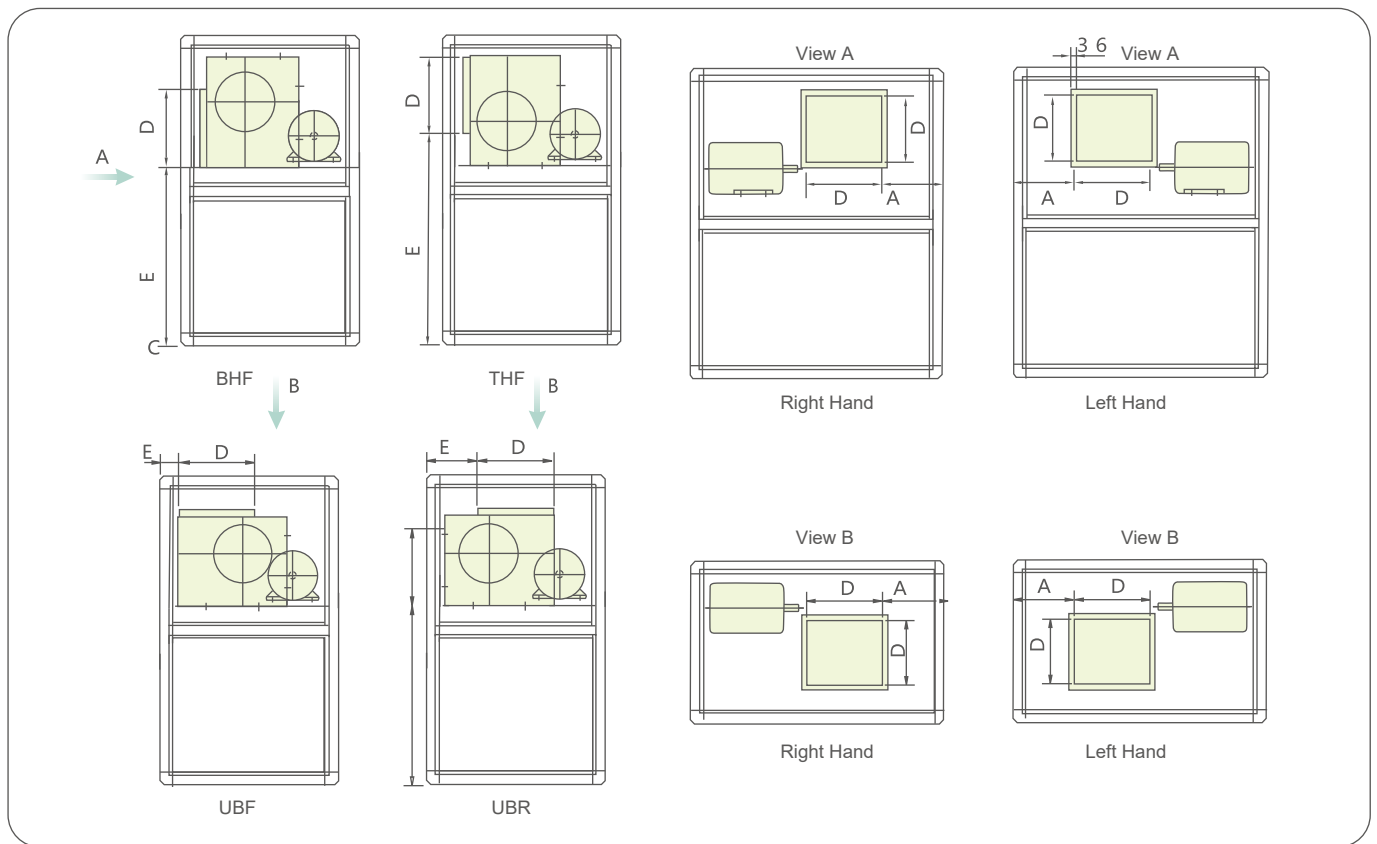

(mm)

Unit Size	Fan Model	A	D	E			
				THF	BHF	UBF	UBR
39CQ0608	FC160	224.0	205	985.5	863.0	170	192
	FC180	179.5	229	985.5	863.0	170	217
39CQ0609	FC180	291.0	229	985.5	863.0	170	217
	FC200	260.5	256	993.5	863.0	170	226
39CQ0711	FC200	360.5	256	1093.5	963.0	170	226
	FC225	311.5	288	1107.5	963.0	170	263
39CQ0811	FC225	311.5	288	1207.5	1063.0	170	263
	FC/BC250	311.5	322	1219.0	1063.0	170	252
39CQ0912	FC/BC250	361.5	322	1319.0	1163.0	170	252
	FC/BC280	335.5	361	1336.0	1163.0	170	301
39CQ0913	FC/BC280	385.5	361	1336.0	1163.0	170	301
	FC/BC315	342.5	404	1355.0	1163.0	170	288
39CQ0914	FC/BC315	392.5	404	1355.0	1163.0	170	288
	FC/BC355	395.5	453	1380.0	1188.0	170	310
39CQ1015	FC/BC355	445.5	453	1480.0	1288.0	170	310
	FC/BC400	394.5	507	1508.0	1288.0	170	340
39CQ1117	FC/BC400	494.5	507	1608.0	1388.0	170	340
	FC/BC450	434.5	569	1637.0	1388.0	170	368
39CQ1317	FC/BC400	494.5	507	1808.0	1588.0	170	340
	FC/BC450	389.5	569	1837.0	1588.0	170	368
39CQ1418	FC/BC450	439.5	569	1937.0	1688.0	170	368
	FC/BC500	420.5	638	1958.0	1688.0	170	390
39CQ1420	FC/BC500	520.5	638	1958.0	1688.0	170	390
	FC/BC560	511.5	715	2049.0	1748.0	170	421
39CQ1621	FC/BC560	511.5	715	2249.0	1948.0	170	421
	FC/BC630	425.5	801	2291.0	1948.0	170	464

Note: The data in table are just for your reference.

Ordering Information

1. Unit Direction: Along the airflow direction, left unit refers to units with water inlet and outlet of the coils and the access door on the left side, vice versa.
2. If units installed at outdoors or in corrosive environment, shall consult factory before ordering so as to ensure unit meet with application requirements.
3. Requirements of the unit basement: The length and width of the unit basement should be designed according to the unit, and the basement should be horizontally flat and higher than the ground for ease of installation of the condensate trap.

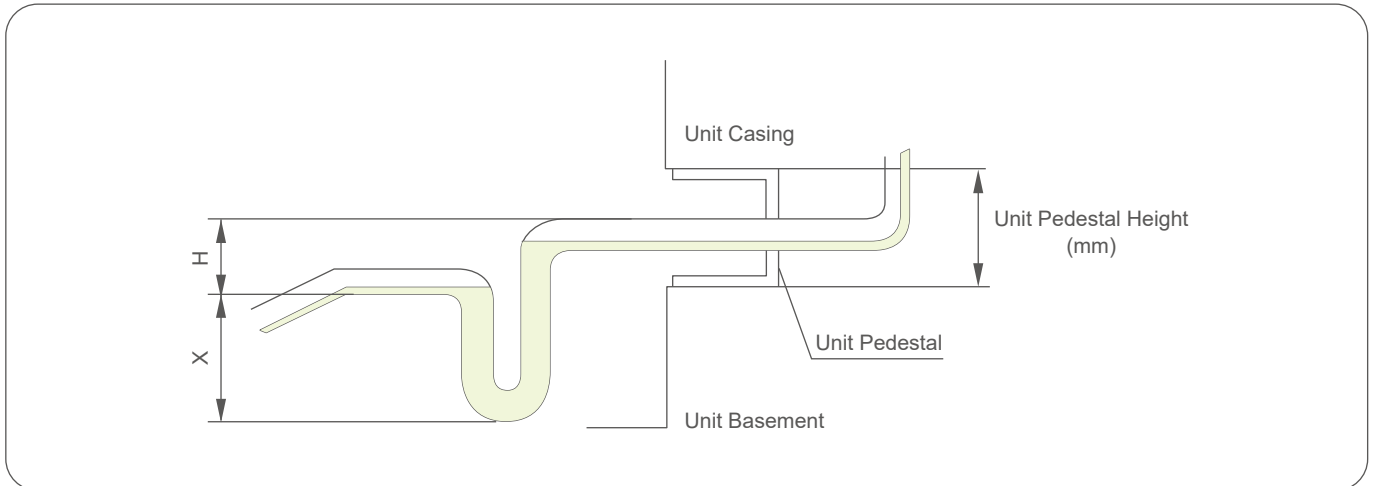

- Calculated Value: $H = \text{Negative pressure at the drain hole of the condensate plate Pa} / 10(\text{mm})$, $X > 1/2H$

- Empirical Value: when negative pressure $< 1,000 \text{ Pa}$, $H = 100\text{mm}$, $X = 70\text{mm}$

4. Notice when connecting the coil: The designed working pressure of both cooling and heating coil is 1.6mPa.
5. For fresh air units, when the temperature drops below 2°C , preheating devices should be required to prevent frost cracking of the coils inside the units.
6. The supply air temperature of the unit should not be higher than 80°C (when heating), requests as such shall be brought forward when ordering, so that high temperature bearings and motors could be adopted.
7. The unit outlet and duct should be connected with flexible connection.
8. Residual water should be drained of the coil if the temperature falls below the freezing point when the unit is shut down. Put antifreeze in the coil in case there's still residual water.
9. For electric heating,
 - 1) Electrical components and cable configuration shall be wires according to the power of electric heater.
 - 2) Wiring shall be carried out in line with the electric heater wiring diagram.
 - 3) The temperature relay signal of the electric heater shall be sent to the electric heating controller, to assure automatic power off when the temperature is too high in the unit.
 - 4) The controller of electric heater shall interlock control fan and electric heater, to keep the electric heater module powered off when the fan stops.
10. PTC thermistor has been installed in fan motor, should connected with protective relay, to achieve motor overheating protection function. If customer need more information about how to choose protective relay, please contact THC for technical support.



Carrier improves the world around us; Carrier improves people's lives; our products and services improve building performance; our culture of improvement will not allow us to rest when it comes to the environment.



www.carrier.com

The Manufacturer reserves the right to change any product specifications without prior notices
© All Rights Reserved Carrier

Version:	CAT_39CQ_E-202403_07
Supersede:	CAT_39CQ_E-202101_06
Effective Date:	Mar, 2024