



(Thin)DBFP (Ultrathin)DFP Suspended Air-Handling Unit

DBFP: Air Volume: 1000~15000m³/h

DFP: Air Volume: 1000~4000m³/h





Carrier is a leading global provider of innovative HVAC, refrigeration, fire, security and building automation technologies. Supported by the iconic Carrier name, the company's portfolio includes industry-leading brands such as Carrier, Kidde, Edwards, LenelS2 and Automated Logic. Carrier's businesses enable modern life, delivering efficiency, safety, security, comfort, productivity and sustainability across a wide

range of residential, commercial and industrial applications.

In 1998, Time magazine named Dr. Carrier one of its 20 most influential builders and titans of the 20th century.



Model Number Nomenclature

For DBFP080~150	0	Options(Unit external static pressure will reduce if adding options. Please check based on option pressure shown in notes below technical data table) - Please refer to catalogue for jet nozzle allocation 0 : Without below options H : Heating water coil (control optional) N : Nozzle (Domestic sales only, can not combined with other options, no control)
	A	Customer source & control mode D : Domestic, 380V-3Ph-50Hz, with control system option D F : Domestic, 380V-3Ph-50Hz, with control system option F 0 : Domestic, 380V-3Ph-50Hz, with no control 1 : Export, 380V-3Ph-50Hz, with no control
	Z	Filter direction Z : Right & left take out
	Y	Unit direction (Face to return air inlet) Y : Right (water right in) Z : Left (water left in)
	R	Operating condition X : Fresh air condition R : Return air condition
	3	Coil performance 3 : Coil with rated capacity 5 : Coil with high capacity
	1	External static pressure code 1 : 50Pa 2 : 100Pa 3 : 150Pa 4 : 200Pa 5 : 250Pa 6 : 300Pa 7 : 350Pa 8 : 400Pa M : Maximum external static pressure for each unit size, refer to catalogue for details
	DBFP120	Unit size 100 : 10000 m ³ /h
	DBFP	Product series DBFP : Air handling unit
	H	Options(Unit external static pressure will reduce if adding options. Please check based on option pressure shown in notes below technical data table) - Heating coil and wet film humidifier is alternative - Please refer to catalogue for jet nozzle allocation 0 : Without below options(omissible) H : Heating coil W : Wet film humidifier F : G3 primary filter (control optional but can not control filter) N : Jet nozzle (domestic sales only, can not combined with other options, no control) R : Heating coil + G3 primary filter (can control coil but can not control filter) S : Wet film humidifier + G3 primary filter (can control humidifier but can not control filter)
For DBFP010~060	A	Customer source & control mode D : Domestic, 380V-3Ph-50Hz, with control system option D F : Domestic, 380V-3Ph-50Hz, with control system option F 0 : Domestic, 380V-3Ph-50Hz, with no control 1 : Export, 380V-3Ph-50Hz, with no control
	D	Filter direction D : Bottom take out Z : Right & left take out
	Y	Water direction (Face to return air inlet) Y : Right (water right in) Z : Left (water left in)
	R	Operating condition X : Fresh air condition R : Return air condition
	3	Coil performance 3 : Coil with rated capacity 5 : Coil with high capacity
	H	External static pressure H : High static pressure L : Low static pressure
	DBFP020	Unit size 015 : 1500 m ³ /h
	DBFP	Product series DBFP : Air handling unit
	H	Options(Unit external static pressure will reduce if adding options. Please check based on option pressure shown in notes below technical data table) Heating coil, wet film humidifier, G3 primary filter option (heating coil and wet film humidifier is alternative) 0 : Without below options H : Heating coil W : Wet film humidifier F : G3 primary filter R : Heating coil + G3 primary filter S : Wet film humidifier + G3 primary filter
	0	Customer source 0 : Domestic,380V-3Ph-50Hz 1 : Export,380V-3Ph-50Hz
For all DFP	Z	Filter direction Z : Right & left take out
	Y	Unit direction (Face to return air inlet) Y : Right (water right in) Z : Left (water left in)
	R	Operating condition X : Fresh air condition R : Return air condition
	H	Coil performance L : Coil with rated capacity H : Coil with high capacity
	020	Unit size 010 : 1000 m ³ /h 015 : 1500 m ³ /h 020 : 2000 m ³ /h 030 : 3000 m ³ /h 040 : 4000 m ³ /h
	DFP	Product series DFP : Air handling unit

Air Volume

DBFP:1000~15000 m³/h DFP:1000~4000 m³/h

Features

- DBFP air handling unit is a thin low-noise air handling unit with variable air volumes specially designed and produced by our company to meet the tendency of compact storey height in China and the rest of world.
- Its major parts include the high efficiency coil, low-noise fan, casing, drain pan, pre filter and hanger:
- In general, it is characterized with excellent cooling performance, low noise, thin height, compact structure, light weight and easy installation. Furthermore, if equipped with a frequency or pressure regulating controller, it is able to run on the basis of variable air volume, according to different seasonal conditions and airconditioning occasions. It is especially suitable for a variety of airconditioning engineering applications where storey heights of buildings are compact. (Moreover, to meet the requirements of super compact air-conditioners, the latest DFP 010~040 ultrathin lifting unit is released, with the air volume range of 1000m³/h~4000m³/h and a height of only 380mm. For detailed performance and dimensions, see the following)

High-efficiency heat transfer fin

- The coil adopts the high-efficiency heat transfer fin, whose heat transfer efficiency increases by 60% compared with the first generation fin. The coil is constructed of high-quality copper tubes and aluminum fins, which integrated by advanced mechanical expanders. Sealing test pressure is 2.8MPa.

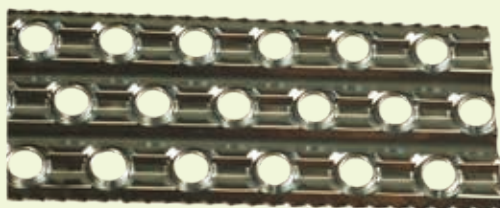

Low noise fan motor

- The precise dynamic balancing calibration for the low-noise high-efficiency external rotor fan (for DBFP 040~060 units), compact straight-coupling fan (for DBFP 010~030 units) and belt drive fan (for DBFP 080~150 units) ensures the extremely stable operation of the unit, and enables the unit to be featured with low noise and higher static pressure.

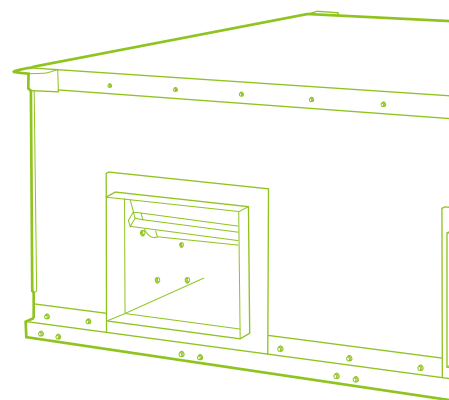
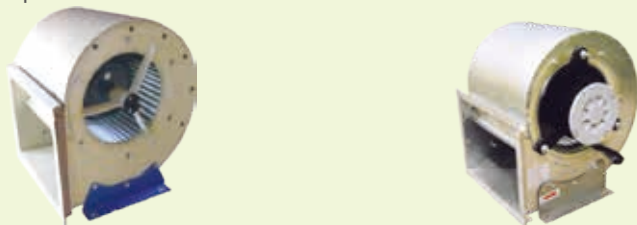

Robust structure

- Constructed of high-quality galvanized steel sheets, the casing structure is rust and erosion resistant, eye-pleasing and durable. The casing is internally lined with sound-absorbing and thermal insulation materials, and characterized with high strength, good thermal insulation and low noise.

Drain pan and hanger

- The elaborately designed drain pan and thickly lined thermal insulation ensure the unit to be free of commonly-seen condensation under severe conditions, and thus they are especially fitted for suspended installation.
- The lug and hanger frame are designed reasonably for easy installation and saving the space height of buildings.



Filters designed for easy maintenance

- Special designed removable filter can be easily drawn out from both sides of the unit in a folding way, it is suitable for compact space, maintain and clean is easily. (Bottom drawn out filters are available for DBFP 010~060).



Technical Data

Model	Air volumn m ³ /h	Dimension W×L×H mm	Motor kW-poles	Input power kW	Fan/Motor quantity	External Static pressure Pa	Return air condition						Fresh air condition						Net weight kg
							Cooling Cap. kW	Water flow (cooling) l/s	Water pressure drop (cooling) kPa	Heating Cap. kW	Water flow (heating) l/s	Water pressure drop (heating) kPa	Cooling Cap. kW	Water flow (cooling) l/s	Water pressure drop (cooling) kPa	Heating Cap. kW	Water flow (heating) l/s	Water pressure drop (heating) kPa	
DBFP010L3	1000	680×986×380	0.20-4	0.32	1/1	130	5.0	0.24	16.2	11.0	0.26	11.1	12.6	0.60	53.4	13.2	0.31	14.2	46
DBFP010H3			0.25-4	0.40		220													47
DBFP015L3	1500	875×986×380	0.25-4	0.40	1/1	115	8.0	0.38	21.8	16.8	0.40	16.7	19.0	0.91	50.4	19.8	0.47	13.3	53
DBFP015H3			0.32-4	0.48		215													55
DBFP020L3	2000	872×986×500	0.32-4	0.58	1/1	220	11.1	0.53	22.0	22.6	0.54	23.2	25.3	1.21	53.7	26.4	0.63	14.2	63
DBFP020H3			0.55-4	0.79		280													64
DBFP025L3	2500	1018×986×500	0.45-4	0.73	1/1	195	13.9	0.66	25.9	28.2	0.67	27.0	31.0	1.48	53.2	32.7	0.78	14.3	67
DBFP025H3			0.55-4	0.86		250													70
DBFP030L3	3000	1166×986×500	0.55-4	0.98	1/1	150	17.1	0.82	30.1	34.1	0.82	30.8	38.7	1.85	87.9	39.7	0.95	22.5	75
DBFP030H3			0.55-4	1.05		200													75
DBFP040L3	4000	1458×986×500	0.45-4	1.46	2/2	220	22.1	1.05	31.1	44.9	1.07	29.3	53.4	2.56	86.8	53.5	1.28	21.1	108
DBFP040H3			0.55-4	1.52		300													112
DBFP050L3	5000	1752×986×500	0.55-4	1.52	2/2	290	29.0	1.39	48.4	57.0	1.36	42.8	64.1	3.07	81.7	65.7	1.57	20.8	123
DBFP050H3			0.80-4	2.22		375													127
DBFP060L3	6000	2044×986×500	0.55-4	1.60	2/2	230	34.7	1.66	57.4	68.0	1.63	55.8	78.1	3.74	104.0	79.3	1.90	25.9	134
DBFP060H3			0.80-4	2.22		350													138
DBFP08013	8000	1710×1413×595	2.2-4	2.61	2/1	50	46.6	2.23	52.3	89.5	2.14	47.2	101.8	4.87	97.8	103.0	2.46	24.4	198
DBFP08023						100													
DBFP08033						150													
DBFP08043						200													
DBFP080M3						235													
DBFP10013	10000	1970×1413×595	2.2-4	2.61	2/1	50	56.1	2.68	53.9	110.9	2.65	51.7	128.3*	5.58	138.7	130.8	3.13	41.6	212
DBFP10023						100													
DBFP10033			150																
DBFP10043			200																
DBFP10053			250																
DBFP10063			300																
DBFP10073			350																
DBFP10083			400																
DBFP100M3			440																
DBFP12013			12000	1970×1546×675		3.0-4													3.51
DBFP12023	100																		
DBFP12033	150																		
DBFP12043	200																		
DBFP12053	250																		
DBFP12063	300																		
DBFP12073	350																		
DBFP12083	400																		
DBFP120M3	430																		
DBFP15013	15000	2060×1595×712			4.0-4	4.62	2/1	50	90.6	4.33	71.9	171.26	4.10	63.4	198.2*	7.52	146.6	206.8	4.95
DBFP15023			100																
DBFP15033			150																
DBFP15043			200																
DBFP15053			250																
DBFP15063			300																
DBFP150M3			330																

The cooling capa with * is not the performance under 5 °C water temperature raise

Standard Air Conditions:

Cooling: Entering Water 7 °C, Temperature Rise 5 °C, Entering Air DB 27 °C, WB 19.5 °C.

Heating: Entering Water 60 °C, Leaving Water 50 °C, Entering Air DB 15 °C

Fresh Air Conditions:

Cooling: Entering Water 7 °C, Temperature Rise 5 °C, Entering Air DB 35 °C, WB 28 °C.

Heating: Entering Water 60 °C, Leaving Water 50 °C, Entering Air DB 7 °C

Notes:

1.Face the return air inlet side to judge connection direction.

2.Motor input power refers to total motor input power.

3.Above external static pressure is for standard unit. Minus 50 pa for unit with wet film humidifier, minus 70 pa for unit with G3 filter, for unit with heating coil, please reduce pressure drop according to heating coil performance.

Technical Data

Model	Air volum m ³ /h	Dimension W×L×H mm	Motor kW-poles	Input power kW	Fan/Motor quantity	External Static pressure Pa	Return air condition						Fresh air condition						Net weight kg	
							Cooling Cap. kW	Water flow (cooling) l/s	Water pressure drop (cooling) kPa	Heating Cap. kW	Water flow (heating) l/s	Water pressure drop (heating) kPa	Cooling Cap. kW	Water flow (cooling) l/s	Water pressure drop (cooling) kPa	Heating Cap. kW	Water flow (heating) l/s	Water pressure drop (heating) kPa		
DBFP010L5	1000	680×986×380	0.20-4	0.32	1/1	90	6.6	0.31	9.1	12.5	0.30	7.5	15.8	0.76	44.0	15.0	0.36	9.8	49	
DBFP010H5			0.25-4	0.40		175													50	
DBFP015L5	1500	875×986×380	0.25-4	0.40	1/1	70	10.1	0.48	10.9	18.7	0.45	9.7	24.0	1.15	57.7	22.6	0.54	12.6	56	
DBFP015H5			0.32-4	0.48		170													58	
DBFP020L5	2000	872×986×500	0.32-4	0.58	1/1	160	13.0	0.62	10.3	24.8	0.59	8.1	31.4	1.50	46.8	30.0	0.72	10.6	67	
DBFP020H5			0.55-4	0.79		230													68	
DBFP025L5	2500	1018×986×500	0.45-4	0.73	1/1	150	16.6	0.79	18.9	31.1	0.74	10.0	39.7	1.90	58.9	37.5	0.90	13.1	75	
DBFP025H5			0.55-4	0.86		210													75	
DBFP030L5	3000	1166×986×500	0.55-4	0.98	1/1	115	20.3	0.97	28.5	37.4	0.90	13.4	49.5	2.37	101.1	45.5	1.09	21.1	81	
DBFP030H5			0.55-4	1.05		150													81	
DBFP040L5	4000	1458×986×500	0.45-4	1.46	2/2	185	27.9	1.33	31.6	50.1	1.20	21.0	65.5	3.13	81.6	60.5	1.45	17.2	115	
DBFP040H5			0.55-4	1.52		265													119	
DBFP050L5	5000	1752×986×500	0.55-4	1.52	2/2	240	37.5	1.79	61.8	63.4	1.52	46.5	80.4	3.84	76.5	74.8	1.79	16.4	129	
DBFP050H5			0.80-4	2.22		330													133	
DBFP060L5	6000	2044×986×500	0.55-4	1.60	2/2	195	44.6	2.13	66.4	75.8	1.81	50.1	98.7	4.72	109.9	90.5	2.17	22.8	142	
DBFP060H5			0.80-4	2.22		305													146	
DBFP08015	8000	1710×1413×595	2.2-4	2.61	2/1	50	60.3	2.89	60.0	105.4	2.52	45.9	130.5	6.24	85.9	120.8	2.89	18.2	214	
DBFP08025						100														
DBFP08035						150														
DBFP080M5						185														
DBFP10015	10000	1970×1413×595	2.2-4	2.61	2/1	50	72.7	3.48	57.8	130.4	3.12	46.6	160.5*	7.38	113.5	150.0	3.59	26.4	230	
DBFP10025						100														
DBFP10035			3.0-4	3.51		150													244	
DBFP10045						200														
DBFP10055			4.0-4	4.62		250													254	
DBFP10065						300														
DBFP10075						350														
DBFP100M5						390														
DBFP12015	12000	1970×1546×675	3.0-4	3.51	2/1	50	93.6	4.48	70.6	159.3	3.81	51.1	198.3	9.49	117.4	184.1	4.40	25.0	242	
DBFP12025						100														
DBFP12035			4.0-4	4.62		150													252	
DBFP12045						200														
DBFP12055			5.5-4	6.27		250													278	
DBFP12065						300														
DBFP12075						350														
DBFP120M5						380														
DBFP15015	15000	2060×1595×712	4.0-4	4.62	2/1	50	116.9	5.59	75.2	198.7	4.75	54.5	238.6*	9.51	126.7	228.1	5.46	39.6	292	
DBFP15025						100														
DBFP15035			150	5.5-4		6.27													200	316
DBFP15045																			250	
DBFP15055			250																	
DBFP150M5																			280	

The cooling capa with * is not the performance under 5°C water temperature raise
 Standard Air Conditions:
 Cooling: Entering Water 7°C, Temperature Rise 5°C, Entering Air DB 27°C, WB 19.5°C.
 Heating: Entering Water 60°C, Leaving Water 50°C, Entering Air DB 15°C
 Fresh Air Conditions:
 Cooling: Entering Water 7°C, Temperature Rise 5°C, Entering Air DB 35°C, WB 28°C.
 Heating: Entering Water 60°C, Leaving Water 50°C, Entering Air DB 7°C

- Notes:
- 1.Face the return air inlet side to judge connection direction.
 - 2.Motor input power refers to total motor input power.
 - 3.Above external static pressure is for standard unit. Minus 50 pa for unit with wet film humidifier, minus 70 pa for unit with G3 filter, for unit with heating coil, please reduce pressure drop according to heating coil performance.

Dimension of DBFP 010~030

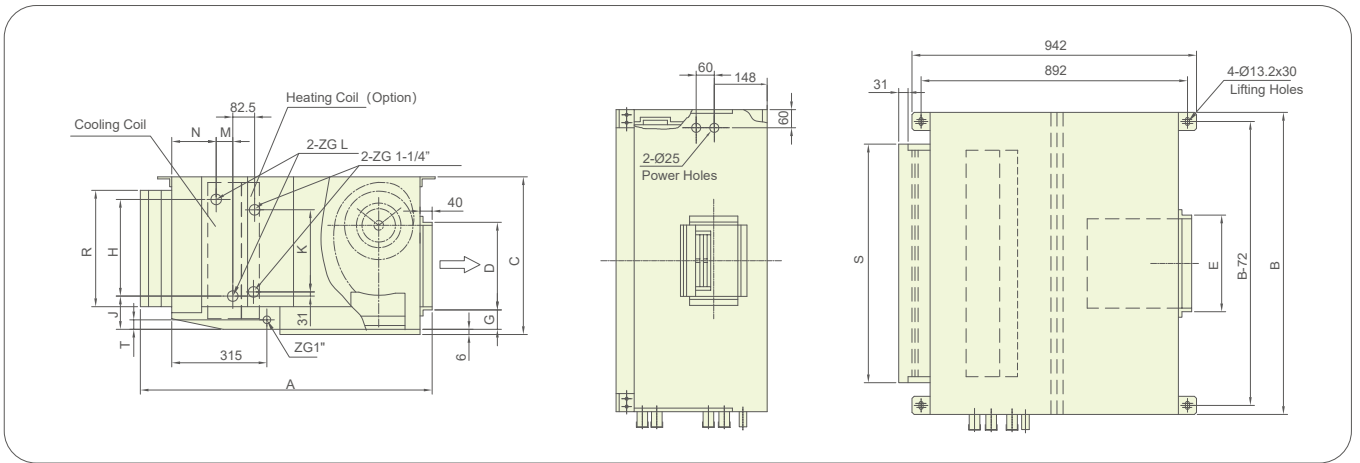

Model	L			W			H			Dimention of outlet			Connection direction and dimention				Dimention of return air inlet		T
	A	B	C	D	E	G	H	J	K	L		M	N	R	S				
										Fresh air	Return air								
DBFP010-3	986	680	380	249	236	39	200	116	114	1-1/4"	1-1/4"	44	158	264	531	34			
DBFP010-5																			
DBFP015-3	986	875	380	249	236	39	200	116	114	1-1/4"	1-1/4"	44	158	264	726	34			
DBFP015-5																			
DBFP020-3	986	872	500	225	303	57	320	108	254	1-1/4"	1-1/4"	44	158	385	721	31			
DBFP020-5												88	114						
DBFP025-3	986	1018	500	225	303	57	320	108	254	1-1/4"	1-1/4"	44	158	385	869	31			
DBFP025-5												88	114						
DBFP030-3	986	1166	500	225	303	57	320	108	254	1-1/4"	1-1/4"	44	158	385	1017	31			
DBFP030-5										1-1/2"	1-1/4"	88	114						

Dimension of DBFP 040~060

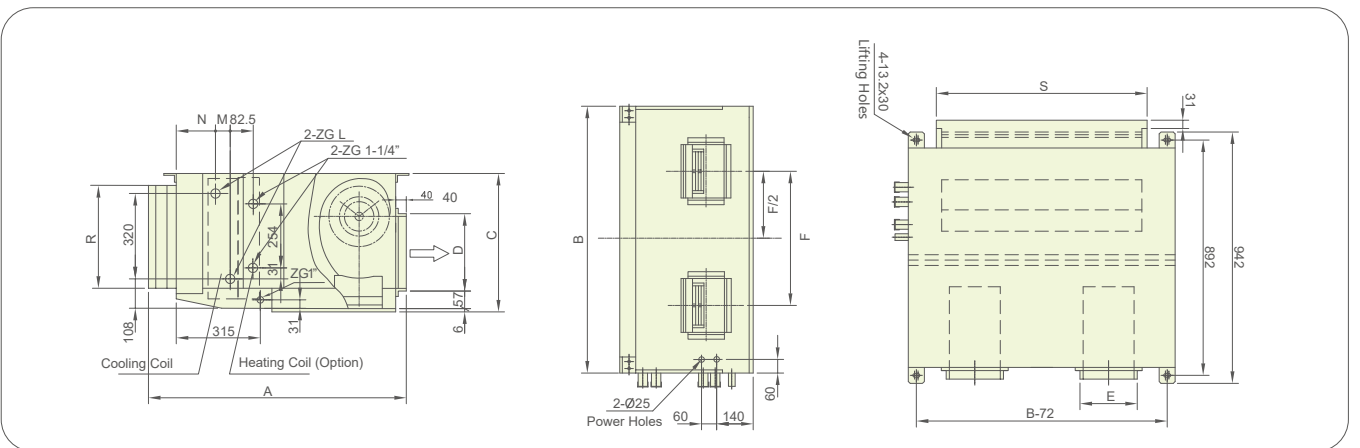

Model	L			W			H			Dimention of outlet			Connection direction and dimention				Dimention of return air inlet	
	A	B	C	D	E	F	L		M	N	R	S						
							Fresh air	Return air										
DBFP040-3	986	1458	500	229	303	728	1-1/2"	1-1/4"	44	158	385	1307						
DBFP040-5									88	114								
DBFP050-3	986	1752	500	229	303	875	1-1/2"	1-1/4"	44	158	385	1601						
DBFP050-5									88	114								
DBFP060-3	986	2044	500	229	303	1021	2"	1-1/4"	44	158	385	1893						
DBFP060-5									88	114			726					

Note: for DBFP010~060 units, the lug is located on the top of the unit for DBFP080~150 units, the lug is located at the bottom of the unit. When preparing a hanging bar, take into account its length

Dimension of DBFP 080~100

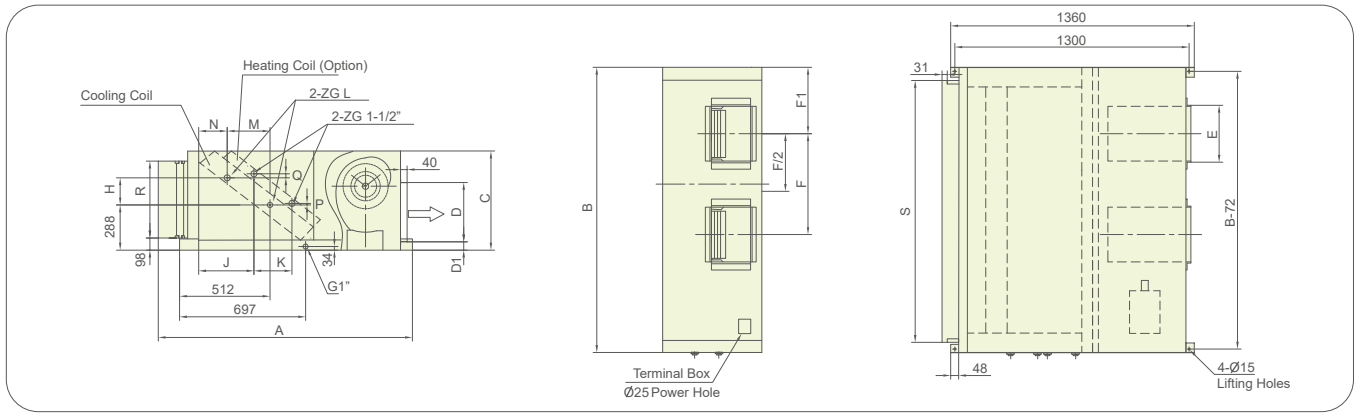

Model	L	W	H	Dimension of outlet					Connection direction and dimension								Dimension of return air inlet		
				A	B	C	D	E	F	F1	D1	H	J	K	L		M	N	P
DBFP080-3	1413	1710	595	330	309	553	391	69	105	355	205	2"	2"	241	171	3	58	436	1553
DBFP080-5	1413	1710	595	330	309	553	391	69	71	344	214	2"	2"	268	139	11	103	436	1553
DBFP100-3	1413	1970	595	330	395	689	419	69	105	355	205	2"	2"	241	171	3	58	436	1813
DBFP100-5	1413	1970	595	330	395	689	419	69	71	344	214	2"	2"	268	139	11	103	436	1813

Dimension of DBFP 120~150

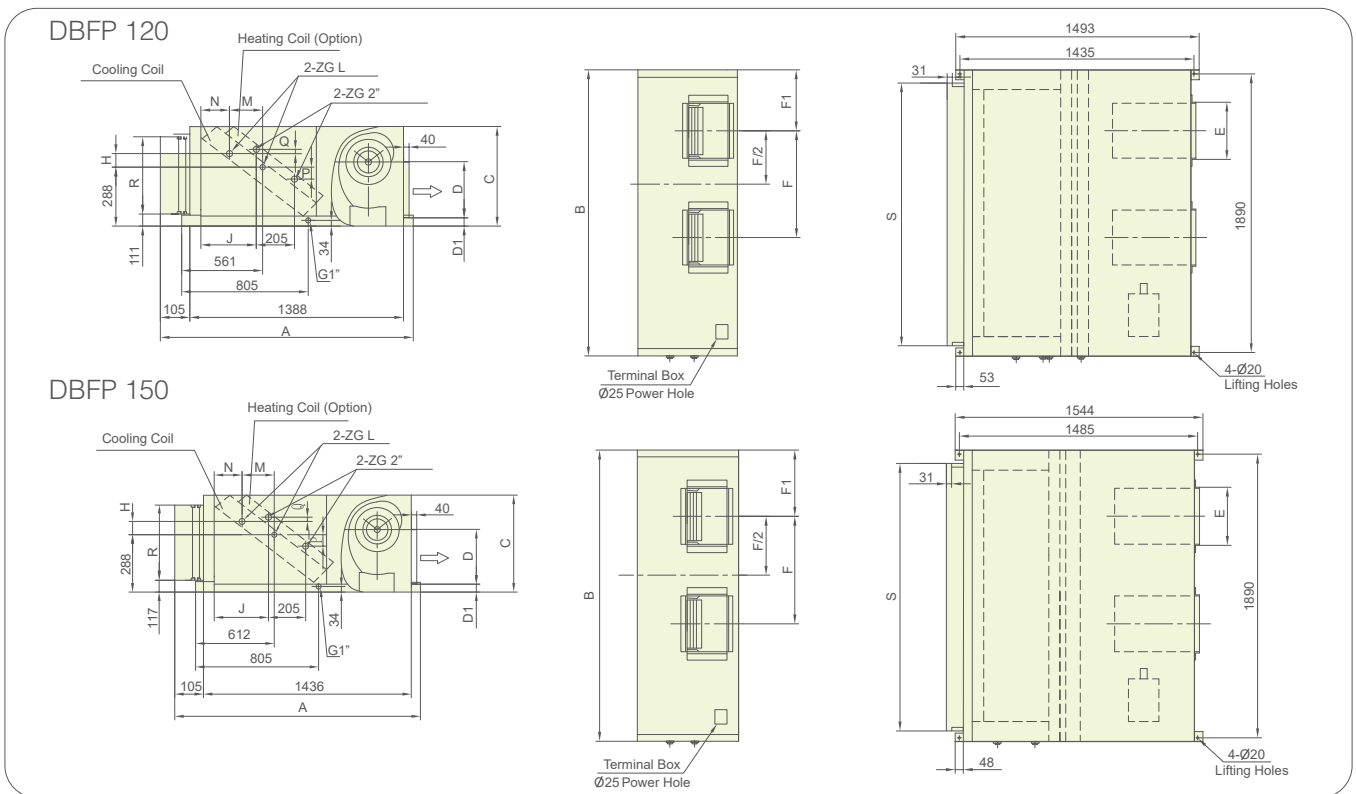

Model	L	W	H	Dimension of outlet					Connection direction and dimension								Dimension of return air inlet	
				A	B	C	D	E	F	F1	D1	H	J	L		M	N	P
DBFP120-3	1546	1970	675	345	395	689	471	75.5	92	458	251	2-1/2"	2-1/2"	274	1.5	56.5	498	1813
DBFP120-5	1546	1970	675	345	395	689	471	75.5	70	458	268	2-1/2"	2-1/2"	247	2.5	92.5	498	1813
DBFP150-3	1595	2060	712	406	445	558	485	67	92	509.5	251	2-1/2"	2-1/2"	326	2.5	57.5	529	1903
DBFP150-5	1595	2060	712	406	445	558	485	67	70	509.5	268	2-1/2"	2-1/2"	299	2.5	92.5	529	1903

Note: for DBFP010~060 units, the lug is located on the top of the unit for DBFP080~150 units, the lug is located at the bottom of the unit. When preparing a hanging bar, take into account its length

DFP Ultrathin Unit



DFP Technical Data

Model	W×L×H mm	Air flow m³/h	Motor kW-poles	Input power kW	External Static pressure Pa	Return air condition						Fresh air condition						Net weight kg
						Cooling Cap. kW	Water flow (cooling) l/s	Water pressure drop (cooling) kPa	Heating Cap. kW	Water flow (heating) l/s	Water pressure drop (heating) kPa	Cooling Cap. kW	Water flow (cooling) l/s	Water pressure drop (cooling) kPa	Heating Cap. kW	Water flow (heating) l/s	Water pressure drop (heating) kPa	
DFP010L	680×986×380	1000	0.18×1	0.4	200	5.0	0.24	10.10	11.0	0.26	11.1	12.6	0.60	53.4	13.2	0.31	14.2	48
DFP010H		1000	0.18×1	0.4	150	6.6	0.31	8.3	12.5	0.30	7.5	15.8	0.76	44.0	15.0	0.36	9.8	50
DFP015L	875×986×380	1500	0.25×1	0.4	185	8.0	0.38	14.5	16.8	0.40	16.7	19.0	0.91	50.4	19.8	0.47	13.3	55
DFP015H		1500	0.25×1	0.4	145	10.1	0.48	10.9	18.7	0.45	9.7	24.0	1.15	57.7	22.6	0.54	12.6	58
DFP020L	1018×986×380	2000	0.32×1	0.58	95	10.6	0.51	21.8	21.9	0.52	23.0	25.0	1.20	58.3	26.9	0.64	18.7	65
DFP020H		2000	0.32×1	0.58	65	12.0	0.57	7.9	24.8	0.59	10.0	30.4	1.45	50.0	29.8	0.71	14.3	67
DFP030L	1458×986×380	3000	0.32×2	1.16	140	16.8	0.80	30.5	33.1	0.79	31.0	38.1	1.82	74.2	40.3	0.96	25.0	92
DFP030H		3000	0.32×2	1.16	110	20.0	0.96	15.3	37.4	0.89	14.3	48.0	2.30	77.5	45.8	1.10	21.5	95
DFP040L	1752×986×380	4000	0.32×2	1.16	85	21.8	1.04	25.5	45.3	1.08	26.6	51.1	2.45	89.7	54.4	1.30	29.3	105
DFP040H		4000	0.32×2	1.16	55	27.4	1.31	25.3	52.3	1.25	24.9	62.9	3.01	89.9	61.1	1.46	34.9	109

Standard Air Conditions:

Cooling: Entering Water 7 C, Temperature Rise 5 C, Entering Air DB 27 C, WB 19.5 C.

Heating: Entering Water 60 C, Leaving Water 50 C, Entering Air DB 15 C.

Fresh Air Conditions:

Cooling: Entering Water 7 C, Temperature Rise 5 C, Entering Air DB 35 C, WB 28 C.

Heating: Entering Water 60 C, Leaving Water 50 C, Entering Air DB 7 C.

Note:

1. Model with L means rated cooling capacity unit, model with H means high cooling capacity unit.

2. Motor input power refers to total motor input power.

3. External static pressure data in the from are for units with standard configuration (w/o heating coil or wet film). Static pressure data should reduce 50Pa with wet film humidifier, reduce 70Pa if with G3 filter, and should reduce pressure drop if add heating coil (Pressure drop of heating coil please refer "2R Heating coil performance data").

4. No control options for DFP.

Dimension of DFP

- Each model of unit has the same top views and sizes.
- ZG1" is drain pan connection. For method of installation, see the Manual for Installation, Operation and Maintenance.

Model	Size			
	A	B	C	D
DFP010L	680	531	608	164
DFP010H				
DFP015L	875	726	803	164
DFP015H				
DFP020L	1018	869	946	156
DFP020H				

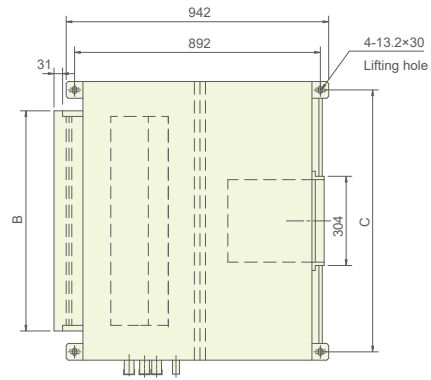
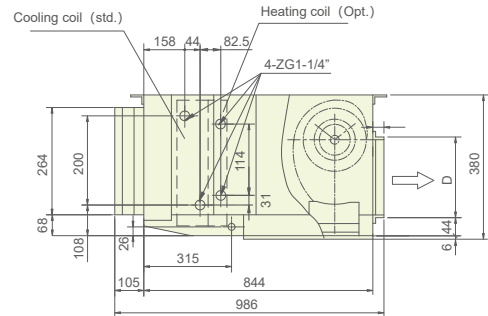
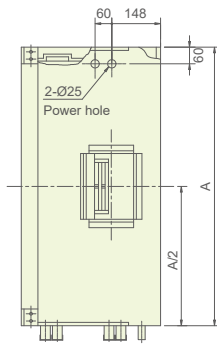

Model	Size						
	A	B	C	D	E	F	G
DFP030L	1458	1307	1386	728	1-1/4"	44	158
DFP030H							
DFP040L	1752	1601	1680	875	1-1/4"	44	158
DFP040H					1-1/2"	55	147

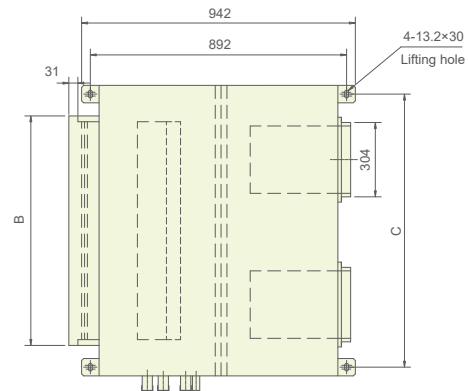
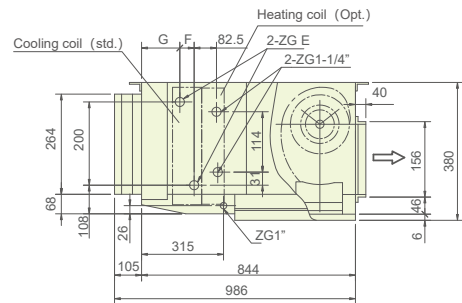
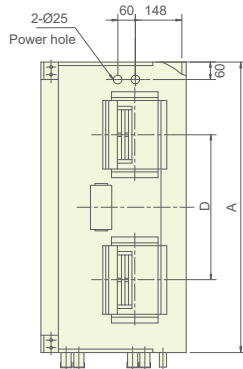

2R Heating coil performance data (Option)

Model	Air volumn m ³ /h	Return air condition				Fresh air condition			
		Heating Cap. kW	Water flow l/m	Water pressure drop kPa	Air pressure drop Pa	Heating Cap. kW	Water flow l/m	Water pressure drop kPa	Air pressure drop Pa
DBFP010	1000	4.8	0.11	1.0	10	5.8	0.14	1.0	10
DBFP015	1500	7.5	0.18	1.0	10	9.0	0.22	1.0	10
DBFP020	2000	10.0	0.24	1.0	10	12.0	0.29	1.0	10
DBFP025	2500	12.6	0.3	1.0	10	15.2	0.36	1.0	10
DBFP030	3000	15.4	0.37	1.0	10	18.4	0.44	1.0	10
DBFP040	4000	20.6	0.5	2.0	10	24.8	0.60	2.8	10
DBFP050	5000	25.9	0.62	3.9	10	31.2	0.75	5.7	10
DBFP060	6000	31.3	0.75	6.9	10	37.7	0.90	10.0	10
DBFP080	8000	38.7	0.93	5.8	15	46.9	1.12	8.3	15
DBFP100	10000	47.7	1.14	10.2	15	57.1	1.37	14.8	15
DBFP120	12000	63.5	1.52	9.3	15	76.7	1.83	13.5	15
DBFP150	15000	79.9	1.91	11.9	15	96.4	2.30	17.1	15
DFP010	1000	4.8	0.11	1.0	10	5.8	0.14	1.0	10
DFP015	1500	7.5	0.18	1.0	10	9.0	0.22	1.0	10
DFP020	2000	9.9	0.24	1.0	10	11.9	0.29	1.0	10
DFP030	3000	15.5	0.37	1.0	10	18.6	0.45	1.0	10
DFP040	4000	20.3	0.49	1.0	10	24.6	0.59	1.0	10

Return air condition: Entering air temp. 15°C DB, Inlet water temp.60°C , Outlet water temp.50°C
 Fresh air condition: Entering air temp. 7°C DB, Inlet water temp.60°C , Outlet water temp.50°C

Technical data of wet film humidifier (option)

Model	Air volumn m ³ /h	Air pressure drop Pa	Thickness of wet film humidifier mm	Maxim humidification kg/h
DBFP010	1000	50	50	1.72
DBFP015	1500	50	50	2.68
DBFP020	2000	50	50	3.79
DBFP025	2500	50	50	4.81
DBFP030	3000	50	50	5.82
DBFP040	4000	50	50	7.86
DBFP050	5000	50	50	9.89
DBFP060	6000	50	50	12.11
DFP010	1000	50	50	1.72
DFP015	1500	50	50	2.68
DFP020	2000	50	50	3.79
DFP030	3000	50	50	5.82
DFP040	4000	50	50	7.86

Note:

1. Air inlet condition: DB36°C, 10%RH

2. If wet film humidifier selected, please take away the pressure drop of humidifier for external and total static pressure drop.

Wiring Diagram of Unit (DBFP 010~060&DFP 010~040)

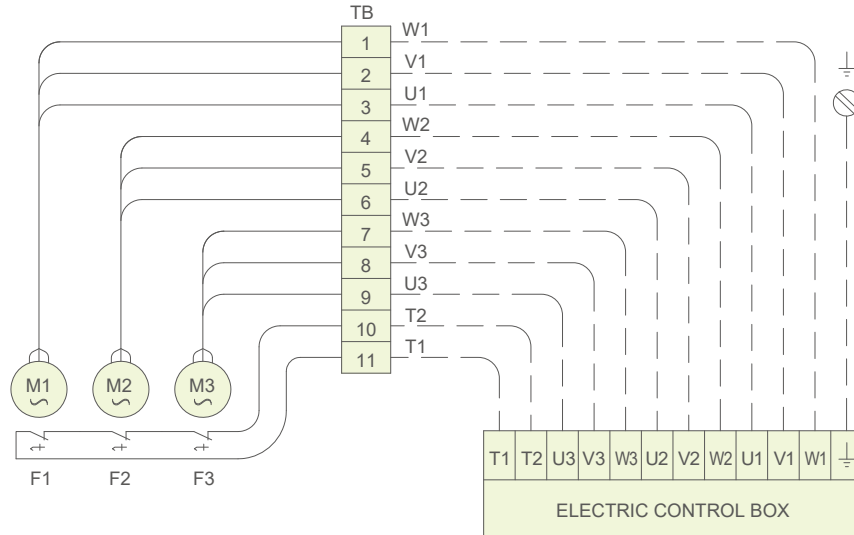

- 1) TB--terminal Block
- 2) Electric control box is the optional accessory
- 3) M1,M2,M3--Three phases external-rotor motor
- 4) F1,F2,F3--motor overheat protector
- 5)-----Customer Wiring
- 6)-----Factory Wiring
- 7) If motor has overheat protector: Three motors--wiring follow the wiring diagram.
Two motors--wiring 1~6 and T1,T2 one motor--wiring 1~3 and T1,T2 please connect T1,T2 into motor control circuit.
- 8) If motor has not overheat protector: Three motor--wiring 1~9.
Two motor--wiring 1~6, One motor--wiring 1~3

Wiring Diagram of Unit (DBFP 080~150)

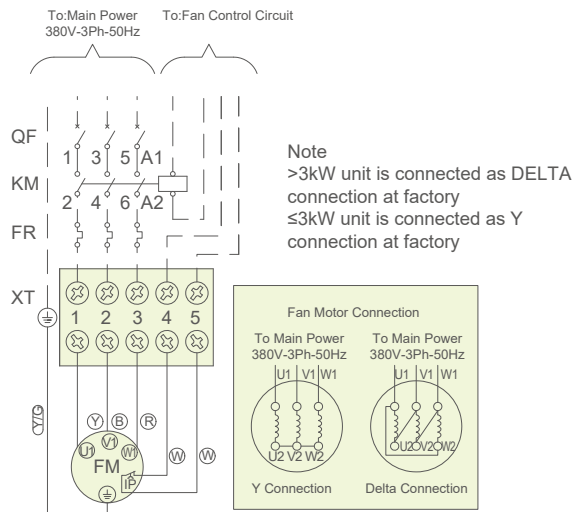

LEGEND

- Factory wiring
- Wiring by installer
- QF Circuit breaker (User option)
- KM Fan contactor (User option)
- M Fan motor
- FR Overload relay (User option)
- XT Terminal block

WIRE COLORS

- ⓐ Green
- Ⓡ Red
- Ⓨ Yellow
- Ⓦ White
- Ⓨ/ⓐ Yellow/Green

ATTENTION

Any warranty is declined in case of field changes of factory wiring and settings

Instruction

1. The application pressure of the surface cooler and the hot water heater should not exceed 1.6MPa. Use pipe thread (wrapped with raw material band) or flange to connect the water inlet pipe and the water outlet pipe. The connection type of the water pipe is "down inlet, up outlet".
2. In consideration of the negative pressure, U water seal must be installed on each condensate drain pipe to connect the sewer. To make the condensate water discharged without obstruction, the drain pipe should have the gradient of slope 1/25 – 1/50.

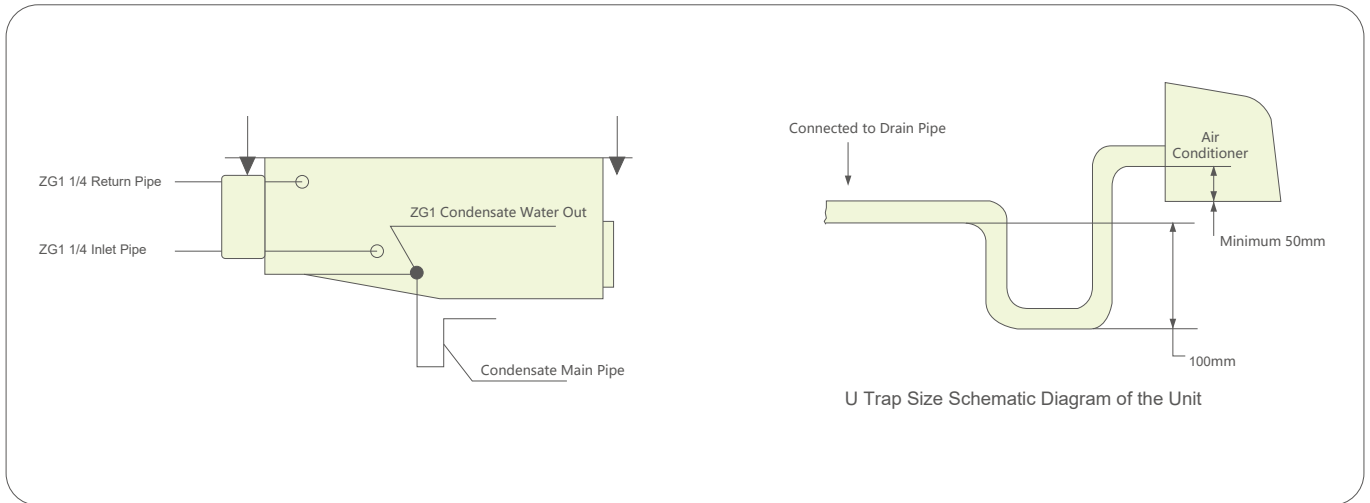

3. Preheat device should be installed in the inlet of fresh air unit, to protect coil from freezing operation with fresh air temperature below 0°C.
4. The unit supply air temperature should be no more than 80°C (heating). If it is, please give us clear indication, we can adopt high temperature bearing special motor.
5. The fan outlet and discharge should be connected with soft connection.
6. The water in the coil should be drawn off completely when the unit is stopped and below freezing temperature. Antifreeze shall be poured into pipe if remaining water cannot be drawn off completely.



Carrier improves the world around us; Carrier improves people's lives; our products and services improve building performance; our culture of improvement will not allow us to rest when it comes to the environment.



www.carrier.com

The Manufacturer reserves the right to change any product specifications without prior notices
©ALL Rights Reserved, Carrier® is a registered trademark of Carrier corporation.

Version:	CAT_DBFP_E-2102-09
Supersede:	CAT_DBFP_E-1906-08
Effective Date:	Feb, 2021