



**(Thin)DBFP**  
**(Ultrathin)DFP**  
**Suspended Air-Handling Unit**

DBFP: Air Volume: 1000~15000m<sup>3</sup>/h  
DFP: Air Volume: 1000~4000m<sup>3</sup>/h



## Turn To The Experts

Carrier is a leading global provider of innovative HVAC, refrigeration, fire, security and building automation technologies.

Supported by the iconic Carrier name, the company's portfolio includes industry-leading brands such as Carrier, Kidde, Edwards, LenelS2 and Automated Logic.

Carrier's businesses enable modern life, delivering efficiency, safety, security, comfort, productivity and sustainability across a wide range of residential, commercial and industrial applications.



In 1998, Time magazine named Dr. Carrier one of its 20 most influential builders and titans of the 20<sup>th</sup> century.



## Model Number Nomenclature

For DBFP080~150	0	Options	0 : Without Below Options	H : Heating coil (without water valve)		
	A	Customer source & control mode	1 : Export, 380V-3Ph-50Hz, with no control			
	Z	Filter direction	Z : Right & left take out			
	Y	Unit direction (Face to return air inlet)	Y : Right (water right in)	Z : Left (water left in)		
	R	Operating condition	X : Fresh air condition	R : Return air condition		
	3	Coil performance	3 : Coil with rated capacity	5 : Coil with high capacity		
	1	External static pressure code	1 : 50Pa	2 : 100Pa	3 : 150Pa	4 : 200Pa
			5 : 250Pa	6 : 300Pa	7 : 350Pa	8 : 400Pa
		M:	Maximum external static pressure for each unit size, refer to catalogue for details			
	DBFP120	Unit size	100 : 10000 m <sup>3</sup> /h			
↑ DBFP	Product series	DBFP : Air handling unit				

For DBFP010~060	H	Options	0 : Without Below Options	H : Heating coil (without water valve)
			W : Wet Film Humidifier	F : G3 Primary Filter
			R : Heating coil (without water valve) + G3 primary filter	S : Wet Film Humidifier + G3 Primary Filter
	A	Customer source & control mode	1 : Export, 380V-3Ph-50Hz, with no control	
	D	Filter direction	D : Bottom take out	Z : Right & left take out
	Y	Water direction (Face to return air inlet)	Y : Right (water right in)	Z : Left (water left in)
	R	Operating condition	X : Fresh air condition	R : Return air condition
	3	Coil performance	3 : Coil with rated capacity	5 : Coil with high capacity
	H	External static pressure	H : High static pressure	L : Low static pressure
	DBFP020	Unit size	015 : 1500 m <sup>3</sup> /h	
↑ DBFP	Product series	DBFP : Air handling unit		

For all DFP	H	Options	0 : Without below options	H : Heating coil (without water valve)	
			W : Wet film humidifier	F : G3 primary filter	
			R : Heating coil (without water valve) + G3 primary filter	S : Wet film humidifier + G3 primary filter	
	0	Customer source	1 : Export, 380V-3Ph-50Hz		
	Z	Filter direction	Z : Right & left take out		
	Y	Unit direction (Face to return air inlet)	Y : Right (water right in)	Z : Left (water left in)	
	R	Operating condition	X : Fresh air condition	R : Return air condition	
	H	Coil performance	L : Coil with rated capacity	H : Coil with high capacity	
	020	Unit size	010 : 1000 m <sup>3</sup> /h	015 : 1500 m <sup>3</sup> /h	020 : 2000 m <sup>3</sup> /h
	↑ DFP	Product series	030 : 3000 m <sup>3</sup> /h	040 : 4000 m <sup>3</sup> /h	DFP : Air handling unit

## Air Volume

DBFP:1000~15000 m<sup>3</sup>/h      DFP:1000~4000 m<sup>3</sup>/h

## Features

- DBFP air handling unit is a thin low-noise air handling unit with variable air volumes specially designed and produced by our company to meet the tendency of compact storey height in China and the rest of world.
- Its major parts include the high efficiency coil, low-noise fan, casing, drain pan, pre filter and hanger:
- In general, it is characterized with excellent cooling performance, low noise, thin height, compact structure, light weight and easy installation. Furthermore, if equipped with a frequency or pressure regulating controller, it is able to run on the basis of variable air volume, according to different seasonal conditions and airconditioning occasions. It is especially suitable for a variety of airconditioning engineering applications where storey heights of buildings are compact. (Moreover, to meet the requirements of super compact air-conditioners, the latest DFP 010~040 ultrathin lifting unit is released, with the air volume range of 1000m<sup>3</sup>/h~4000m<sup>3</sup>/h and a height of only 380mm. For detailed performance and dimensions, see the following)

## High-efficiency heat transfer fin

- The coil adopts the high-efficiency heat transfer fin, whose heat transfer efficiency increases by 60% compared with the first generation fin. The coil is constructed of high-quality copper tubes and aluminum fins, which integrated by advanced mechanical expanders. Sealing test pressure is 2.8MPa.

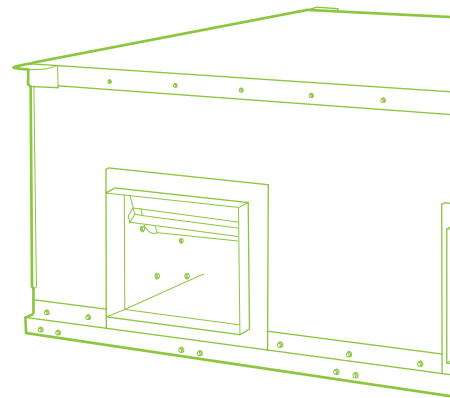
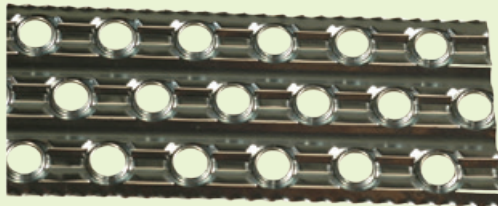

## Low noise fan motor

- The precise dynamic balancing calibration for the low-noise high-efficiency external rotor fan (for DBFP 040~060 units), compact straight-coupling fan (for DBFP 010~030 units) and belt drive fan (for DBFP 080~150 units) ensures the extremely stable operation of the unit, and enables the unit to be featured with low noise and higher static pressure.



## Robust structure

- Constructed of high-quality galvanized steel sheets, the casing structure is rust and erosion resistant, eye-pleasing and durable. The casing is internally lined with sound-absorbing and thermal insulation materials, and characterized with high strength, good thermal insulation and low noise.

## Drain pan and hanger

- The elaborately designed drain pan and thickly lined thermal insulation ensure the unit to be free of commonly-seen condensation under severe conditions, and thus they are especially fitted for suspended installation.
- The lug and hanger frame are designed reasonably for easy installation and saving the space height of buildings.

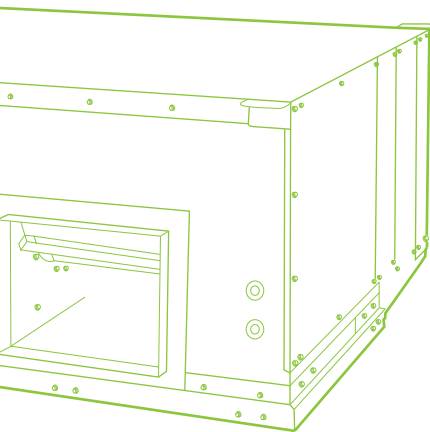

## Filters designed for easy maintenance

- Special designed removable filter can be easily drawn out from both sides of the unit in a folding way, it is suitable for compact space, maintain and clean is easily. (Bottom drawn out filters are available for DBFP 010~060).

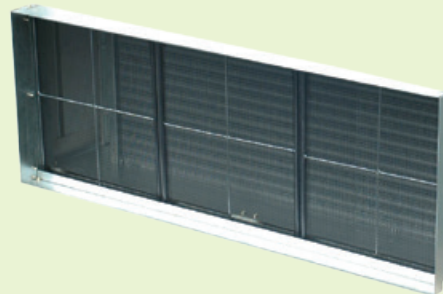

# Technical Data

Model	Air volumn m³/h	Dimenton W×L×H mm	Motor kW-poles	Input power kW	Fan/Motor quantity	Static pressure Pa	Return air condition						Fresh air condition						Net weight kg
							Cooling Cap. kW	Water flow (cooling) l/s	Water pressure drop (cooling) kPa	Heating Cap. kW	Water flow (heating) l/s	Water pressure drop (heating) kPa	Cooling Cap. kW	Water flow (cooling) l/s	Water pressure drop (cooling) kPa	Heating Cap. kW	Water flow (heating) l/s	Water pressure drop (heating) kPa	
DBFP010L3	1000	680×986×380	0.20-4	0.32	1/1	130	5.0	0.24	16.2	11.0	0.26	11.1	12.6	0.60	53.4	13.2	0.31	14.2	46
DBFP010H3			0.25-4	0.40		220													47
DBFP015L3	1500	875×986×380	0.25-4	0.40	1/1	115	8.0	0.38	21.8	16.8	0.40	16.7	19.0	0.91	50.4	19.8	0.47	13.3	53
DBFP015H3			0.32-4	0.48		215													55
DBFP020L3	2000	872×986×500	0.32-4	0.58	1/1	220	11.1	0.53	22.0	22.6	0.54	23.2	25.3	1.21	53.7	26.4	0.63	14.2	63
DBFP020H3			0.55-4	0.79		280													64
DBFP025L3	2500	1018×986×500	0.45-4	0.73	1/1	195	13.9	0.66	25.9	28.2	0.67	27.0	31.0	1.48	53.2	32.7	0.78	14.3	67
DBFP025H3			0.55-4	0.86		250													70
DBFP030L3	3000	1166×986×500	0.55-4	0.98	1/1	150	17.1	0.82	30.1	34.1	0.82	30.8	38.7	1.85	87.9	39.7	0.95	22.5	75
DBFP030H3			0.55-4	1.05		200													75
DBFP040L3	4000	1458×986×500	0.45-4	1.46	2/2	220	22.1	1.05	31.1	44.9	1.07	29.3	53.4	2.56	86.8	53.5	1.28	21.1	108
DBFP040H3			0.55-4	1.52		300													112
DBFP050L3	5000	1752×986×500	0.55-4	1.52	2/2	290	29.0	1.39	48.4	57.0	1.36	42.8	64.1	3.07	81.7	65.7	1.57	20.8	123
DBFP050H3			0.80-4	2.22		375													127
DBFP060L3	6000	2044×986×500	0.55-4	1.60	2/2	230	34.7	1.66	57.4	68.0	1.63	55.8	78.1	3.74	104.0	79.3	1.90	25.9	134
DBFP060H3			0.80-4	2.22		350													138
DBFP08013	8000	1710×1413×595	2.2-4	2.61	2/1	50	46.6	2.23	52.3	89.5	2.14	47.2	101.8	4.87	97.8	103.0	2.46	24.4	198
DBFP08023						100													
DBFP08033						150													
DBFP08043						200													
DBFP080M3						235													
DBFP10013	10000	1970×1413×595	2.2-4	2.61	2/1	50	56.1	2.68	53.9	110.9	2.65	51.7	128.3*	5.58	138.7	130.8	3.13	41.6	212
DBFP10023						100													
DBFP10033						150													
DBFP10043						200													
DBFP10053						250													
DBFP10063			300																
DBFP10073			350																
DBFP10083			400																
DBFP100M3			440																
DBFP12013			12000	1970×1546×675		3.0-4													3.51
DBFP12023	100																		
DBFP12033	150																		
DBFP12043	200																		
DBFP12053	250																		
DBFP12063	300																		
DBFP12073	350																		
DBFP12083	400																		
DBFP120M3	430																		
DBFP15013	15000	2060×1595×712			4.0-4	4.62	2/1	50	90.6	4.33	71.9	171.26	4.10	63.4	198.2*	7.52	146.6	206.8	4.95
DBFP15023			100																
DBFP15033			150																
DBFP15043			200																
DBFP15053			250																
DBFP15063			300																
DBFP150M3			330																
					5.5-4	6.27													

The cooling capa with \* is not the performance under 5 C water temperature raise  
 Standard Air Conditions:  
 Cooling: Entering Water 7 C, Temperature Rise 5 C, Entering Air DB 27 C, WB 19.5 C.  
 Heating: Entering Water 60 C, Leaving Water 50 C, Entering Air DB 15 C  
 Fresh Air Conditions:  
 Cooling: Entering Water 7 C, Temperature Rise 5 C, Entering Air DB 35 C, WB 28 C.  
 Heating: Entering Water 60 C, Leaving Water 50 C, Entering Air DB 7 C

Notes:

- 1.Face the return air inlet side to judge connection direction.
- 2.Motor input power refers to total motor input power.
- 3.Above static pressure is for standard unit. Minus 50 pa for unit with wet film humidifier, minus 70 pa for unit with G3 filter, for unit with heating coil, please reduce pressure drop according to heating coil performance.

## Technical Data

Model	Air volume m <sup>3</sup> /h	Dimension W×L×H mm	Motor kW-poles	Input power kW	Fan/Motor quantity	Static pressure Pa	Return air condition						Fresh air condition						Net weight kg
							Cooling Cap. kW	Water flow (cooling) l/s	Water pressure drop (cooling) kPa	Heating Cap. kW	Water flow (heating) l/s	Water pressure drop (heating) kPa	Cooling Cap. kW	Water flow (cooling) l/s	Water pressure drop (cooling) kPa	Heating Cap. kW	Water flow (heating) l/s	Water pressure drop (heating) kPa	
DBFP010L5	1000	680×986×380	0.20-4	0.32	1/1	90	6.6	0.31	9.1	12.5	0.30	7.5	15.8	0.76	44.0	15.0	0.36	9.8	49
DBFP010H5			0.25-4	0.40		175													50
DBFP015L5	1500	875×986×380	0.25-4	0.40	1/1	70	10.1	0.48	10.9	18.7	0.45	9.7	24.0	1.15	57.7	22.6	0.54	12.6	56
DBFP015H5			0.32-4	0.48		170													58
DBFP020L5	2000	872×986×500	0.32-4	0.58	1/1	160	13.0	0.62	10.3	24.8	0.59	8.1	31.4	1.50	46.8	30.0	0.72	10.6	67
DBFP020H5			0.55-4	0.79		230													68
DBFP025L5	2500	1018×986×500	0.45-4	0.73	1/1	150	16.6	0.79	18.9	31.1	0.74	10.0	39.7	1.90	58.9	37.5	0.90	13.1	75
DBFP025H5			0.55-4	0.86		210													75
DBFP030L5	3000	1166×986×500	0.55-4	0.98	1/1	115	20.3	0.97	28.5	37.4	0.90	13.4	49.5	2.37	101.1	45.5	1.09	21.1	81
DBFP030H5			0.55-4	1.05		150													81
DBFP040L5	4000	1458×986×500	0.45-4	1.46	2/2	185	27.9	1.33	31.6	50.1	1.20	21.0	65.5	3.13	81.6	60.5	1.45	17.2	115
DBFP040H5			0.55-4	1.52		265													119
DBFP050L5	5000	1752×986×500	0.55-4	1.52	2/2	240	37.5	1.79	61.8	63.4	1.52	46.5	80.4	3.84	76.5	74.8	1.79	16.4	129
DBFP050H5			0.80-4	2.22		330													133
DBFP060L5	6000	2044×986×500	0.55-4	1.60	2/2	195	44.6	2.13	66.4	75.8	1.81	50.1	98.7	4.72	109.9	90.5	2.17	22.8	142
DBFP060H5			0.80-4	2.22		305													146
DBFP08015	8000	1710×1413×595	2.2-4	2.61	2/1	50	60.3	2.89	60.0	105.4	2.52	45.9	130.5	6.24	85.9	120.8	2.89	18.2	214
DBFP08025						100													
DBFP08035						150													
DBFP080M5						185													
DBFP10015	10000	1970×1413×595	2.2-4	2.61	2/1	50	72.7	3.48	57.8	130.4	3.12	46.6	160.5*	7.38	113.5	150.0	3.59	26.4	230
DBFP10025						100													
DBFP10035						150													
DBFP10045						200													
DBFP10055			250																
DBFP10065			300																
DBFP10075			350																
DBFP100M5			390																
DBFP12015	12000	1970×1546×675	3.0-4	3.51	2/1	50	93.6	4.48	70.6	159.3	3.81	51.1	198.3	9.49	117.4	184.1	4.40	25.0	242
DBFP12025			100																
DBFP12035			150																
DBFP12045			200																
DBFP12055			250																
DBFP12065			300																
DBFP12075			350																
DBFP120M5			380																
DBFP15015	15000	2060×1595×712	4.0-4	4.62	2/1	50	116.9	5.59	75.2	198.7	4.75	54.5	238.6*	9.51	126.7	228.1	5.46	39.6	292
DBFP15025			100																
DBFP15035			150																
DBFP15045			200																
DBFP15055			250																
DBFP150M5			280																

The cooling capa with \* is not the performance under 5°C water temperature raise

Standard Air Conditions:

Cooling: Entering Water 7°C, Temperature Rise 5°C, Entering Air DB 27°C, WB 19.5°C.

Heating: Entering Water 60°C, Leaving Water 50°C, Entering Air DB 15°C

Fresh Air Conditions:

Cooling: Entering Water 7°C, Temperature Rise 5°C, Entering Air DB 35°C, WB 28°C.

Heating: Entering Water 60°C, Leaving Water 50°C, Entering Air DB 7°C

Notes:

1.Face the return air inlet side to judge connection direction.

2.Motor input power refers to total motor input power.

3.Above static pressure is for standard unit. Minus 50 pa for unit with wet film humidifier, minus 70 pa for unit with G3 filter, for unit with heating coil, please reduce pressure drop according to heating coil performance.

## Dimension of DBFP 010~030

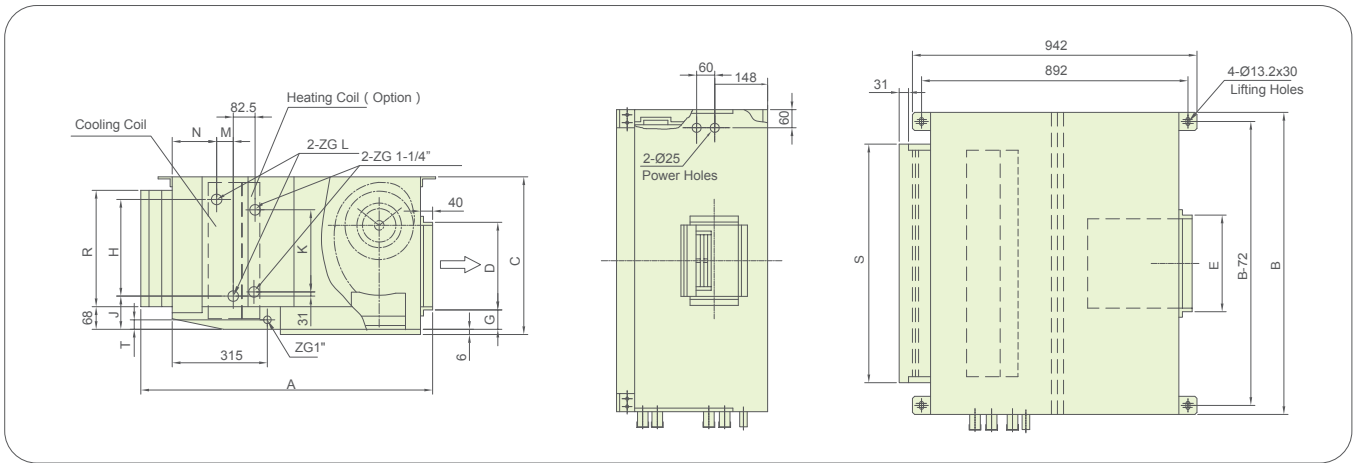

Model	L	W	H	Dimension of outlet			Connection direction and dimension						Dimension of return air inlet		T	
				A	B	C	D	E	G	H	J	K	L			M
											Fresh air	Return air				
DBFP010-3	986	680	380	249	236	39	200	116	114	1-1/4"	1-1/4"	44	158	264	531	34
DBFP010-5																
DBFP015-3	986	875	380	249	236	39	200	116	114	1-1/4"	1-1/4"	44	158	264	726	34
DBFP015-5																
DBFP020-3	986	872	500	225	303	57	320	108	254	1-1/4"	1-1/4"	44	158	385	721	31
DBFP020-5												88	114			
DBFP025-3	986	1018	500	225	303	57	320	108	254	1-1/4"	1-1/4"	44	158	385	869	31
DBFP025-5												88	114			
DBFP030-3	986	1166	500	225	303	57	320	108	254	1-1/4"	1-1/4"	44	158	385	1017	31
DBFP030-5										1-1/2"	1-1/4"	88	114			

## Dimension of DBFP 040~060

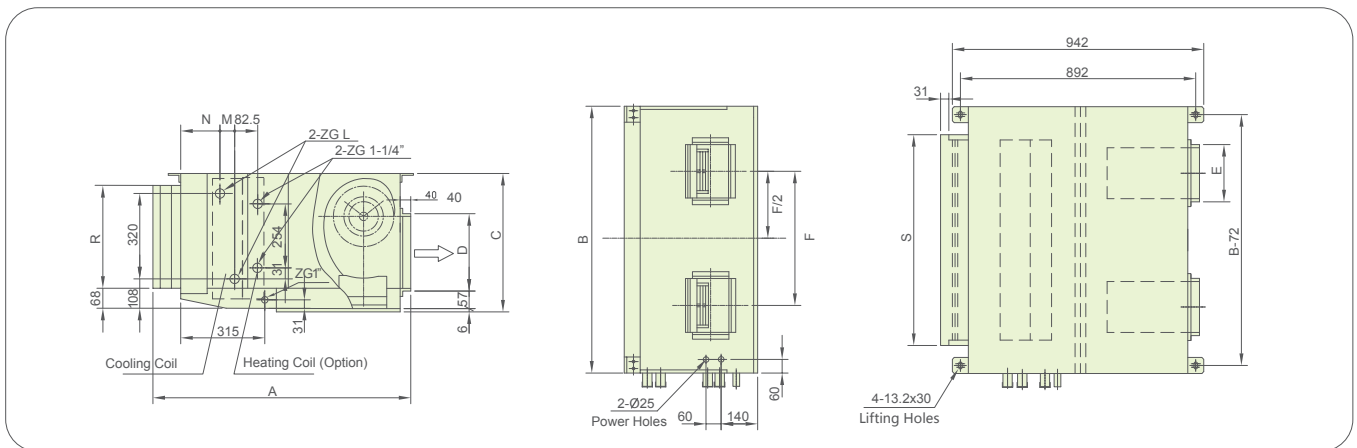

Model	L	W	H	Dimension of outlet			Connection direction and dimension				Dimension of return air inlet				
				A	B	C	D	E	F	L		M	N	R	S
										Fresh air	Return air				
DBFP040-3	986	1458	500	229	303	728	1-1/2"	1-1/4"	44	158	385	1307			
DBFP040-5													88	114	
DBFP050-3	986	1752	500	229	303	875	1-1/2"	1-1/4"	44	158	385	1601			
DBFP050-5													88	114	
DBFP060-3	986	2044	500	229	303	1021	2"	1-1/4"	44	158	385	1893			
DBFP060-5													88	114	726

Note: for DBFP010~060 units, the lug is located on the top of the unit for DBFP080~150 units, the lug is located at the bottom of the unit. When preparing a hanging bar, take into account its length



## Dimension of DBFP 080~100

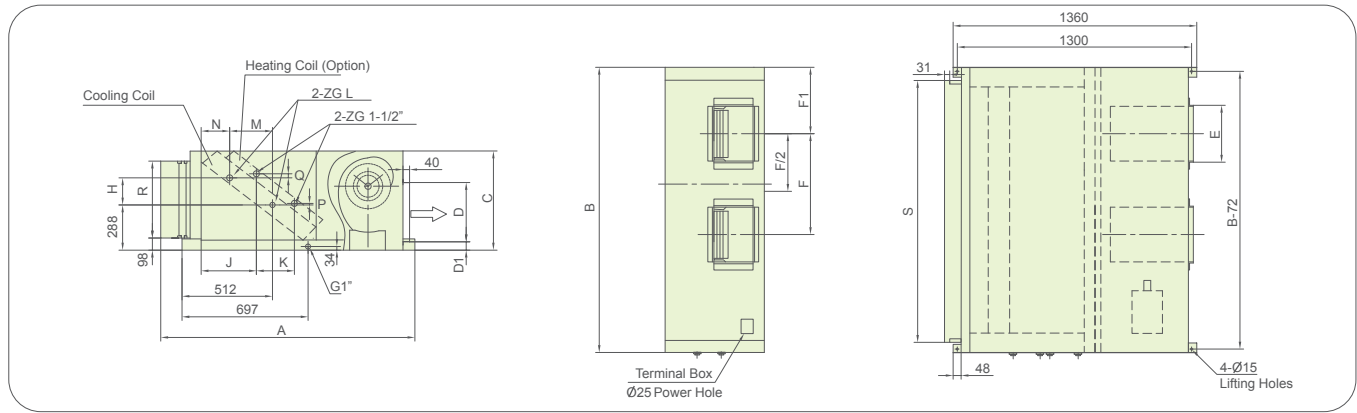

Model	L	W	H	Dimension of outlet					Connection direction and dimension								Dimension of return air inlet				
				A	B	C	D	E	F	F1	D1	H	J	K	L		M	N	P	Q	R
												Fresh air	Return air								
DBFP080-3	1413	1710	595	330	309	553	391	69	105	355	205	2"	2"	241	171	3	58	436	1553		
DBFP080-5	1413	1710	595	330	309	553	391	69	71	344	214	2"	2"	268	139	11	103	436	1553		
DBFP100-3	1413	1970	595	330	395	689	419	69	105	355	205	2"	2"	241	171	3	58	436	1813		
DBFP100-5	1413	1970	595	330	395	689	419	69	71	344	214	2"	2"	268	139	11	103	436	1813		

## Dimension of DBFP 120~150

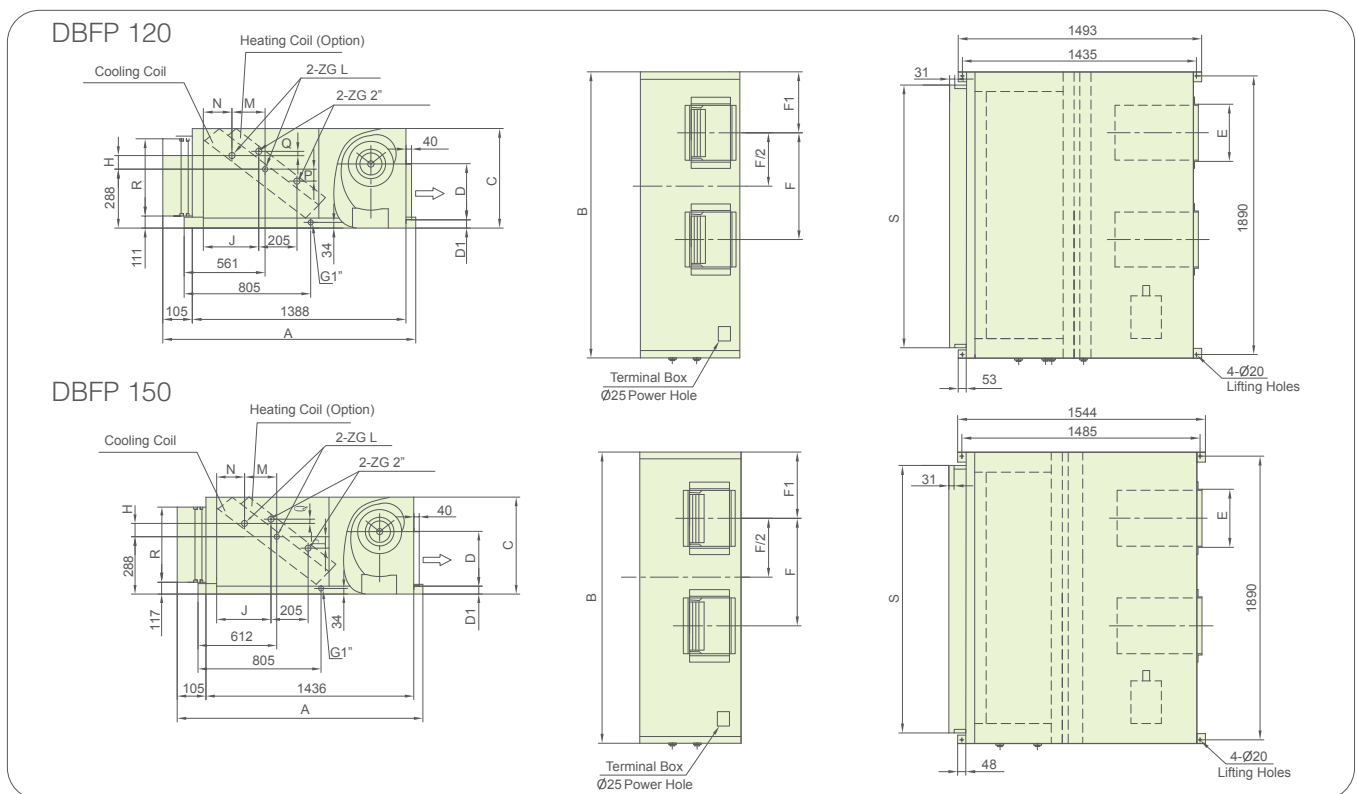

Model	L	W	H	Dimension of outlet					Connection direction and dimension								Dimension of return air inlet				
				A	B	C	D	E	F	F1	D1	H	J	L		M	N	P	Q	R	S
												Fresh air	Return air								
DBFP120-3	1546	1970	675	345	395	689	471	75.5	92	458	2-1/2"	2-1/2"	251	274	1.5	56.5	498	1813			
DBFP120-5	1546	1970	675	345	395	689	471	75.5	70	458	2-1/2"	2-1/2"	268	247	2.5	92.5	498	1813			
DBFP150-3	1595	2060	712	406	445	558	485	67	92	509.5	2-1/2"	2-1/2"	251	326	2.5	57.5	529	1903			
DBFP150-5	1595	2060	712	406	445	558	485	67	70	509.5	2-1/2"	2-1/2"	268	299	2.5	92.5	529	1903			

Note: for DBFP010~060 units, the lug is located on the top of the unit for DBFP080~150 units, the lug is located at the bottom of the unit. When preparing a hanging bar, take into account its length

## DFP Ultrathin Unit

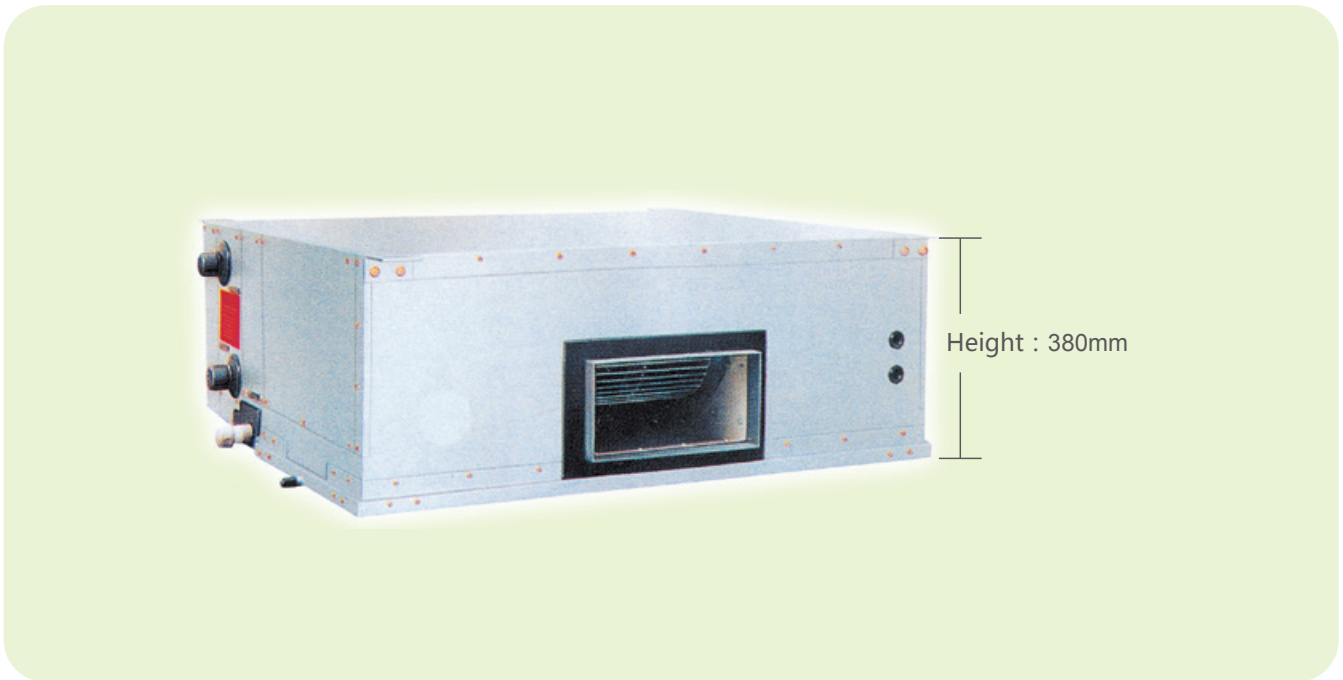

## DFP Technical Data

Model	W×L×H mm	Air flow m³/h	Motor kW-poles	Input power kW	Static pressure Pa	Return air condition						Fresh air condition						Net weight kg
						Cooling Cap. kW	Water flow (cooling) l/s	Water pressure drop (cooling) kPa	Heating Cap. kW	Water flow (heating) l/s	Water pressure drop (heating) kPa	Cooling Cap. kW	Water flow (cooling) l/s	Water pressure drop (cooling) kPa	Heating Cap. kW	Water flow (heating) l/s	Water pressure drop (heating) kPa	
DFP010L	680×986×380	1000	0.18×1	0.4	200	5.0	0.24	10.10	11.0	0.26	11.1	12.6	0.60	53.4	13.2	0.31	14.2	48
DFP010H		1000	0.18×1	0.4	150	6.6	0.31	8.3	12.5	0.30	7.5	15.8	0.76	44.0	15.0	0.36	9.8	50
DFP015L	875×986×380	1500	0.25×1	0.4	185	8.0	0.38	14.5	16.8	0.40	16.7	19.0	0.91	50.4	19.8	0.47	13.3	55
DFP015H		1500	0.25×1	0.4	145	10.1	0.48	10.9	18.7	0.45	9.7	24.0	1.15	57.7	22.6	0.54	12.6	58
DFP020L	1018×986×380	2000	0.32×1	0.58	95	10.6	0.51	21.8	21.9	0.52	23.0	25.0	1.20	58.3	26.9	0.64	18.7	65
DFP020H		2000	0.32×1	0.58	65	12.0	0.57	7.9	24.8	0.59	10.0	30.4	1.45	50.0	29.8	0.71	14.3	67
DFP030L	1458×986×380	3000	0.32×2	1.16	140	16.8	0.80	30.5	33.1	0.79	31.0	38.1	1.82	74.2	40.3	0.96	25.0	92
DFP030H		3000	0.32×2	1.16	110	20.0	0.96	15.3	37.4	0.89	14.3	48.0	2.30	77.5	45.8	1.10	21.5	95
DFP040L	1752×986×380	4000	0.32×2	1.16	85	21.8	1.04	25.5	45.3	1.08	26.6	51.1	2.45	89.7	54.4	1.30	29.3	105
DFP040H		4000	0.32×2	1.16	55	27.4	1.31	25.3	52.3	1.25	24.9	62.9	3.01	89.9	61.1	1.46	34.9	109

### Standard Air Conditions:

Cooling: Entering Water 7 C, Temperature Rise 5 C, Entering Air DB 27 C, WB 19.5 C.

Heating: Entering Water 60 C, Leaving Water 50 C, Entering Air DB 15 C.

### Fresh Air Conditions:

Cooling: Entering Water 7 C, Temperature Rise 5 C, Entering Air DB 35 C, WB 28 C.

Heating: Entering Water 60 C, Leaving Water 50 C, Entering Air DB 7 C.

### Note:

1. Model with L means rated cooling capacity unit, model with H means high cooling capacity unit.

2. Motor input power refers to total motor input power.

3. Static pressure data in the from are for units with standard configuration (w/o heating coil or wet film). Static pressure data should reduce 50Pa with wet film humidifier, and should reduce

pressure drop if add heating coil (Pressure drop of heating coil please refer ""2R Heating coil performance data""

4. No control options for DFP.

## Dimension of DFP

- Each model of unit has the same top views and sizes.
- ZG1" is drain pan connection. For method of installation, see the Manual for Installation, Operation and Maintenance.

Model	Size			
	A	B	C	D
DFP010L	680	531	608	164
DFP010H				
DFP015L	875	726	803	164
DFP015H				
DFP020L	1018	869	946	156
DFP020H				

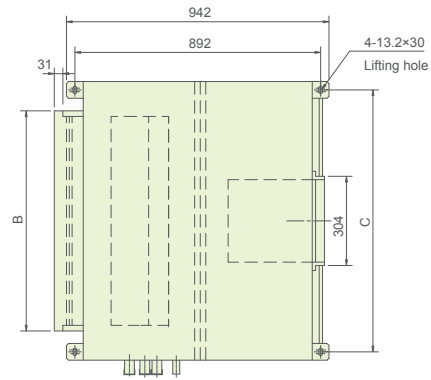
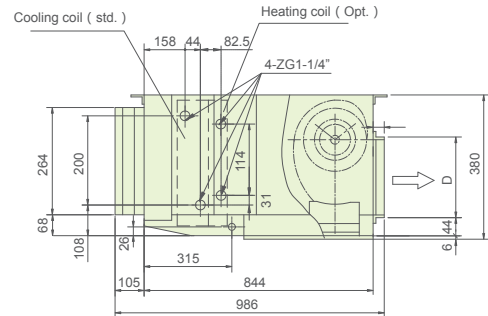
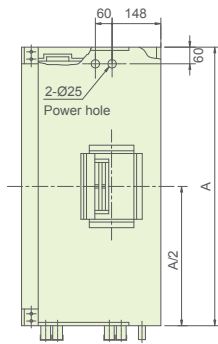

Model	Size						
	A	B	C	D	E	F	G
DFP030L	1458	1307	1386	728	1-1/4"	44	158
DFP030H							
DFP040L	1752	1601	1680	875	1-1/4"	44	158
DFP040H							

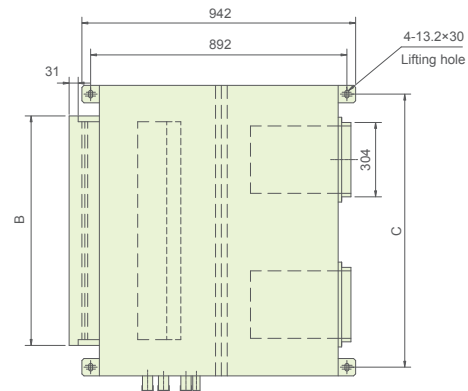
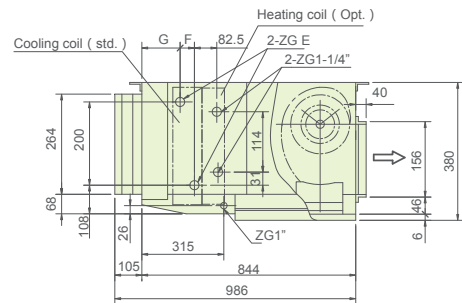
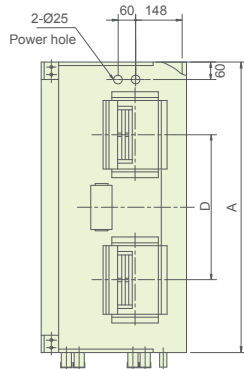

## 2R Heating coil performance data (Option)

Model	Air volumn m <sup>3</sup> /h	Return air condition				Fresh air condition			
		Heating Cap. kW	Water flow l/m	Water pressure drop kPa	Air pressure drop Pa	Heating Cap. kW	Water flow l/m	Water pressure drop kPa	Air pressure drop Pa
DBFP010	1000	4.8	0.11	1.0	10	5.8	0.14	1.0	10
DBFP015	1500	7.5	0.18	1.0	10	9.0	0.22	1.0	10
DBFP020	2000	10.0	0.24	1.0	10	12.0	0.29	1.0	10
DBFP025	2500	12.6	0.3	1.0	10	15.2	0.36	1.0	10
DBFP030	3000	15.4	0.37	1.0	10	18.4	0.44	1.0	10
DBFP040	4000	20.6	0.5	2.0	10	24.8	0.60	2.8	10
DBFP050	5000	25.9	0.62	3.9	10	31.2	0.75	5.7	10
DBFP060	6000	31.3	0.75	6.9	10	37.7	0.90	10.0	10
DBFP080	8000	38.7	0.93	5.8	15	46.9	1.12	8.3	15
DBFP100	10000	47.7	1.14	10.2	15	57.1	1.37	14.8	15
DBFP120	12000	63.5	1.52	9.3	15	76.7	1.83	13.5	15
DBFP150	15000	79.9	1.91	11.9	15	96.4	2.30	17.1	15
DFP010	1000	4.8	0.11	1.0	10	5.8	0.14	1.0	10
DFP015	1500	7.5	0.18	1.0	10	9.0	0.22	1.0	10
DFP020	2000	9.9	0.24	1.0	10	11.9	0.29	1.0	10
DFP030	3000	15.5	0.37	1.0	10	18.6	0.45	1.0	10
DFP040	4000	20.3	0.49	1.0	10	24.6	0.59	1.0	10

Return air condition: Entering air temp. 15 °C DB, Inlet water temp.60 °C , Outlet water temp.50 °C  
 Fresh air condition: Entering air temp. 7 °C DB, Inlet water temp.60 °C , Outlet water temp.50 °C

## Technical data of wet film humidifier (option)

Model	Air volumn m <sup>3</sup> /h	Air pressure drop Pa	Thickness of wet film humidifier mm	Maxim humidification kg/h
DBFP010	1000	50	50	1.72
DBFP015	1500	50	50	2.68
DBFP020	2000	50	50	3.79
DBFP025	2500	50	50	4.81
DBFP030	3000	50	50	5.82
DBFP040	4000	50	50	7.86
DBFP050	5000	50	50	9.89
DBFP060	6000	50	50	12.11
DFP010	1000	50	50	1.72
DFP015	1500	50	50	2.68
DFP020	2000	50	50	3.79
DFP030	3000	50	50	5.82
DFP040	4000	50	50	7.86

Note:

1. Air inlet condition : DB36°C , 10%RH

2. If wet film humidifier selected, please take away the pressure drop of humidifier for external and total static pressure drop.

## Wiring Diagram of Unit (DBFP 010~060)

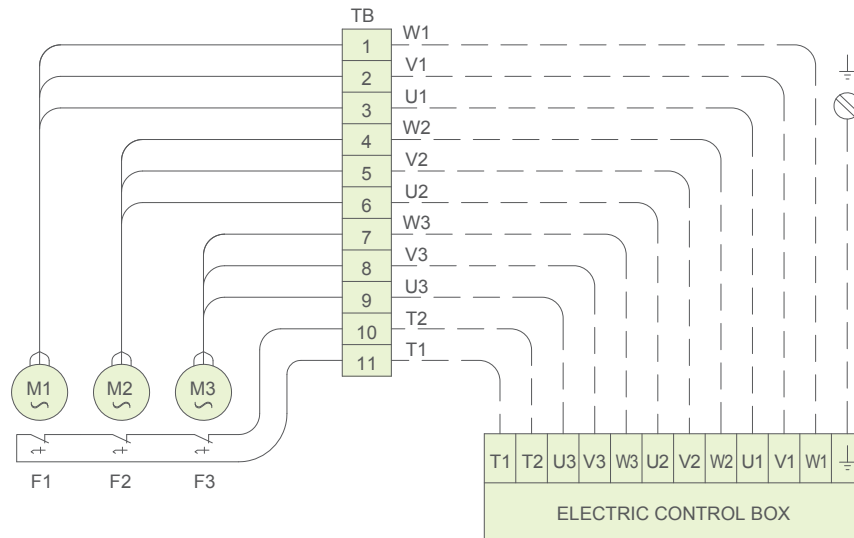

- 1)TB--terminal Block
- 2)Electric control Box is the optional accessory
- 3)M1,M2,M3--Three phases external-rotor motor
- 4)F1,F2,F3--motor overheat protector
- 5)-----Customer Wiring
- 6)-----Factory Wiring
- 7)If motor has overheat protector: Three motor--wiring follow the wiring diagram.  
Two motor--wiring 1~6 and T1,T2 one motor--wiring 1~3 and T1,T2phase connect T1,T2into motor control circuit.
- 8)If motor has not overheat protector: Three motor--wiring 1~9.  
Two motor--wiring 1~6,One motor--wiring1~3

## Wiring Diagram of Unit (DBFP 080~150)

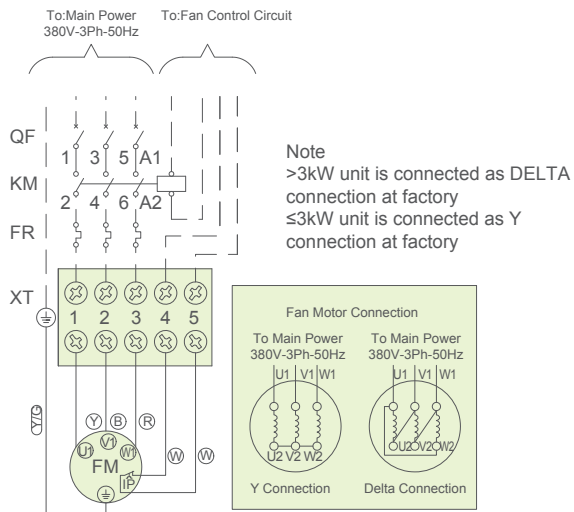

### LEGEND

- Factory wiring
- Wiring by installer
- QF Circuit breaker (User option)
- KM Fan contactor (User option)
- M Fan motor
- FR Overload relay (User option)
- XT Terminal block

### WIRE COLORS

- ⓐ Green
- ⓑ Red
- ⓒ Yellow
- ⓓ White
- ⓔ Yellow/Green

### ATTENTION

Any warranty is declined in case of field changes of factory wiring and settings

## Instruction

1. The application pressure of the surface cooler and the hot water heater should not exceed 1.6MPa. Use pipe thread (wrapped with raw material band) or flange to connect the water inlet pipe and the water outlet pipe. The connection type of the water pipe is “down inlet, up outlet”.
2. In consideration of the negative pressure, U water seal must be installed on each condensate drain pipe to connect the sewer. To make the condensate water discharged without obstruction, the drain pipe should have the gradient of slope 1/25 – 1/50.

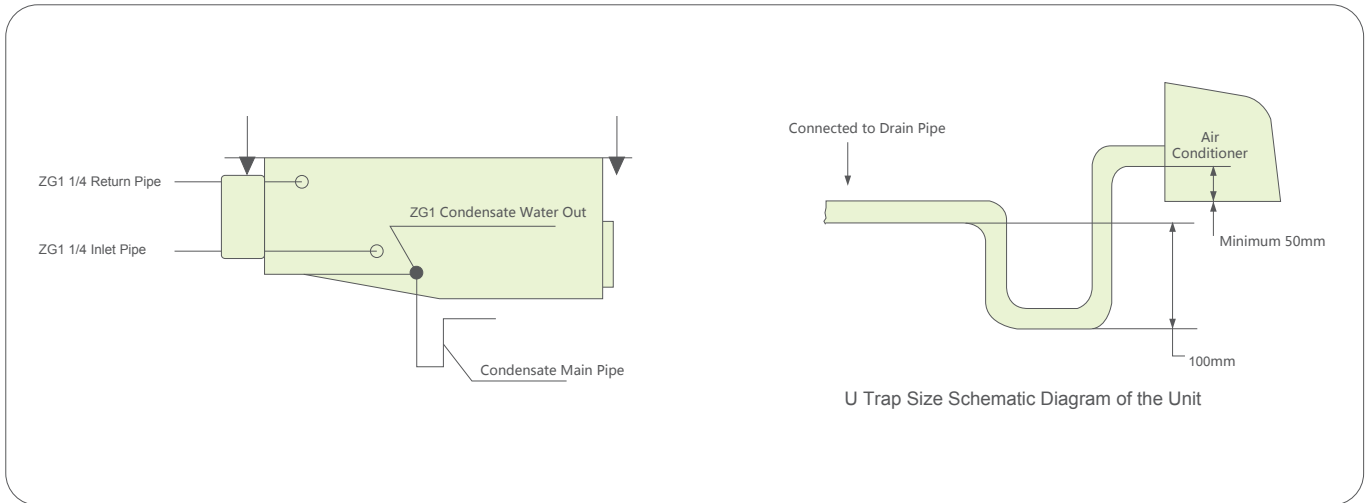

3. Preheat device should be installed in the inlet of fresh air unit, to protect coil from freezing operation with fresh air temperature below 0°C.
4. The unit supply air temperature should be no more than 80°C (heating). If it is, please give us clear indication, we can adopt high temperature bearing special motor.
5. The fan outlet and discharge should be connected with soft connection.
6. The water in the coil should be drawn off completely when the unit is stopped and below freezing temperature. Antifreeze shall be poured into pipe if remaining water cannot be drawn off completely.





Carrier improves the world around us; Carrier improves people's lives; our products and services improve building performance; our culture of improvement will not allow us to rest when it comes to the environment.



[www.carrier.com](http://www.carrier.com)

The Manufacturer reserves the right to change any product specifications without prior notices  
© All Rights Reserved Carrier

Version:	CAT_DBFP_E-2001-08
Supersede:	CAT_DBFP_E-1904-07
Effective Date:	Jan, 2020