



**AQUAEDGE™**

# 19XR Centrifugal Liquid Chiller

Cooling Capacity: 300~3400RT  
1000~6800RT (series counter flow system)





In 1998, Time magazine named Dr. Carrier one of its 20 most influential builders and titans of the 20th century.

Carrier is a leading global provider of innovative HVAC, refrigeration, fire, security and building automation technologies. Supported by the iconic Carrier name, the company's portfolio includes industry-leading brands such as Carrier, Kidde, Edwards, LenelS2 and Automated Logic. Carrier's businesses enable modern life, delivering efficiency, safety, security, comfort, productivity

and sustainability across a wide range of residential, commercial and industrial applications.



## Model Number Nomenclature

### 19XR/XR-C/E/F

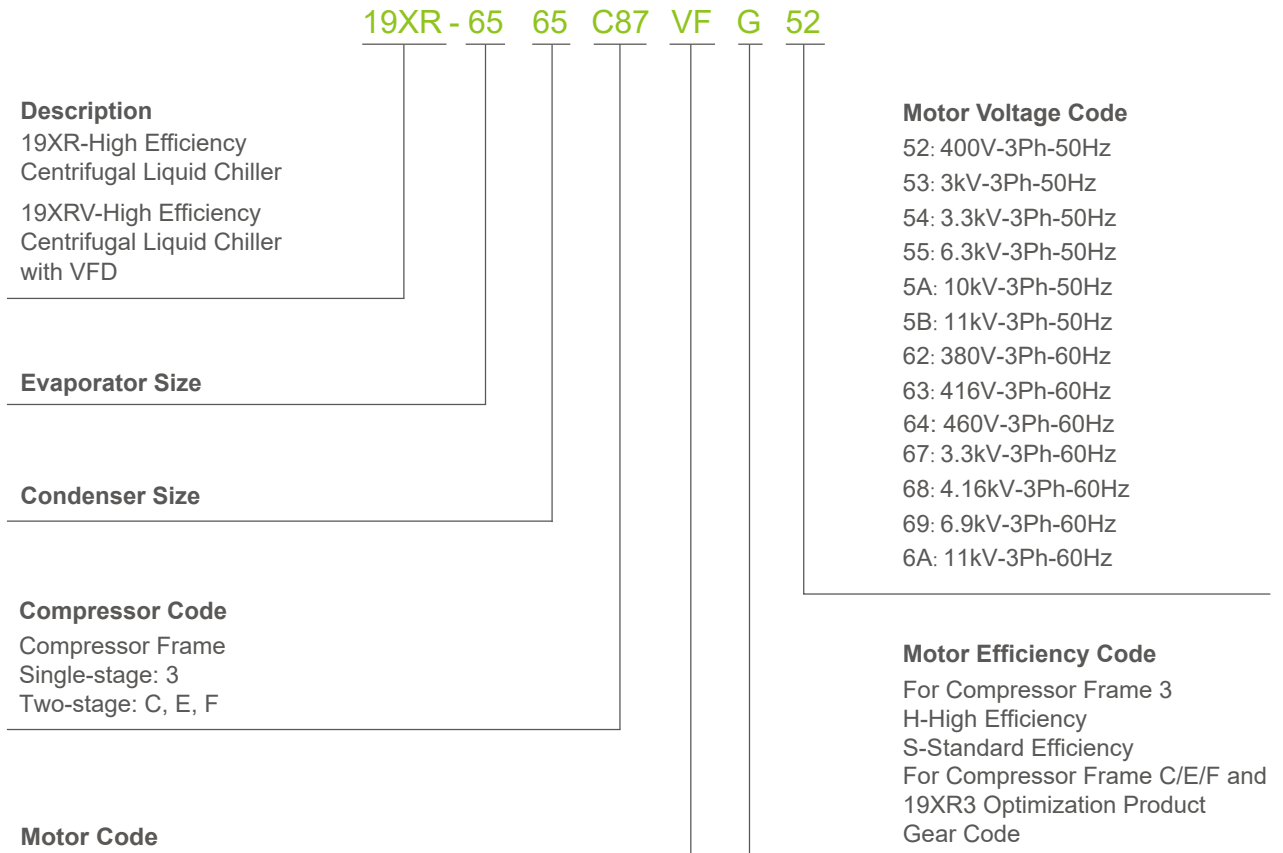

### 19XR-6/7

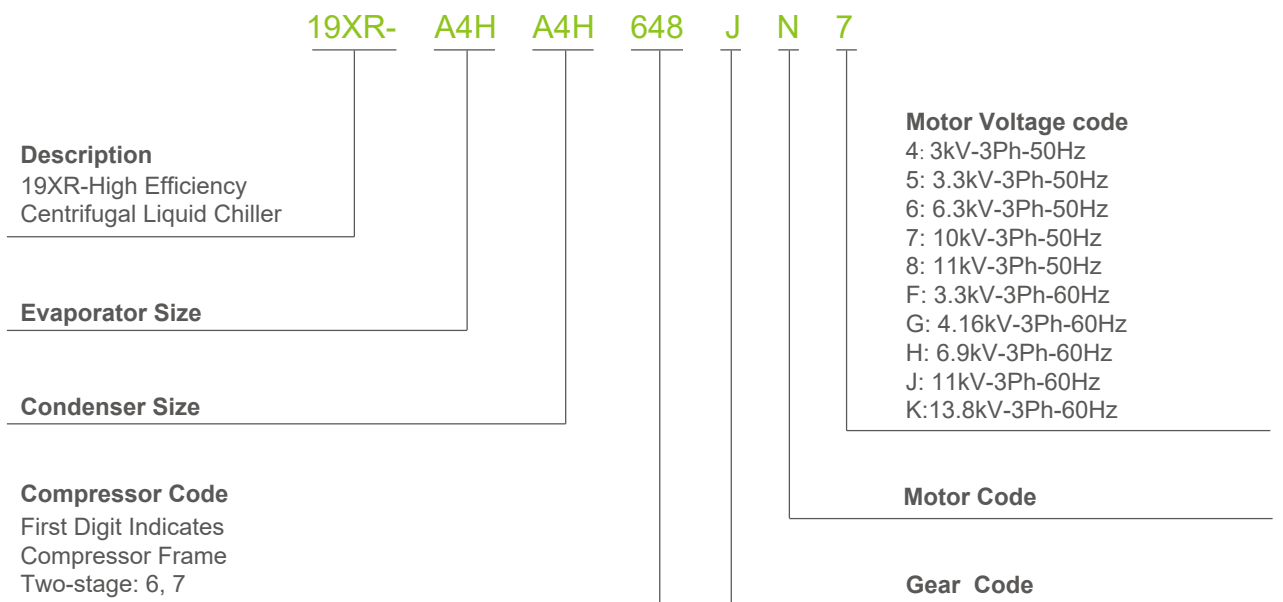

## Energy-saving and High Efficiency

- Taper pipe diffuser is applied in single stage compressor to improve compressor efficiency.
- Vaneless diffuser designed for two-stage compressor, combined with inner-stage economizer improves chiller performance and makes it a better choice of high lift application.
- High performance tubing - Tubing with internally and externally enhanced fins improves chiller performance by reducing overall resistance to heat transfer. The new heat exchanger reduces refrigerant charge and manufacturing cost.
- Carrier AccuMeter system regulates refrigerant flow according to load conditions, provides a liquid seal at all operating conditions and eliminates unintentional hot gas bypass. Thus ensure the part load performance of chiller.

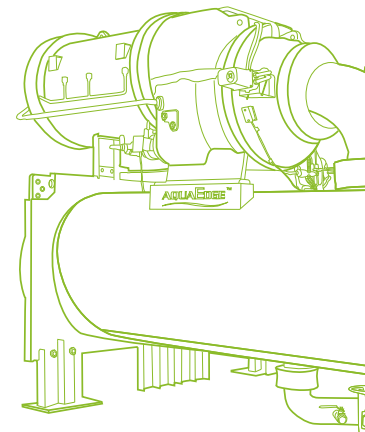
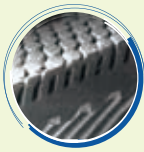

## Stable Operation

- Variable inlet guide vanes - The guide vanes are controlled by a precise electronic actuator. The vanes regulate inlet flow to provide high efficiency through a wide operating range.
- Diffuser design - Pipe diffuser design uses jet engine technology, increasing centrifugal compressor peak efficiency (single-stage only). Two-stage compressor utilizes vaneless diffuser to meet high lift application requirement with stable operation.
- Semi-hermetic Motors - Cooling is accomplished by spraying liquid refrigerant on the motor windings. This highly efficient motor cooling method also eliminates the potential for shaft seal leaks and refrigerant/oil loss.

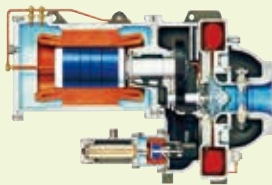

## Environmental Sustainability

- Designed for chlorine-free R-134a refrigerant, A1 class in ASHRAE 34 safety standard and R-513A or R-515B refrigerant with low global warming potential can be offered as option.



## Flexible Combination

- 19XR/XR(V) AquaEdge chiller provides a complete line of compressors, motors and heat exchangers, ensuring good combination of chiller components regardless of tonnage, lift, and efficiency specifications.
- Carrier offers multiple starters choices for different power supply application.
- 19XR(V) AquaEdge chiller can be equipped with high tier LF2 VFD which with Active Rectifier, the harmonic distortion (THD)  $\leq 5\%$ , fully comply IEEE519-1992 requirement, also the fundamental power factor can be up to 0.99. With the help of VFD, the IPLV.IP of 19XR(V) can achieve to 11.0.
- Colorful Touch Screen - friendly human machine interface, graphical display screens for the main components and support multi languages.

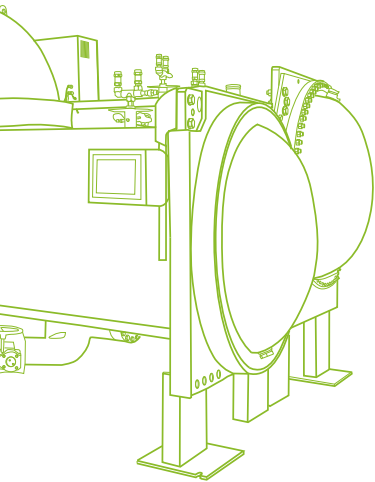

Free-standing VFD starter



Unit-mounted VFD starter

## Convenient Installation

- Water boxes are equipped with standard flanges, which provides the ease of field piping.
- Positive pressure design can save valuable mechanical room space with reducing 35% chiller size compared with low pressure design. In addition, it eliminates the need for purge system to save the cost for customer.
- Refrigerant-cooled oil cooler, no need for field water piping, reduce installation cost.
- Cooler and condenser are designed and manufactured in accordance with relevant GB code.
- The unit isolation valves facilitate the condenser as a liquid container during the transition season, which provides ease of maintenance.

# Carrier® SmartVu™ Intelligent Control System

## User-friendly Interface

Carrier centrifugal chiller equips the latest Carrier® SmartVu™ control system with strong control and detecting function during chiller operation. The control system applies a 10 inch colorful touch screen, which can support up to ten language choices for customer, real time display of operation parameters with pictures makes it more human friendly and comfortable interface for operation. Carrier® SmartVu™ intelligent control system simulates and detects chiller operation, adjusts cooling or heating capacity according to load change and provides various protection during operation.

## Smart Operation

- Carrier® SmartVu™ control system provides smart password function to avoid any setting change without authorization.
- When chiller receives start-up order, controller will conduct following pre-start safety checking, to ensure parameters like oil sump temperature, condensing pressure, bearing temperature, motor winding temperature, discharge temperature, evaporator saturated temperature and average line voltage etc. are normal.
- During chiller operation, except for the function of detecting main operation parameters control system also has capability to record and display trend curve, which is real time trend of key components during operation. It ensures effective and reliable operation of chiller by optimized intelligent and dynamic control algorithm.
- Carrier® SmartVu™ control system has comprehensive protection during operation, such as oil sump temperature control, surge protection, overvoltage and overcurrent protection, discharge temperature overheat protection, bearing temperature overheat protection, evaporator and condenser anti-freeze protection, low discharge superheat protection etc. in order to ensure chiller long time reliable operation.
- The optional Envelope Stability Control is an advanced solution to balance the chiller efficiency and reliability at very low load. The controller optimizes compressor speed, inlet guide vane position and stabilizer valve position to find the most efficient operating point throughout the operating range without compromising the chiller stability in real time.

## Intelligent Diagnosis

- Carrier® SmartVu™ control system has failure diagnostic function and can be easily accessed via touch screen for detail chiller operation parameters. If control system detects failure the alarm will be initiated and related code will be recorded in alarm menu. The alarm records can be automatically saved by control system. Carrier service technician can read and delete alarm records by Carrier service tools.
- The control system has additional pre-diagnostic function. Different with diagnostic function, information displayed from this function is mainly for maintenance purpose. For an example, to inform customer periodically replace lubricant and filter from this function.
- Carrier® SmartVu™ control system has email alarm function. If the controller has been connected to internet, the control system can automatically send out an email with one or more alarm information to customer or service people through effective email address when alarm occurs.

## Flexible Interface and Easy Connection with Building Automation System

- Carrier® SmartVu™ control panel supports BACnet or Modbus protocol, with which chiller can seamlessly connect with the Building Automation System or the i-Vu™/WebCTRL™ control network.
- With the powerful i-Vu™ Link (optional), user can integrate all plant equipment into i-Vu™ Building Automation System. The i-Vu™ Building Automation System provides everything user needs to access, manage, and control your building, including the powerful i-Vu™ user interface, plug-and-play BACnet or Modbus controllers and state-of-the-art Carrier equipment.
- Carrier provides WebCTRL™ as an additional option to provide similar function like i-Vu™ Link. If you have any questions, please contact with Carrier local agents.

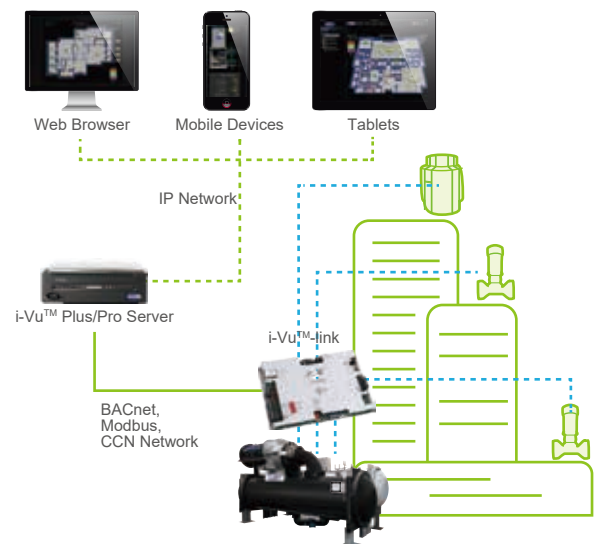

The i-Vu™ Building Automation System

## Smart Chiller

Using wireless cellular communications technologies, Carrier SMART Service continuously streams operating data to the cloud in real time directly from your chiller's controller. The data is then captured within our IoT platform for ongoing insight into your chiller's health.

Features:

- ✔ Integrated equipment sensors that capture key operating data
- ✔ Secure wireless connectivity to Carrier's cloud-based IoT platform
- ✔ Persistent and reliable data transmission



## Smart Cloud

Carrier SMART Service continuously stores and assesses equipment operating data and service history, comparing it to established values for analytics and data validation. It compares this data to design specifications and matches it against allowable ranges, allowing Carrier to deliver pre-emptive service solutions as needed.



Features:

- ✔ Complete visibility into your system's performance, energy usage and service history
- ✔ Advanced diagnostics and analytics providing actionable insights

## Smart Technician



Carrier SMART Service changes how equipment is serviced and maintained. Carrier service technicians now utilize mobile devices with access to put real-time chiller data and service history in the palm of their hands. With advance notification of problems, technicians arrive at the jobsite more informed, which leads to faster problem resolution and reduced mean time to repair.

Features:

- ✔ Advance notification
- ✔ Remote detection and diagnosis

## 19XR Two-stage Centrifugal Chiller

In 2013, Carrier introduced a high-efficiency two-stage centrifugal chiller to deliver energy saving and environmental sustainability, as well as comprehensive range of air-conditioning, heat pump, energy recovery, ice thermal storage, VFD and high-voltage applications.

### Environmental Sustainability

Designed for chlorine-free R-134a refrigerant, A1 class in ASHRAE 34 safety standard and R-513A or R-515B refrigerant with low global warming potential can be offered as option.



### Industry-leading Efficiency

19XR chillers can achieve up to 6.6 full load COP<sub>R</sub> and 7.5 IPLV.IP (without VFD) or 11.0 IPLV.IP (with VFD) at AHRI conditions.

- Advanced high efficiency two-stage compressor.
- New blunt leading-edge IGV for part load efficiency improvement.
- An interstage economizer improves system efficiency and increases capacity.

### Wide Application

The innovative two-stage compressor provides a wide range of capabilities. With a maximum LWT of 65°C and a minimum LCWT of -6°C, the 19XR two-stage centrifugal chiller is ideal wherever energy conservation and environmental stewardship are required.

### Stable Operation

The two-stage compressor has very good load-adjustment capabilities to achieve high efficiency and stability at a variety of load and temperature conditions, including its minimum load of 10%.

The 19XR two-stage centrifugal chiller also features a refrigerant cooled semi-hermetic low current inrush motor, eliminating the need for shaft seal and oil refrigerant containment components.

Double-grooved tube sheets make a superior leak-tight joint when combined with roller expansion.

### Low Sound Level

For ultra-quiet operation, the advanced two-stage compressor has an optimized aero-structural design and allows lower impeller speed.

### Modular Construction

The cooler, condenser and compressor assemblies are compact and entirely bolted together. This design makes the chiller ideally suited for replacement projects where ease of disassembly and reassembly at the jobsite is essential.

## Series Counter Flow Application

Carrier 19XR centrifugal chillers fully support system application of Series Counter Flow with cooling capacity of each system up to 6800 Tons.

### Better System Efficiency

- Improved full load efficiency by reducing the lift of each circuit cycle.
- Optimized part load operation to achieve better system efficiency at duties less than 50%.

### Better Reliability and Redundancy

- Two independent refrigeration circuits and either compressor can be configured as lead.
- Two compressors start-up orderly to reduce system inrush current.
- Two compressors operate in turn to balance operation time and enlarge service interval.

### Advanced System Control (Standard in Carrier® SmartVu™)

- Optimized load balance by recalculating upstream chiller control point.
- Optimized surge control by synchronizing surge condition of both lead and lag chiller.
- Optimized lead/lag communications.

Two chiller modules of SCF system may be arranged in side-by-side or series depending on chiller plant layout. Details please contact Carrier local agencies.

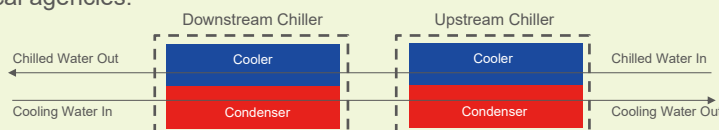



## Heat Pump Application

The heat pump system utilizes natural energy storage in soil, bedrock, groundwater, surface water, wastewater and air to satisfy demand for building cooling, heating and hot water.

### Heat Pump System Benefits

- ✔ Cooling/heating
- ✔ Improved system efficiency
- ✔ Use of low-grade energy

### 19XR-E/6/7 Benefits

- ✔ Wide range of applications with high efficiency
- ✔ Hot water temperature (LWT) up to 65°C

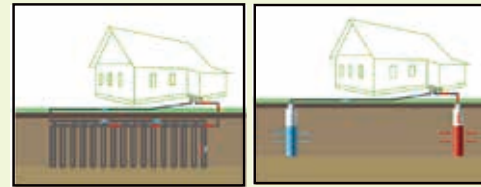

Geothermal

Underground water

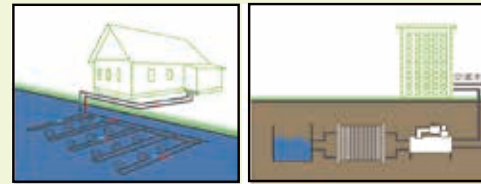

Earth's surface water

Dark/Grey water

## Energy Recovery Application

Discharging condenser heat via a cooling tower not only causes thermal pollution but also brings tremendous energy waste to the applications such as hotel, factory and hospital.

### Energy Recovery System Benefits

- ✔ Reduced boiler size and operating time
- ✔ Reduced cooling tower size and waste heat discharge
- ✔ Improved system efficiency by 15-25%

### 19XR Benefits

- ✔ High efficiency operation
- ✔ Energy saving up to 70% versus boiler

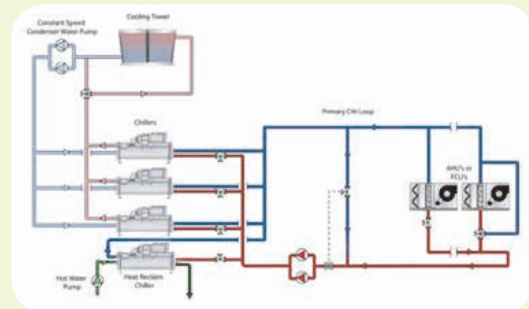

## Ice Thermal Storage Application

The chiller stores energy as ice during night, when electricity costs and utilization are low. The energy is discharged to meet cooling loads during day time when the electricity price is high, greatly reducing building operating costs.

### Ice Thermal Storage System Benefits

- ✔ Reduced chiller and cooling tower size
- ✔ Reduced chiller operating time
- ✔ Operational cost savings by using off-peak electricity
- ✔ Backup cooling in emergency situations

### 19XR-E/6/7 Benefits

- ✔ Stable 24-hour operation
- ✔ Suitable for variable voltage and VFD applications
- ✔ Minimum leaving water temp (LCWT): -6°C
- ✔ Suitable for low temperature air distribution and district cooling systems

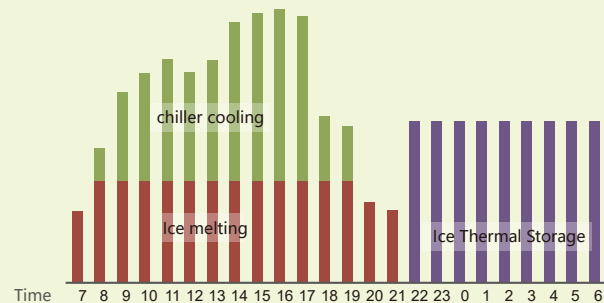

## Performance Data

### Air-conditioning (380V-3Ph-50Hz)

Model	Chiller				Motor		Evaporator			Condenser			Weight		
	Cooling Capacity		Input Power	Full load COP <sub>R</sub>	RLA	LRYA	Flow Rate	Pressure Drop	Water Connection	Flow Rate	Pressure Drop	Water Connection	Operating	Rigging (w/o Refrigerant)	Refrigerant Charge
	kW	Tons	kW	ikW/kW	A	A	l/s	kPa	mm	l/s	kPa	mm	kg	kg	kg
19XR-313234HUEU52	1407	400	253.1	0.180	435.8	1046	67.20	107	DN200	79.90	77.8	DN200	6965	6046	396
19XR-404035HUFT52	1583	450	288.4	0.182	496.2	1119	75.60	77.9		90.10	70.8		8097	6808	483
19XR-414138HUGU52	1758	500	310.0	0.176	525.4	1176	84.00	78.1		99.60	70.0		8386	7004	508
19XR-505138HUGT52	1934	550	337.5	0.175	569.3	1176	92.40	71.3		109.4	46.6	DN250	9488	7788	609
19XR-5051C37VCE52	2110	600	357.5	0.169	611.5	1143	100.8	83.5		118.6	54.0		11227	9432	704
19XR-5P50C39VEG52	2286	650	407.7	0.178	708.7	1556	109.2	79.7		129.3	73.4		10865	9217	588
19XR-5052C35VDG52	2286	650	386.7	0.169	668.5	1457	109.2	96.6		128.5	55.1		11382	9553	704
19XR-5P50C49VEG52	2462	700	434.7	0.177	750.4	1556	117.6	91.4		139.0	83.8		10865	9217	588
19XR-5151C45VEG52	2462	700	413.0	0.168	717.0	1556	117.6	92.7		138.1	71.4		11474	9602	739
19XR-5P51C49VFJ52	2638	750	466.8	0.177	804.3	1570	126.0	104		149.0	82.0		11035	9351	588
19XR-5252C69VEE52	2638	750	438.5	0.166	756.3	1556	126.0	95.3		147.8	71.2		11711	9759	761
19XR-5R52C49VGJ52	2813	800	493.4	0.175	849.6	1845	134.4	98.0		158.8	81.2	11371	9579	619	
19XR-6X65C65VFG52	2813	800	468.9	0.167	807.6	1570	134.4	86.9		DN250	157.8	79.3	12810	10677	714
19XR-6Z67C87VGG52	3165	900	522.5	0.165	895.3	1845	151.2	90.2			177.3	80.0	13334	11034	752
19XR-6Z69C09VHG52	3517	1000	587.6	0.167	988.6	2083	168.1	109		197.4	90.3	13441	11108	752	
19XR-7Q72C09VHJ52	3869	1100	649.4	0.168	1088.6	2083	184.9	89.5		DN300	217.2	76.3	DN300	17215	14095
19XR-7Q72E53MEB52	4220	1200	735.8	0.174	1249.9	2729	201.7	105	238.0		90.4	18522		15344	1046
19XR-8P81E51MEB52	4220	1200	697.0	0.165	1186.5	2729	201.7	72.6	DN350	236.3	69.2	DN350	21060	17195	1156
19XR-8P80E63MFB52	4572	1300	799.1	0.175	1358.4	3276	218.5	84.0		257.8	92.4		20861	17071	1156
19XR-8Q81E61MFB52	4572	1300	766.0	0.168	1304.2	3276	218.5	72.6		256.4	80.3		21404	17418	1200
19XR-8282E63MFB52	4924	1400	828.2	0.168	1405.8	3276	235.3	98.9		276.3	82.1		22435	18145	1426
19XR-8R84E63MFB52	5275	1500	909.6	0.172	1537.8	3276	252.1	83.4		297.1	76.7		22421	18083	1247
19XR-8484E63MFB52	5275	1500	885.0	0.168	1498.0	3276	252.1	104		296.0	76.2		22997	18549	1386

### Brine application (10kV-3Ph-50Hz)

Model	Chiller				Motor		Evaporator			Condenser			Unit Dimensions			Weight		
	Cooling Capacity		Input Power	Full Load Efficiency	RLA	LRYA	Flow Rate	Pressure Drop	Water Connection	Flow Rate	Pressure Drop	Water Connection	Length	Width	Height	Operating	Rigging(w/o Refrigerant)	Refrigerant Charge
	kW	Tons	kW	ikW/kW	A	A	l/s	kPa	mm	l/s	kPa	mm	mm	mm	mm	kg	kg	kg
19XR-7072E45MDE5A	2462	700	599.8	0.244	41.2	221	158.0	129	DN300	210.2	72.4	DN300	5045	2426	2889	19307	16050	1192
19XR-7R74E55MFE5A	2813	800	696.6	0.248	47.3	235	180.6	95.6		240.8	87.8		5045	2426	2889	19302	15990	1082
19XR-8R84E65MFE5A	3165	900	776.7	0.245	52.9	235	203.2	72.4	DN350	270.5	65.0	DN350	5121	2711	2937	22794	18456	1247
19XR-8787E65MFE5A	3517	1000	835.3	0.238	57.0	235	225.8	135		298.6	105		5731	2711	2937	24501	19784	1592

- Note:**
- The above selections are based on entering/leaving chilled water temperature:12/7°C; entering/leaving cooled water temperature:32/37°C. Cooler fouling factor is 0.0176 m<sup>2</sup>C/kW and condenser fouling factor is 0.044 m<sup>2</sup>C/kW.
  - The above brine application selections are based on entering/leaving chilled water temperature:-2/-6°C; entering/leaving cooled water temperature:30/33.5°C. Cooler fouling factor is 0.0176 m<sup>2</sup>C/kW and condenser fouling factor is 0.044 m<sup>2</sup>C/kW, 25% ethylene glycol.
  - Carrier will select specific models using computer on different requests for tonnage, lift, and efficiency. For details, please contact local agencies.
  - Standard water box pressure is 1.0MPa, and can provide 1.6MPa, 2.0MPa as option; For more requirements, please contact local agencies.
  - The above selections are made based on the voltage being 380V/10kV. For details or customized selections, please contact local agencies.
  - 60Hz selections are also available. Please contact local agencies to get more support.

# Performance Data

## Air-conditioning (10kV-3Ph-50Hz)

Model	Chiller				Motor		Evaporator			Condenser			Weight			
	Cooling Capacity		Input Power	Full load COP <sub>r</sub>	RLA	LRYA	Flow Rate	Pressure Drop	Water Connection	Flow Rate	Pressure Drop	Water Connection	Operating	Rigging (w/o Refrigerant)	Refrigerant Charge	
	kW	Tons	kW	ikW/kW	A	A	l/s	kPa	mm	l/s	kPa	mm	kg	kg	kg	
19XR-6Y69C89LHG5A	3165	900	530.3	0.168	36.5	200	151.2	98.8	DN250	177.7	74.5	DN250	14037	11750	735	
19XR-7P72C09LHG5A	3517	1000	588.2	0.167	40.0	200	168.1	89.7	DN300	197.4	64.0	DN300	17669	14654	949	
19XR-7P71E53MDB5A	3869	1100	680.2	0.176	45.3	221	184.9	107		218.4	88.5		18549	15546	1007	
19XR-7171E51MDB5A	3869	1100	636.2	0.164	42.4	221	184.9	106		216.4	86.9		19367	16050	1251	
19XR-7Q72E53MFB5A	4220	1200	733.6	0.174	48.4	235	201.7	105		237.9	90.3		18960	15782	1046	
19XR-8P81E51MFB5A	4220	1200	695.3	0.165	45.8	235	201.7	72.6	DN350	236.2	69.1	DN350	21498	17633	1156	
19XR-8P80E63MFB5A	4572	1300	797.2	0.174	52.7	235	218.5	84.0		257.7	92.3		21234	17444	1156	
19XR-8Q82E61MFB5A	4572	1300	758.7	0.166	50.1	235	218.5	72.6		256.2	71.4		22041	17980	1200	
19XR-8P81E63MFB5A	4924	1400	860.3	0.175	57.1	235	235.3	96.2		277.6	93.0		21498	17633	1156	
19XR-8282E63MFB5A	4924	1400	826.3	0.168	54.7	235	235.3	98.9	DN400	276.2	82.1	DN400	22808	18518	1426	
19XR-8R84E63MFB5A	5275	1500	907.6	0.172	60.3	235	252.1	83.4		297.1	76.7		22794	18456	1247	
19XR-8QV4F30MFT5A	5275	1500	882.1	0.167	57.9	285	252.1	82.3		296.1	66.3		DN450	24160	19833	1098
19XR-8QV4F40WHT5A	5627	1600	927.8	0.165	60.0	409	268.9	93.2		315.1	74.3			24428	20102	1098
19XR-8RV4F40WJT5A	5979	1700	985.4	0.165	64.3	479	285.7	90.7	334.7	83.0	24801	20358		1141		
19XR-8ZV8F50WJT5A	6330	1800	1048	0.166	68.3	479	302.5	112	354.6	118	26210	21443		1280		
19XR-A4FA47638GP7	6682	1900	1116	0.167	73.4	374	319.3	89.3	DN450	374.7	81.6	DN450	32472	26795	1321	
19XR-A4FA47648GP7	7034	2000	1186	0.169	78.0	374	336.1	98.6		394.9	89.8		32472	26795	1321	
19XR-A6FB66648GQ7	7385	2100	1200	0.162	79.2	430	352.9	126		413.0	77.1		36283	29292	1650	
19XR-A6GB66648GQ7	7737	2200	1261	0.163	83.0	430	369.7	120		432.7	83.9		36594	29438	1706	
19XR-B6FC65718RU7	8089	2300	1286	0.159	85.2	550	386.5	95.8	DN500	450.7	71.5	DN500	48193	39368	2009	
19XR-B6FC65710RU7	8440	2400	1340	0.159	88.6	550	403.3	104		470.2	77.2		48193	39368	2009	
19XR-B6GC65720RU7	8792	2500	1402	0.159	92.6	550	420.1	93.1		490.3	83.3		48669	39617	2040	
19XR-B6GC66720RU7	9144	2600	1438	0.157	94.9	550	436.9	100		509.1	75.4		49488	40123	2047	
19XR-C6FC66720RU7	9496	2700	1501	0.158	98.9	550	453.7	81.3	DN500	528.5	80.8	DN500	52595	42656	2189	
19XR-C6FC66730RU7	9847	2800	1563	0.159	102.8	550	470.5	87.2		548.8	86.5		52595	42656	2189	
19XR-C6FC67730RU7	10199	2900	1597	0.157	105.0	550	487.3	93.3		567.5	78.7		53451	43179	2197	
19XR-C6FC67730RV7	10551	3000	1666	0.158	109.7	555	504.2	99.6		587.1	83.7		53451	43179	2197	

## Heating application (10kV-3Ph-50Hz)

Model	Chiller				Motor		Evaporator			Condenser			Unit Dimensions			Weight		
	Heating Capacity		Input Power	Full Load Efficiency	RLA	LRYA	Flow Rate	Pressure Drop	Water Connection	Flow Rate	Pressure Drop	Water Connection	Length	Width	Height	Operating	Rigging (w/o Refrigerant)	Refrigerant Charge
	kW	Tons	kW	ikW/kW	A	A	l/s	kPa	mm	l/s	kPa	mm	mm	mm	mm	kg	kg	kg
19XR-7071E35MFD5A	3517	1000	696.1	0.198	45.9	235	134.6	73.6	DN300	170.0	54.4	DN300	5045	2426	2889	19364	16178	1192
19XR-7072E35MFD5A	3869	1100	759.3	0.196	50.2	235	148.4	87.7		187.0	56.6		5045	2426	2889	19625	16369	1192
19XR-7172E37MFD5A	4220	1200	872.3	0.207	57.9	235	159.8	82.8		203.6	66.1		5045	2426	2889	19946	16560	1251
19XR-7274E45MFD5A	4572	1300	889.3	0.195	59.1	235	175.7	86.2		221.0	72.6		5045	2426	2889	20312	16786	1300
19XR-8284E45MHD5A	4924	1400	952.2	0.193	63.2	294	189.5	67.6	DN350	237.5	49.5	DN350	5121	2711	2937	23812	19367	1426

- Note: 1. The above selections are based on entering/leaving chilled water temperature:12/7°C; entering/leaving cooling water temperature:32/37°C. Cooler fouling factor is 0.0176 m<sup>2</sup>C/kW and condenser fouling factor is 0.044 m<sup>2</sup>C/kW.  
 2. The above heating application selections are based on entering/leaving chilled water temperature 10/5°C; entering/leaving cooling water temperature 40/45°C. Cooler fouling factor is 0.0176 m<sup>2</sup>C/kW and condenser fouling factor is 0.044 m<sup>2</sup>C/kW.  
 3. Carrier will select specific models using computer on different requests for tonnage, lift, and efficiency. For details, please contact local agencies.  
 4. Standard water box pressure is 1.0MPa, and can provide 1.6MPa, 2.0MPa as option; For more requirements, please contact local agencies.  
 5. The above selections are made based on the voltage being 10kV. For details or customized selections, please contact local agencies.  
 6. 60Hz selections are also available. Please contact local agencies to get more support.

## 19XR Chiller Dimensions

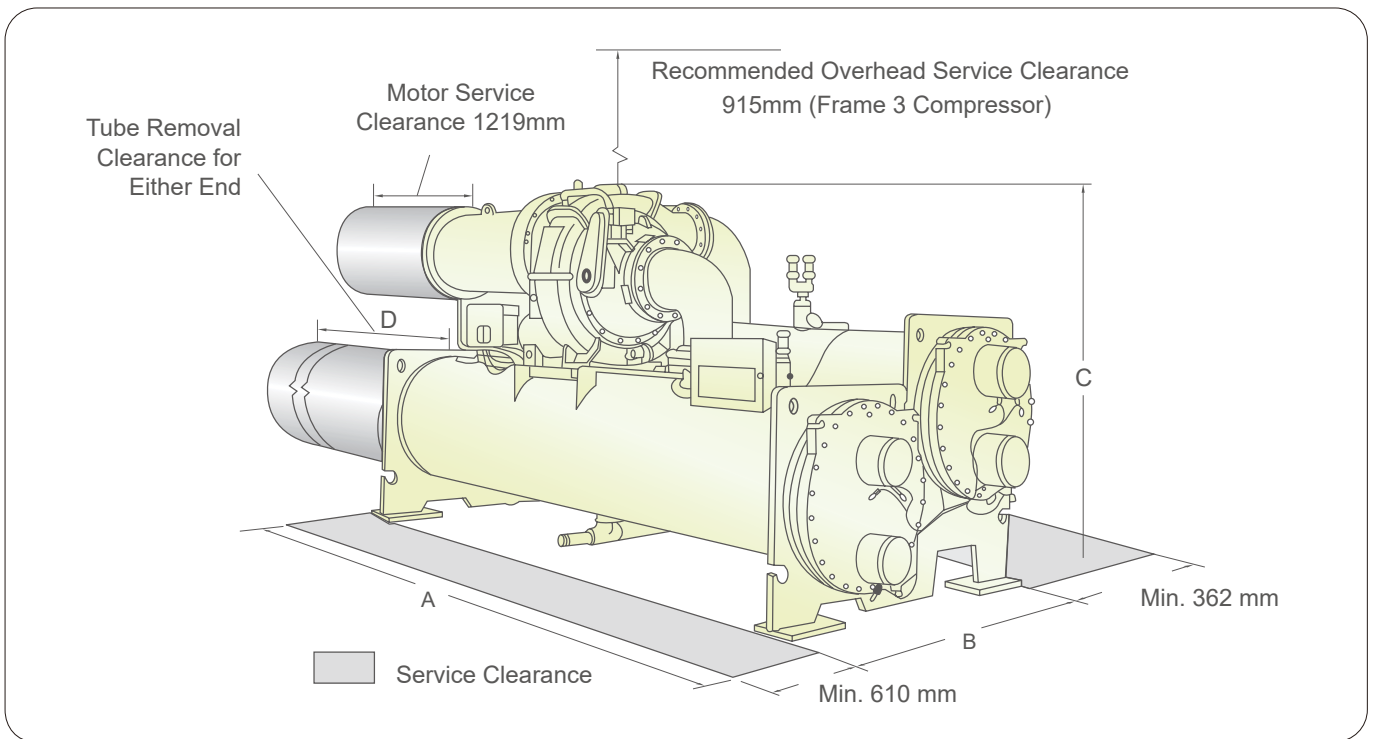

Evaporator Size	Condenser Size	A-Length for NIH Waterbox (2 Passes)	B-Width	C-Height		D-Tube Removal Space for Either End
				without Unit-mounted Starter	with Unit-mounted Y-Δ/Solid State Starter	
				mm	mm	
3P~34	30~34	4181	1670	2051	2051	3848
3X~39	35~39	4702	1670	2051	2051	4369
4P~44	40~44	4359	1880	2130	2403	3848
4X~49	45~49	4880	1880	2130	2403	4369
5P~54	50~54	4394	1994	2137	2829	3848
5X~59	55~59	4915	1994	2137	2829	4369

Notes: 1. A-length includes flanges with both cooler and condenser having two passes and nozzles being at the same end (drive end for standard units)  
 2. The above dimensions are based on the waterside pressure being 1.0Mpa. A-length will vary while the waterside pressure increases.

## 19XR/XR-C/E/F/6/7 Starter Dimensions (Free standing)

Voltage	Starter Type	Frame/Rated Current (A)	Width (mm)	Depth (mm)	Height (mm)
380V	Y-Δ	19XR-3/C≤710A	800	600	2300
		19XR-3/C>710A	1000	600	2300
		19XR-E	1200	800	2200
10kV	Across the Line	19XR-C/E/F/6/7	1000	1650	2400
	Primary Reactor	19XR-C/E/F/6/7	2000	1650	2400
	Auto-transformer	19XR-C/E/F/6/7	2400	1650	2400

Notes: The wiring of 380V starter enters from the top and exits from the bottom.  
 The wiring of 10/11kV starter enters from the top and exits from the top.

## 19XR-C/E/F/6/7 Chiller Dimensions

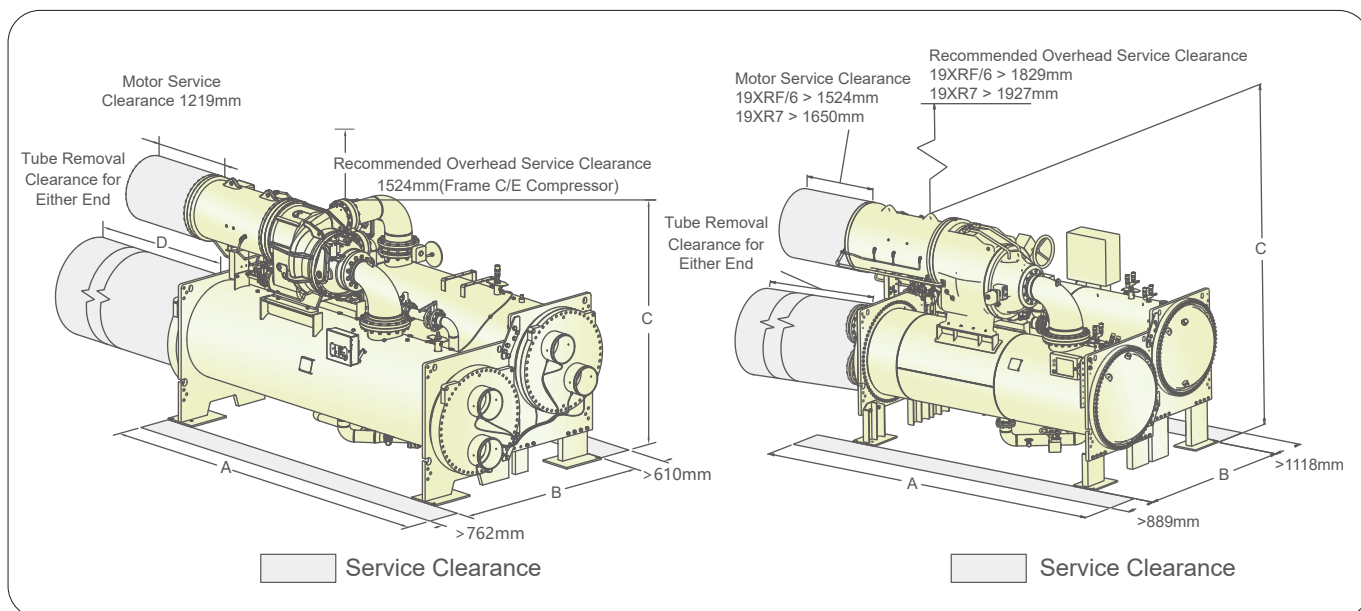

## 19XR-C Unit Dimensions

Evaporator Size	Condenser Size	A-Length for NIH Waterbox (2 Passes)	B-Width	C-Height		D-Tube Removal Space for Either End
				without Unit-mounted Starter	with Unit-mounted Y-Δ/Solid State Starter	
		mm	mm	mm	mm	mm
5P~54	50~54	4393	2098	2421	2850	3747
5X~59	55~59	4921	2078	2421	2850	4343
6P~64	60~64	4419	2163	2637	3071	3747
6X~69	65~69	4940	2148	2637	3071	4343
7P~74	70~74	5051	2472	2743	3155	4267
7X~79	75~79	5660	2472	2743	3155	4877

## 19XR-E/F/6/7 Unit Dimensions

Cooler Size	Condenser Size	A-Length for NIH Waterbox (2 Passes)	B-Width	C-Height		D-Tube Removal Space for Either End
				Without Unit-mounted Starter	With Unit-mounted Y-Δ/Solid State Starter 19XR-E	
		mm	mm	mm	mm	mm
7P~74	70~74	5045	2426	2889	3266	4369
7X~79	75~79	5642	2426	2889	3266	4978
8P~84	80~84	5121	2711	2937	3381	4369
8X~89	85~89	5731	2711	2937	3381	4978
8P~84	V0~V4	5195	2926	3082		4267
8X~89	V5~V9	5805	2926	3082		4877
A4A~A47	A4A~A47	5229	3051	3484		4572
A6A~A67	A6A~A67	5839	3051	3484		5182
A4A~A47	B4A~B47	5229	3186	3484		4572
A6A~A67	B6A~B67	5839	3186	3484		5182
B6A~B67	C6A~C67	5969	3658	3742		5182
C6A~C67	C6A~C67	6019	3798	3813		5182
C6A~C67	D6A~D67	6019	4014	3813		5182
C8A~C87	D8A~D87	6629	4014	3813		5792

Notes: 1. A-length includes flanges with both cooler and condenser having two passes and nozzles being at the same end (drive end for standard units).  
2. The above dimensions are based on the waterside pressure being 1.0Mpa. A-length will vary while the waterside pressure increases.

## Typical Piping and Wiring (with Free-standing Starter)

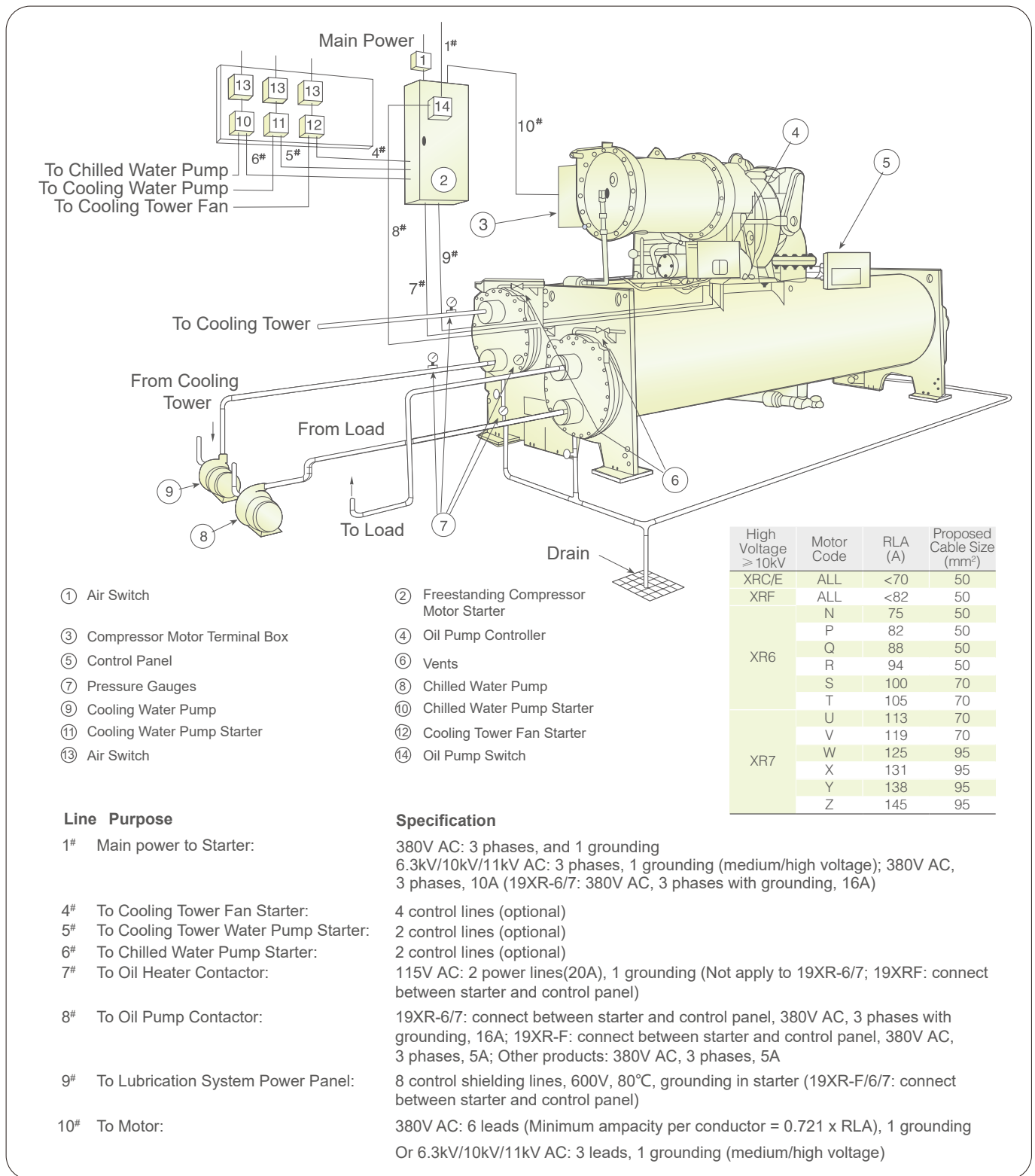

### Piping and Wiring Requirements:

1. The installer must get all pipes and wires in place and mark the ends.
2. Filters must be installed in cooling water and chilled water pipes.
3. Thermometer (0-50°C) and pressure gauge (0~1MPa or 2MPa) must be installed at inlet and outlet of the pipes.
4. The installer must install the relief valve vent to outdoors with a steel pipe(outer diameter 42mm, thickness 4mm).
5. It is suggested that an oxygen content monitor be installed in the machine room for safety, which will give an alarm when the oxygen content is less than 19.5%.
6. Selected cable size range is from 50~120 square millimeter. If the customer select cable size is less than 50 square millimeter or more than 120 square millimeter, please contact YLC factory.
7. Communication cable between starter (ISM module) and control box (IOB module) shall apply Carrier specified one pair and half shielded twisted cable. The cable shall be installed as far away from high voltage cables and other strong jamming equipments as possible and keep the communication cable as shorter as possible to avoid noise. The communication cable must go through a metal conduit independently.

## Typical Piping and Wiring (with VFD)

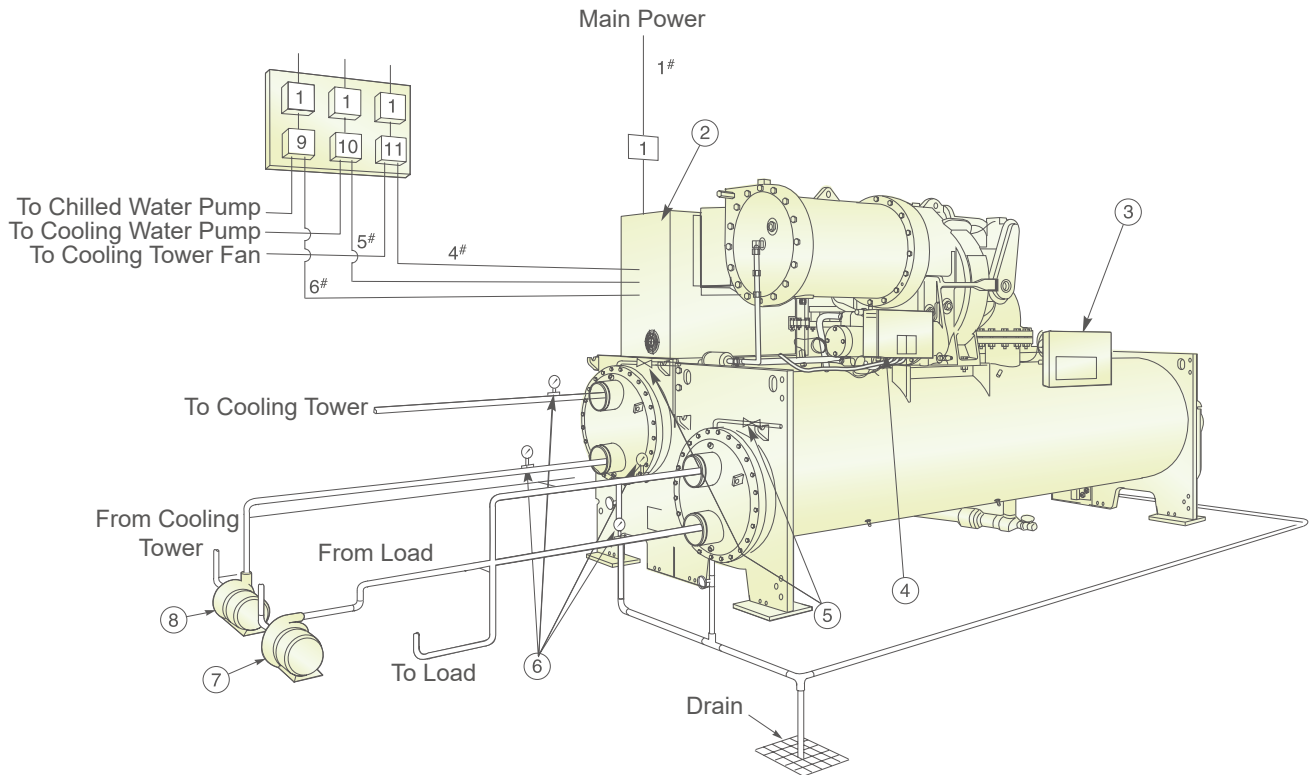

- |                              |                              |                      |                       |
|------------------------------|------------------------------|----------------------|-----------------------|
| ① Air Switch                 | ② Unit-mounted Starter       | ③ Control Panel      | ④ Oil Pump Controller |
| ⑤ Vents                      | ⑥ Pressure Gauges            | ⑦ Chilled Water Pump | ⑧ Cooling Water Pump  |
| ⑨ Chilled Water Pump Starter | ⑩ Cooling Water Pump Starter |                      |                       |

Line	Purpose	Specification
1#	Main power to Starter:	380V AC: 3 phases and 1 grounding
4#	To Cooling Tower Fan Starter:	4 control lines (Please contact local agencies if need this option)
5#	To Cooling Tower Water Pump Starter:	2 control lines (Please contact local agencies if need this option)
6#	To Chilled Water Pump Starter:	2 control lines (Please contact local agencies if need this option)

### Piping and Wiring Requirements:

- The installer must get all pipes and wires in place and mark the ends.
- Filters must be installed in cooling water and chilled water pipes.
- Thermometer (0-50°C) and pressure gauge (0~1MPa or 2MPa) must be installed at inlet and outlet of the pipes.
- The installer must install the relief valve vent to outdoors with a steel pipe(outer diameter 42mm, thickness 4mm).
- It is suggested that an oxygen content monitor be installed in the machine room for safety, which will give an alarm when the oxygen content is less than 19.5%.

# Types of Base Isolation

## Location Of Isolator

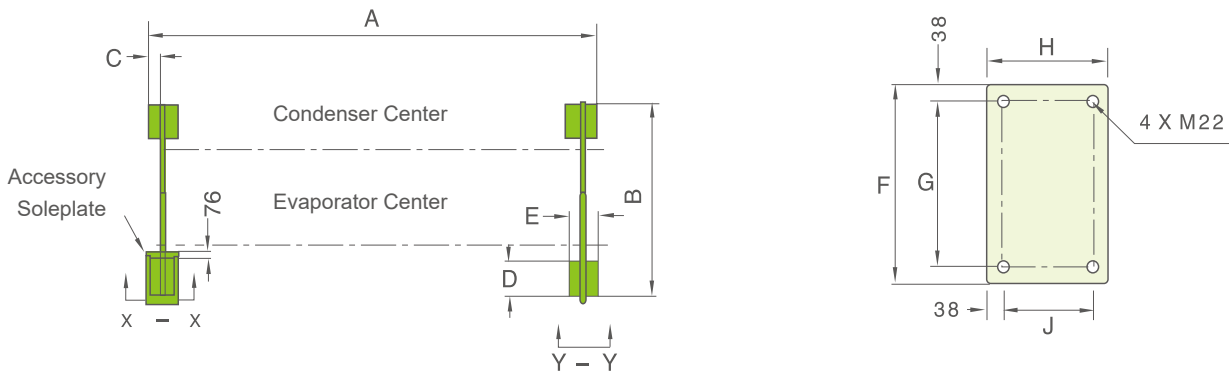

## Standard Isolation

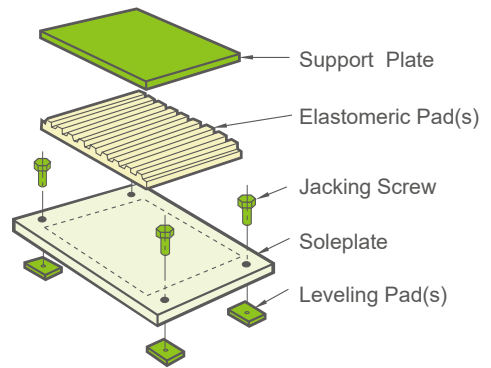
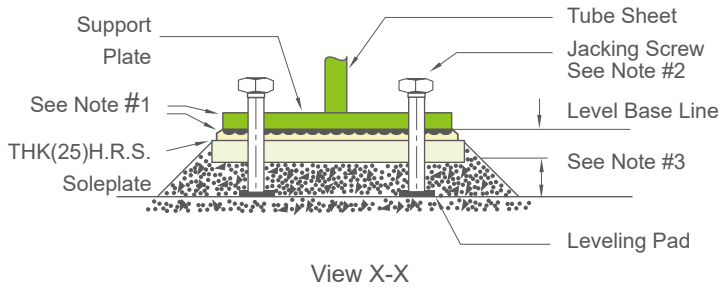

## Simplified Isolation

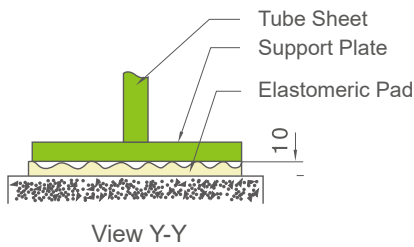

Evaporator/ Condenser model	A	B	C	D	E	F	G	H	J
	mm	mm	mm	mm	mm	mm	mm	mm	mm
3P-34/30-34	3931	1632	92	387	229	540	464	254	178
3X-39/35-39	4451	1632	92	387	229	540	464	254	178
4P-44/40-44	3931	1829	92	387	229	540	464	254	178
4X-49/45-49	4451	1829	92	387	229	540	464	254	178
5P-54/50-54	3931	1969	92	387	229	540	464	254	178
5X-59/55-59	4451	1969	92	387	229	540	464	254	178
6P-64/60-64	3931	2070	92	387	229	540	464	254	178
6X-69/65-69	4451	2070	92	387	229	540	464	254	178
7P-74/70-74	4620	2400	176	559	406	711	635	432	356
7X-79/75-79	5320	2400	176	559	406	711	635	432	356
8P-84/80-84	4620	2686	176	559	406	711	635	432	356
8X-89/85-89	5320	2686	176	559	406	711	635	432	356
8P-84/V0-V4	4620	2686	176	559	406	711	635	432	356
8X-89/V5-V9	5320	2686	176	559	406	711	635	432	356
A4A-A47/A4A-A47	4492	3051	164	559	406	711	635	432	356
A6A-A67/A6A-A67	5102	3051	164	559	406	711	635	432	356
A4A-A47/B4A-B47	4492	3185	164	559	406	711	635	432	356
A6A-A67/B6A-B67	5102	3185	164	559	406	711	635	432	356
B6A-B67/C6A-C67	5082	3632	164	559	406	711	635	432	356
C6A-C67/C6A-C67	5080	3772	164	559	406	711	635	432	356
C6A-C67/D6A-D67	5082	4013	168	559	406	711	635	432	356
C8A-C87/D8A-D87	5691	4013	168	559	406	711	635	432	356

### Notes:

1. Accessory soleplate package includes 4 soleplates, 16 jacking screws, and 16 leveling pads.
2. Jacking Screws should be removed after the grout has set.
3. Thickness of grout varies, depending on the amount necessary to level chiller.



# Field Wiring Specification (with Free-standing Starter)

## I. General

- 1.0 Starters shall be designed and manufactured in accordance with Carrier Engineering Requirement Z-415.
- 1.1 All field-supplied conductors, devices, and the field-installation wiring, termination of conductors and devices, must be in compliance with all applicable codes and job specifications.
- 1.2 The routing of field-installed conduit and conductors and the location of field-installed devices must not interfere with equipment access or the reading, adjusting, or servicing of any component.
- 1.3 Equipment installation and all starting and control devices, must comply with details in equipment submittal drawings and literature.
- 1.4 Contacts and switches are shown in the position they would with the circuit deenergized and the chiller shut down.
- 1.5 **WARNING** - Do not use aluminum conductors.
- 1.6 Installer is responsible for any damage caused by improper wiring between starter and machine.

## II. Power Wiring to Starter

- 2.0 Circuit breaker is to be used to disconnect power to starter.
- 2.1 Lug adapters may be required if installation conditions dictate that conductors be sized beyond the minimum ampacity required.
- 2.2 Compressor motor and controls must be grounded by using equipment grounding lug provided inside starter enclosure.

## III. Control Wiring

- 3.0 Field supplied control conductors should be at least 0.75mm<sup>2</sup> or larger.
- 3.1 Optional ice build start/remote lockout contacts, optional remote start/stop device contacts, optional fire alarm interlock and optional spare safety device contacts, must have 24 VAC rating. MAX current is 60 MA, nominal current is 10 MA. Switches with gold plated bifurcated contacts are recommended. (Not apply to Carrier® SmartVu™ control products. For Carrier® SmartVu™ control products, shall wire from control panel.)
- 3.2 Remove jumper wire between J2-1 and J2-2 before connecting auxiliary safeties between these terminals. (Not apply to Carrier® SmartVu™ control products. For Carrier® SmartVu™ control products, shall wire from control panel.)
- 3.3 Each integrated contact(ISM) output can control loads(VA) for evaporator pump, condenser pump, tower fan low, tow fan high, and alarm annunciator devices rated 5 amps at 115VAC and up to 3 amps at 277VAC. Do not use starter control transformer as the power source for contactor coil loads. ( For Carrier® SmartVu™ control products, these relay outputs can also wire from control panel but rated 1 amp at 24VAC.)
- 3.4 Do not route control wiring carrying 30V or less within a conduit which has wires carrying 50V or higher or along side wires carrying 50V or higher.
- 3.5 Control wiring between free-standing starter and control panel must be separate shielded cables with minimum rating of 600V, 80°C For communication must use shield twist pair wire.
- 3.6 If optional oil pump circuit breaker is not supplied within the starter enclosure as shown, it must be located within sight of the chiller with wiring routed to suit. (Not applicable for 19XR6/7)

## Field Wiring Specification (with Free-standing Starter)

### IV. Power Wiring Between Free-standing Starter and Compressor Motor

- 4.0 Low voltage (600 v or less) compressor motors have (6) 5/8" terminal studs (lead connectors not supplied by Carrier). Either 3 or 6 conductors must be run between compressor motor and starter, depending on the type of motor starter employed. If only 3 leads are utilized, jumper motor terminals as follows : 1 to 6, 2 to 4, and 3 to 5. Center to center distance between terminals is 8mm. Compressor motor starter must have nameplate stamped as to conform with Carrier Engineering Requirement Z-415.
- 4.1 Medium voltage [over 600 volts] compressor motors have (3) terminals. Connections are 9/16-threaded stud. Compressor motor starter must have nameplate stamped as to conform with Carrier Engineering requirement "Z-415."
- 4.2 Power conductor rating must meet minimum unit nameplate voltage and compressor motor RLA. When (3) conductors are used: Minimum ampacity per conductor =  $1.25 \times$  compressor RLA. When (6) conductors are used: Minimum ampacity per conductor =  $0.721 \times$  compressor RLA.
- 4.3 When more than one conduit is used to run conductors from starter to compressor motor terminal box, three leads from each phase (conductor) must be in each conduit to prevent excessive heating (e.g., conductors to motor terminals 1, 2, & 3 in one conduit, and those to 4, 5, & 6 in another).
- 4.4 Compressor motor power conductors may enter terminal box through top, bottom or right side using holes cut by contractor to suit conduit. Flexible conduit should be used for the last few feet to the terminal box for unit vibration isolation.
- 4.5 Compressor motor frame should be grounded in accordance with the National Electrical Code-us (NFPA-70) and applicable codes. Means for grounding compressor motor is a #4 AWG-500 MCM pressure connector, supplied and located in the lower left side corner of the compressor motor terminal box.
- 4.6 Do not allow motor terminals to support weight of wire cables. Use cable supports and strain relieves as required.
- 4.7 Use backup wrench when tightening lead connectors to motor terminal studs.
- 4.8 Motor terminals and wire connectors must be insulated with insulation putties and tapes attached to chillers to prevent moisture condensing and electrical arc.

# Field Wiring Specification (with Unit-mounted VFD)

## I. General

- 1.0 VFD starters shall be designed and manufactured in accordance with Carrier Engineering Requirement Z-420.
- 1.1 All field-supplied conductors, devices, and the field-installation wiring, termination of conductors and devices, must be in compliance with all applicable codes and job specifications.
- 1.2 The routing of field-installed conduit and conductors and the location of field-installed devices must not interfere with equipment access or the reading, adjusting, or servicing of any component.
- 1.3 Equipment installation and all starting and control devices, must comply with details in equipment submittal drawings and literature.
- 1.4 Contacts and switches are shown in the position they would with the circuit deenergized and the chiller shut down.
- 1.5 **WARNING** - Do not use aluminum conductors.

## II. Power Wiring to VFD Starter

- 2.0 Provide a means of disconnecting power to starter. Fused disconnect is required on VFD.
- 2.1 Incoming power wire must be protected with metal jacket.
- 2.2 Line side power conductor rating must meet VFD nameplate voltage and chiller full load amps (minimum circuit ampacity).
- 2.3 Compressor motor and controls must be grounded by using equipment grounding lugs provided inside unit mounted starter enclosure.

## III. Control Wiring

- 3.0 Field supplied control conductors should be at least 0.75 mm<sup>2</sup> or larger.
- 3.1 Optional ice build start/terminate device contacts, optional remote start/stop device contacts and optional spare safety device contacts, must have 24 VAC rating. MAX current is 60 MA, nominal current is 10 MA. Switches with gold plated bifurcated contacts are recommended. (Not apply to Carrier® SmartVu™ control products. For Carrier® SmartVu™ control products, shall wire from control panel.)
- 3.2 Remove jumper wire between TB1-19 and TB1-20 before connecting auxiliary safeties between these terminals. (Not apply to Carrier® SmartVu™ control products. For Carrier® SmartVu™ control products, shall wire from control panel.)
- 3.3 VFD contact outputs can control cooler and condenser pump and tower fan motor contactor coil loads (VA) rated 5 Amps at 115 VAC up to 3 Amps at 250 VAC. Do not use VFD starter control transformer as the power source for contactor coil loads. ( For Carrier® SmartVu™ control products, these relay outputs can also wire from control panel but rated 1 amp at 24VAC.)
- 3.4 Do not route control wiring carrying 30V or less within a conduit which has wires carrying 50V or higher or along side wires carrying 50V or higher.
- 3.5 VFD provide spare output terminal for customer, Input sign must be 4~20mA, not grounded. Input resistance of terminal is soon. (Not apply to Carrier® SmartVu™ control products. For Carrier® SmartVu™ control products, shall wire from control panel.)

19XR/XR-C/E Typical Field Wiring with Free-Standing Starter (Low Voltage)

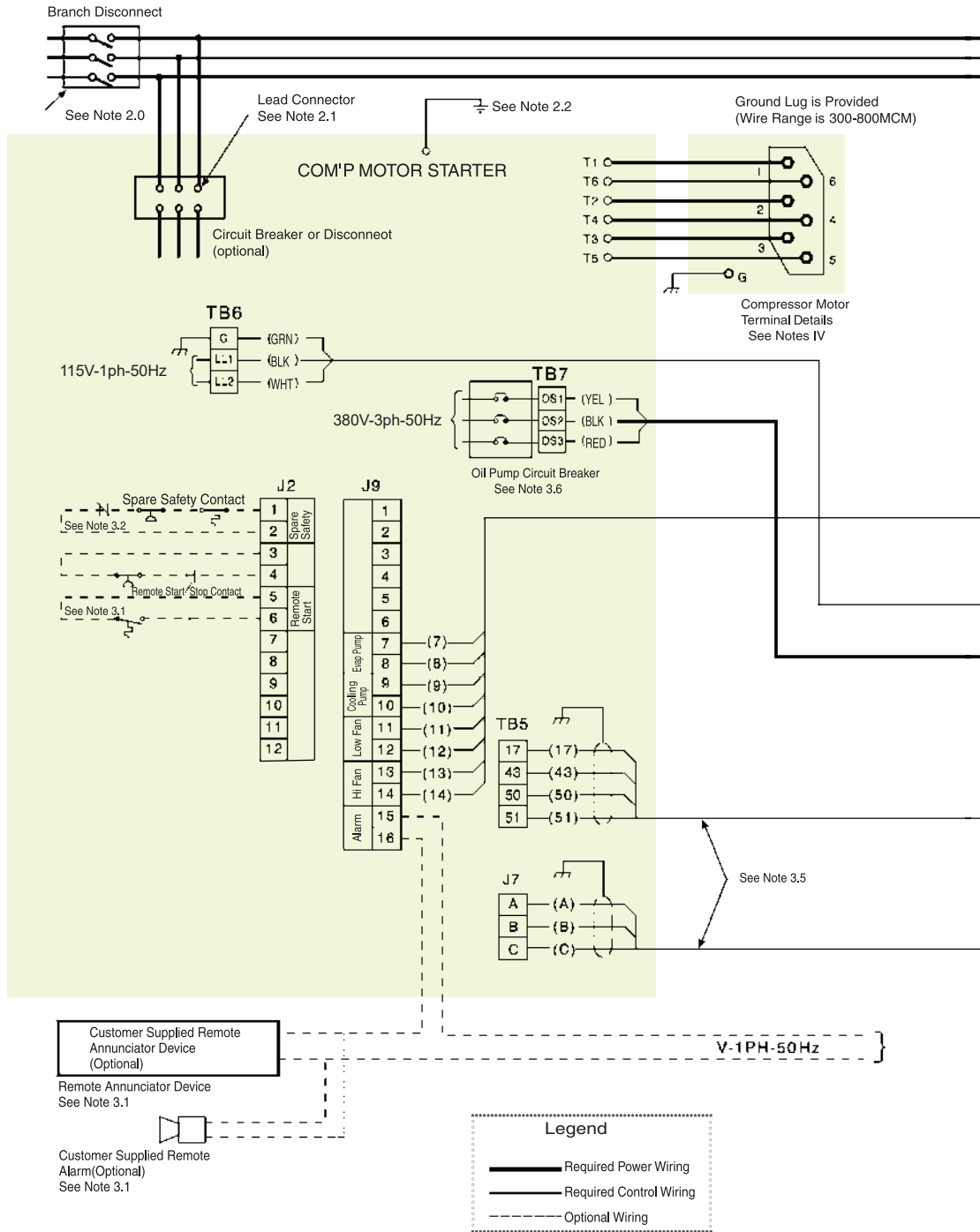

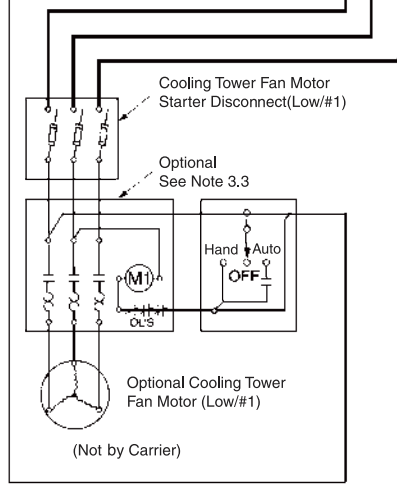
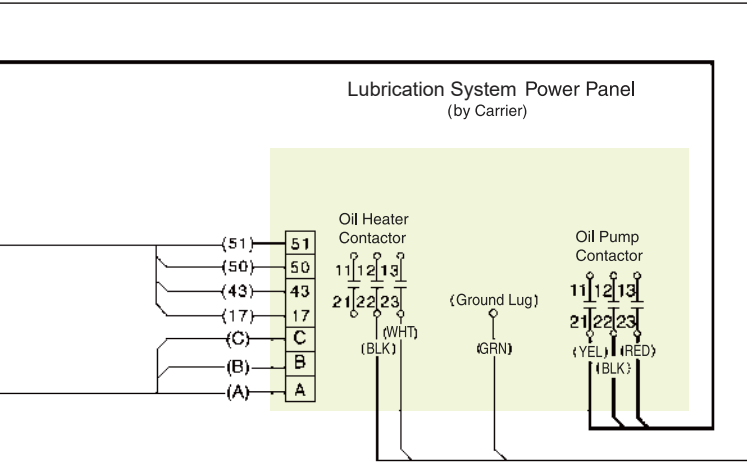
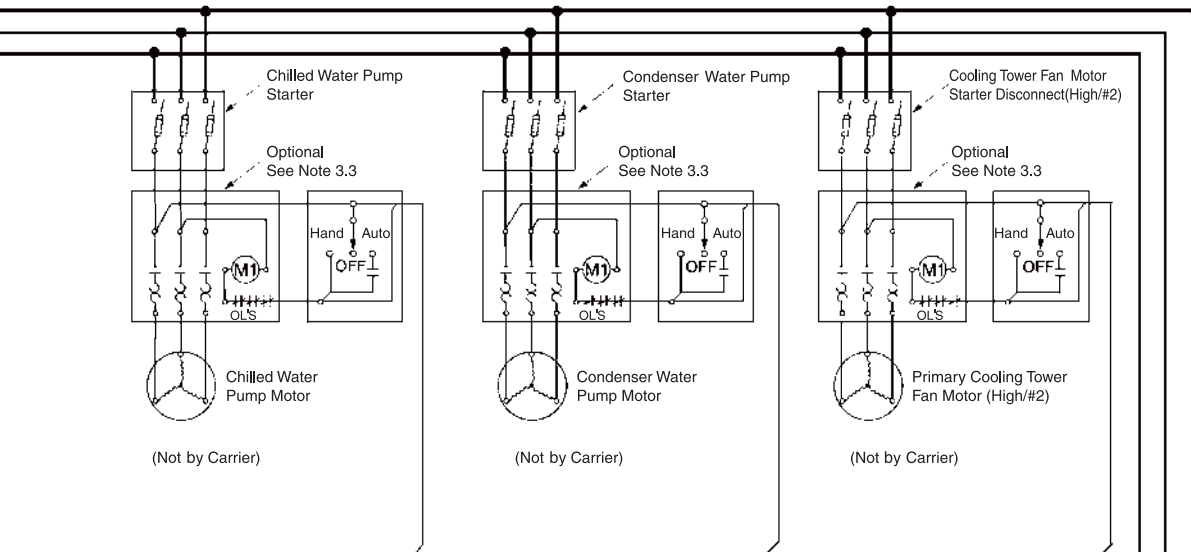

19XR/XR-C/E/F Typical Field Wiring with Free-Standing Starter (Medium/High Voltage)

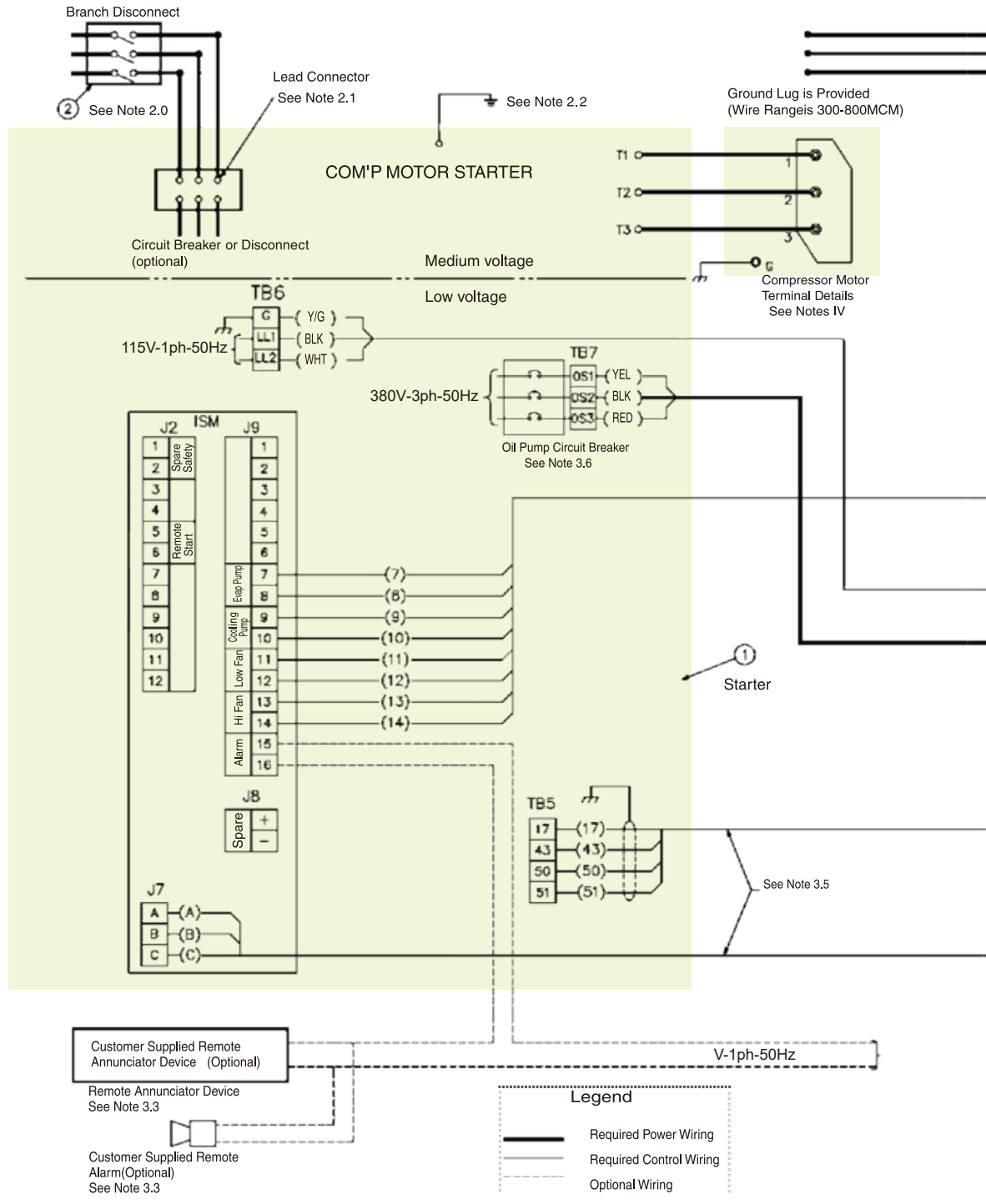

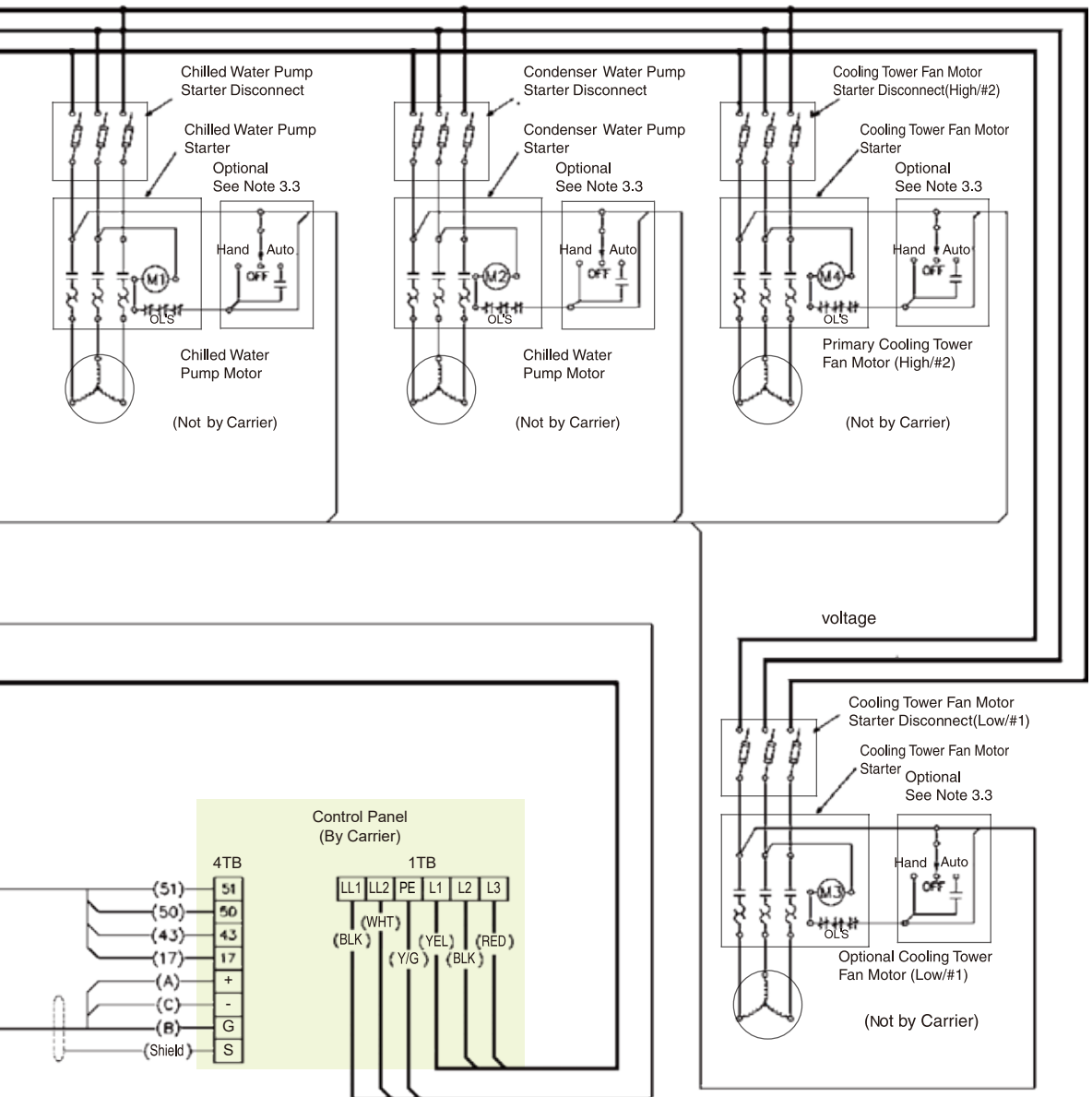

19XRV/XRV-C/E Typical Field Wiring with UM-VFD

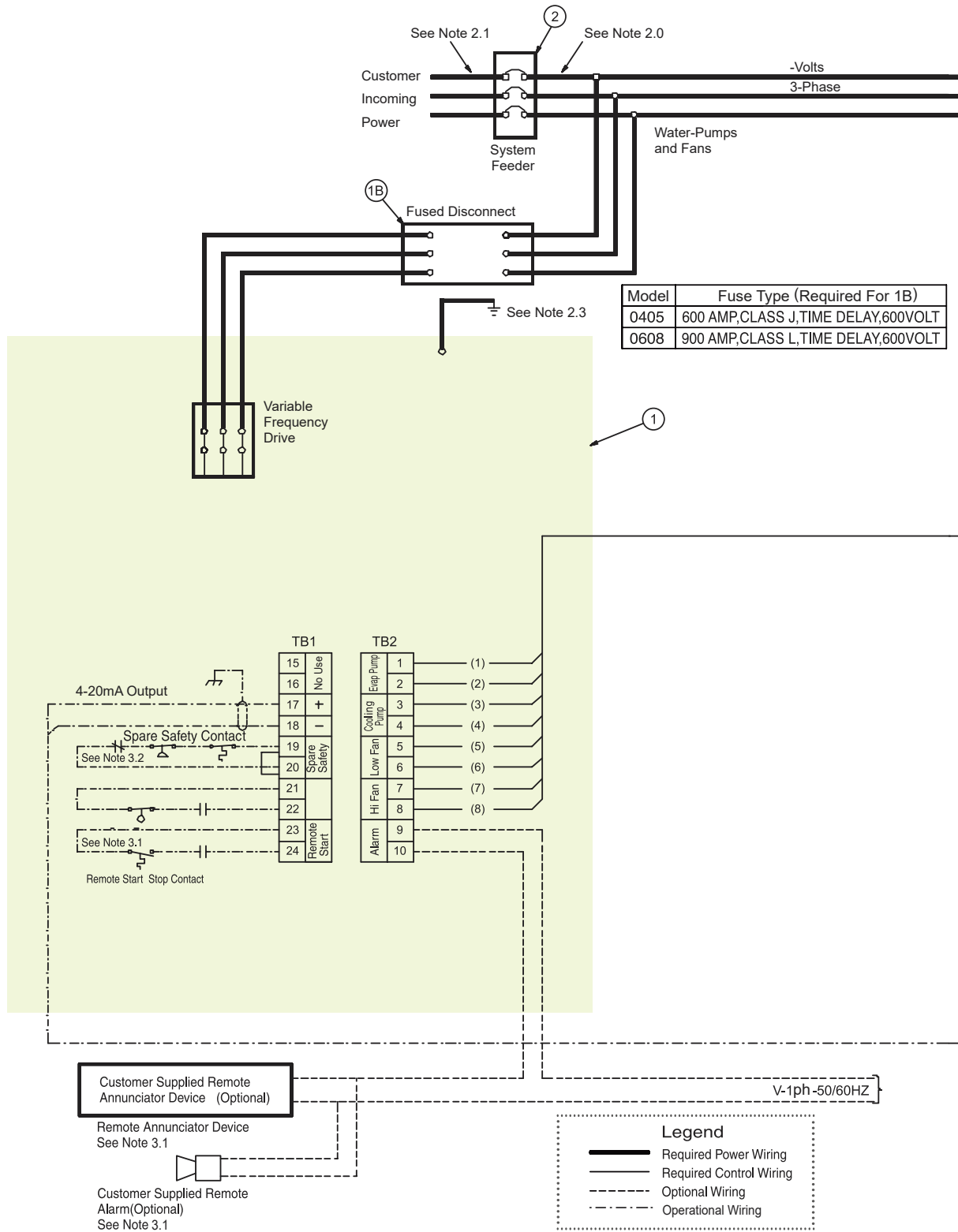



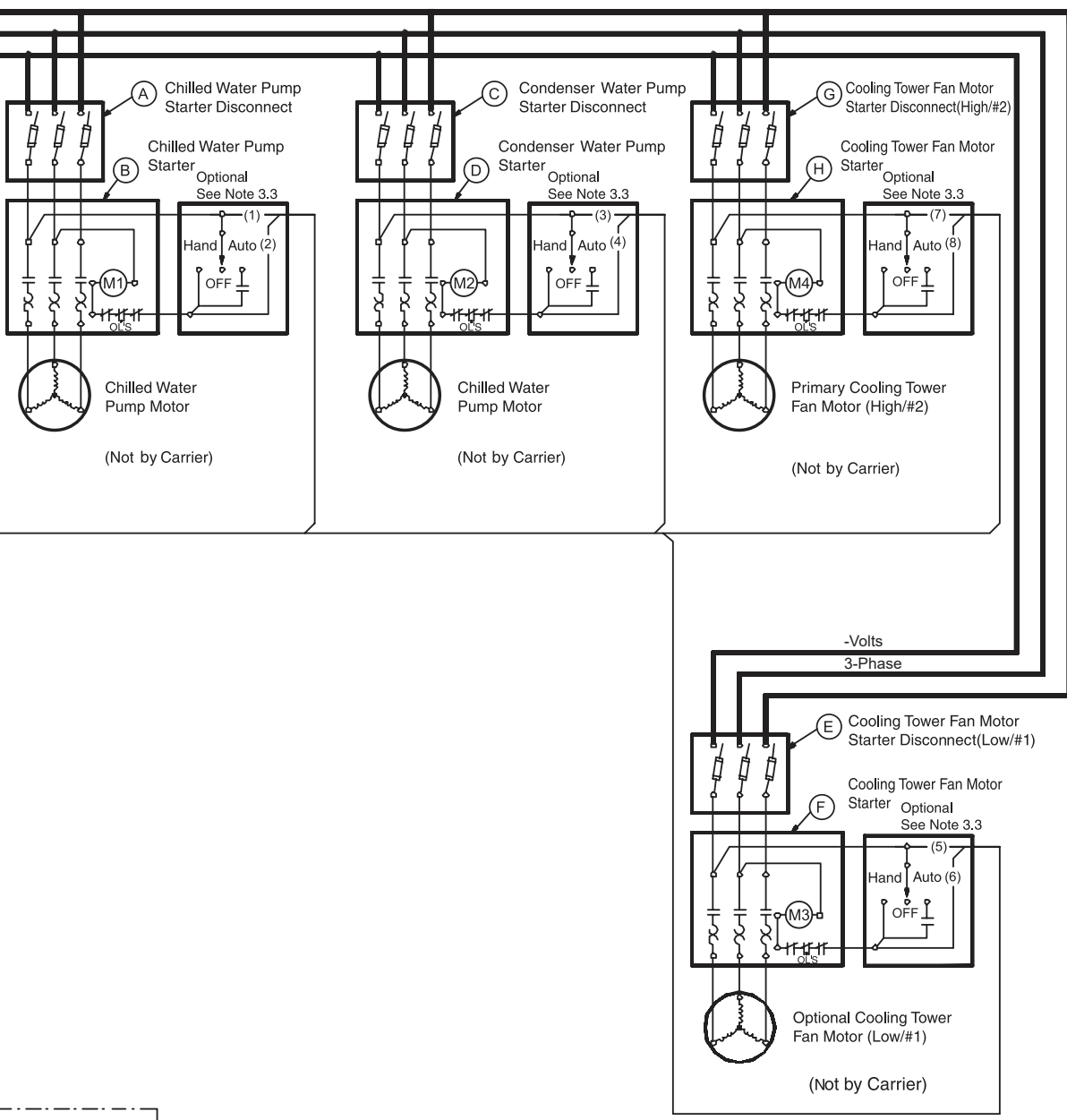

4-20mA Output Reference to Device Choice (Not by Carrier)  
 Examples: Tower Bypass Value  
 Tower Speed Control  
 Condenser Pump Speed Control  
 See Note 3.5

19XR-6/7 Typical Field Wiring with Free-Standing Starter (Medium/High Voltage)

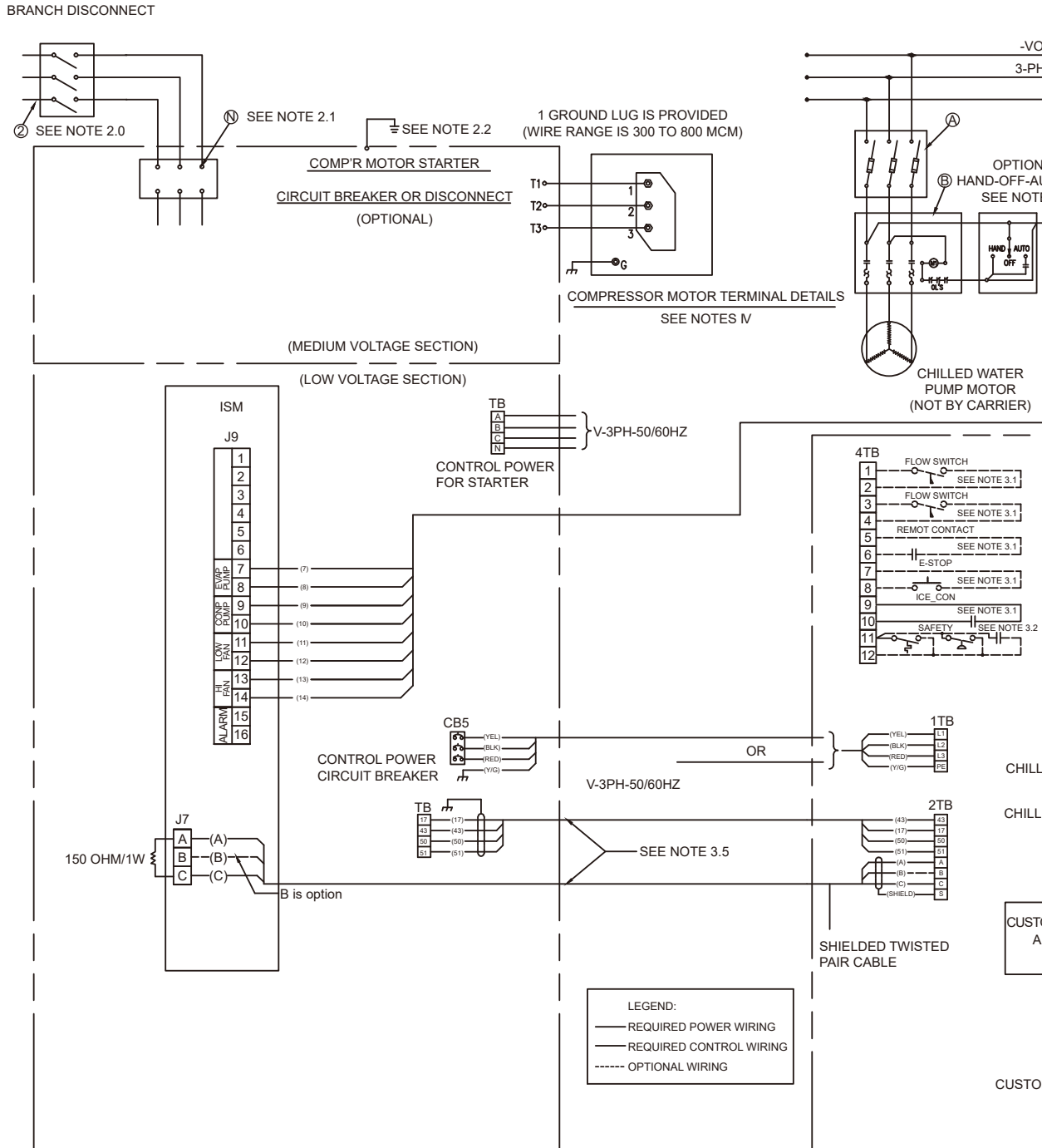

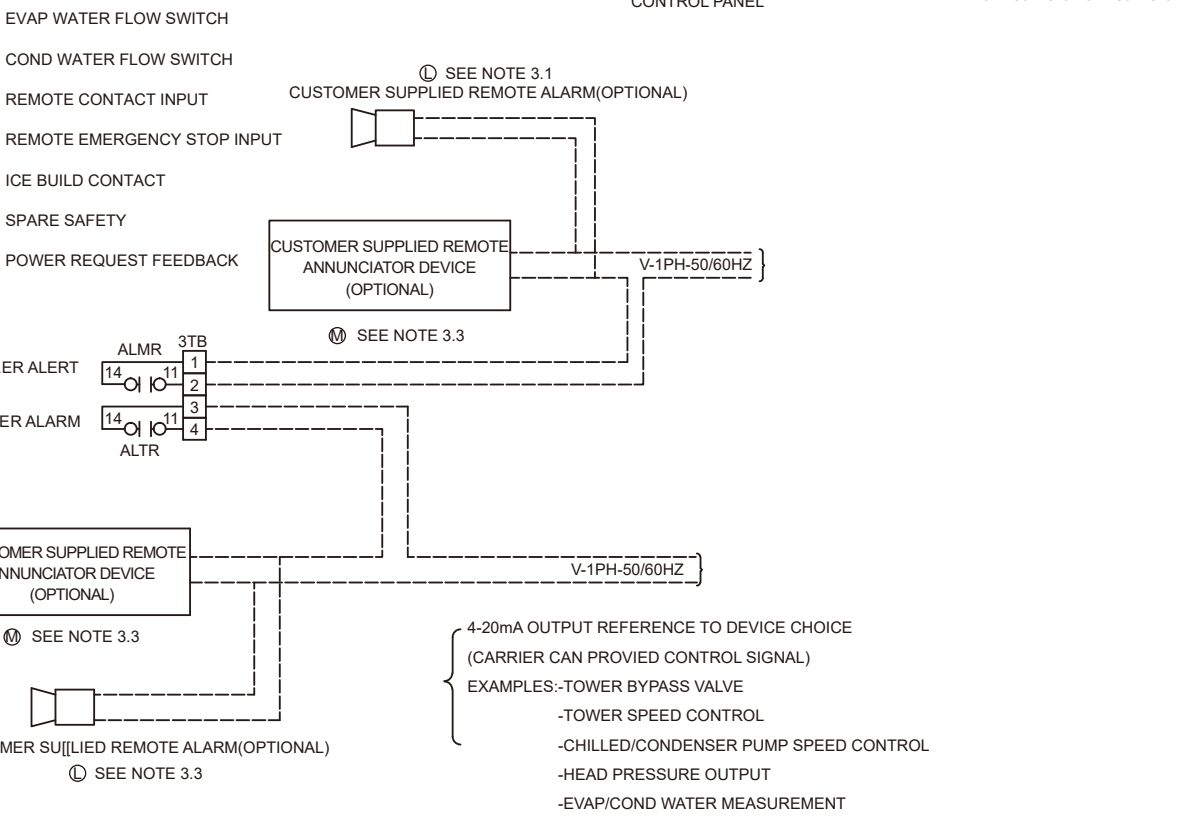
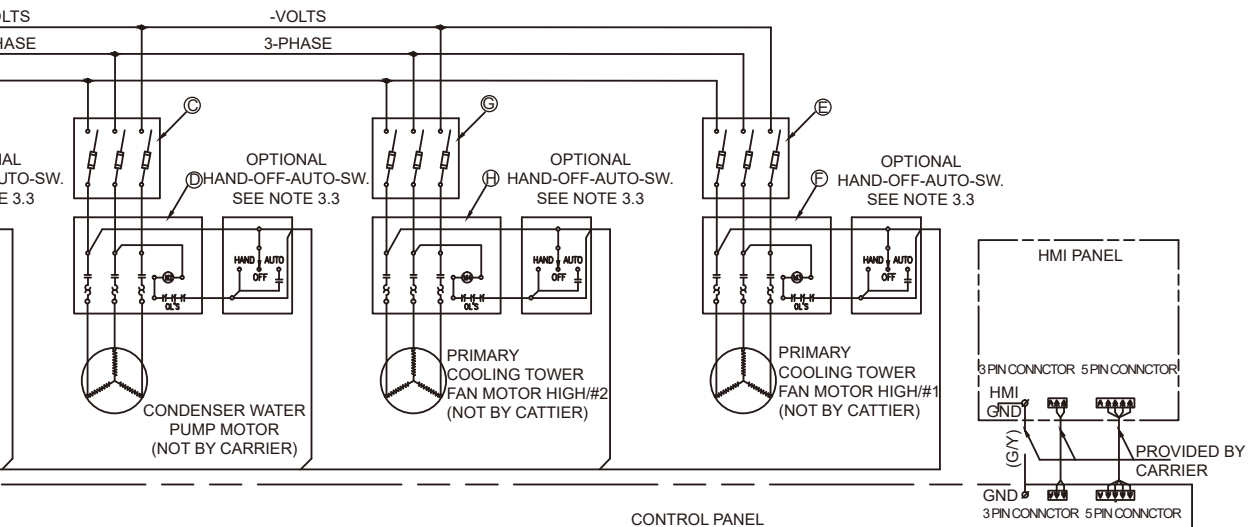



Carrier improves the world around us; Carrier improves people's lives; our products and services improve building performance; our culture of improvement will not allow us to rest when it comes to the environment.



[www.carrier.com](http://www.carrier.com)

The Manufacturer reserves the right to change any product specifications without prior notices  
©ALL Rights Reserved, Carrier® is a registered trademark of Carrier corporation.

Version:	CAT-AQUAEDGE-19XR_E_202407_17
Supersede:	CAT-AQUAEDGE-19XR_E_202310_16
Effective Date:	Jul.2024