



**30KAV
Variable Speed
Air-cooled Screw Chiller**

Nominal cooling capacity: 550~1100kW



Turn To The Experts

Carrier is a leading global provider of innovative HVAC, refrigeration, fire, security and building automation technologies.

Supported by the iconic Carrier name, the company's portfolio includes industry-leading brands such as Carrier, Kidde, Edwards, LenelS2 and Automated Logic.

Carrier's businesses enable modern life, delivering efficiency, safety, security, comfort, productivity and sustainability across a wide range of residential, commercial and industrial applications.



In 1998, Time magazine named Dr. Carrier one of its 20 most influential builders and titans of the 20th century.



Nomenclature

30KAV1100

A

PT002B

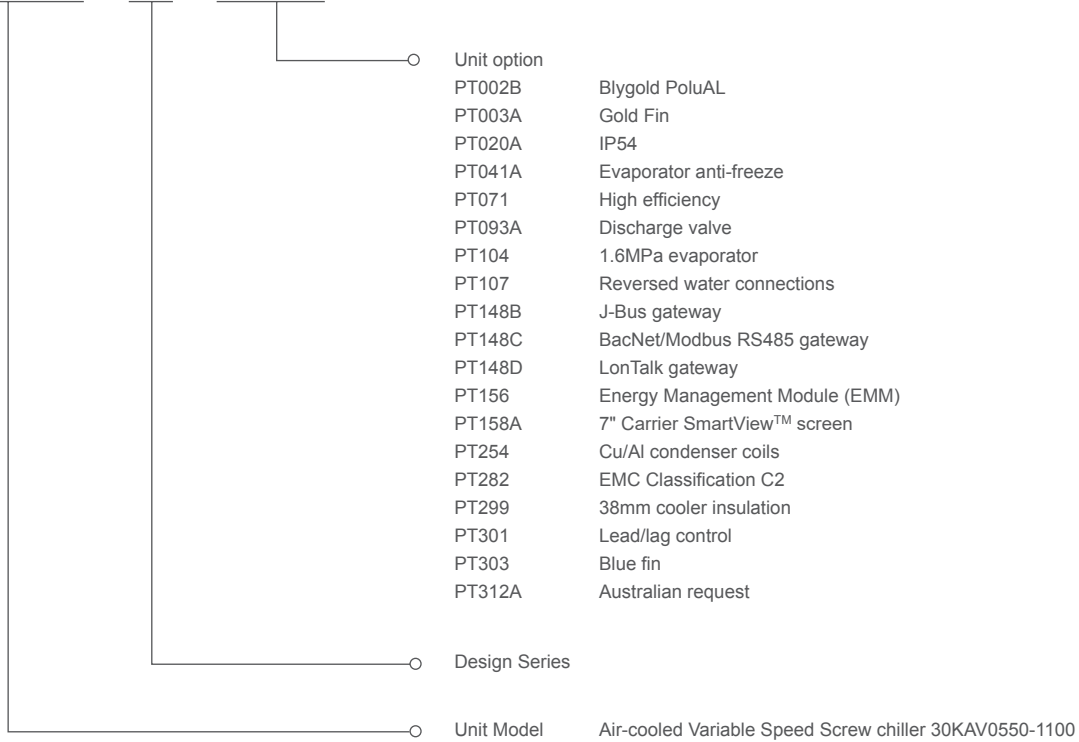

Operating Range

Evaporator		Min. temperature	Max. temperature
Entering water temperature (at start)	°C	-	45
Entering water temperature (operating)	°C	6.8	26
Leaving water temperature (operating)	°C	3.3	20
Condenser		Min. temperature	Max. temperature
Outdoor air temperature	°C	-20	50

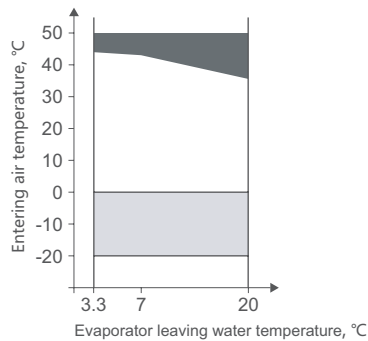

- Below 0°C air temperature the unit must either be equipped with evaporator frost protection option (PT041A), or the water loop must be protected against frost by using a frost protection solution (by the installer).
- Part load average.

Introduction

- ✎ The Aquaforce chillers with Greenspeed® Intelligence are the premium solution for commercial and industrial applications where installers, consultants and building owners require superior reliability and optimal performances, especially at part load.
- ✎ 30KAV are designed to meet current and future requirements in terms of energy efficiency, versatility and operating sound levels. Through the optimised combination of proven best-in-class technologies that include:
 - Exclusive new screw compressors with Greenspeed® Intelligence.
 - The new Touch Pilot control.
 - 6th flying bird Condenser fans with Greenspeed® Intelligence.
- ✎ Furthermore, with 30KAV, Carrier offers its unique expertise and know-how to take care of the machine long after the sale. With the new "CARRIER CONNECT" system in fact, energy and facility managers and end-users in general can rely on the most qualified remote monitoring services.

Low Energy Consumption

- ✎ The air conditioning system could use 30%~40% of annual building energy consumption, 30KAV helps customer involved in green building certification with Greenspeed® inverter-driven technology.
- ✎ With advanced unit mounted inverter-driven technology, the 30KAV is designed for high performance both at full load and at part load. Exceptional efficiency performance at part load which is up to 5.69, customer even can select PT071 (high efficiency) to achieve high performance and energy saving.
- ✎ Cooperating with primary variable flow system, the system efficiency would be further enhanced by synchronized control of chillers and pumps.
- ✎ The high energy efficiency is reached thanks to:
 - Inverter driven twin-rotor screw compressors allowing precise capacity matching of building load and reducing unit power input, especially at part-load.
 - Inverter driven fan motors minimizing power consumption while granting optimum air flow.
 - Electronic expansion device permitting operation at a lower condensing pressure and improved utilization of the evaporator heat exchange surface.
 - Economizer system with electronic expansion device increases cooling capacity by 10% and efficiency by 4%.

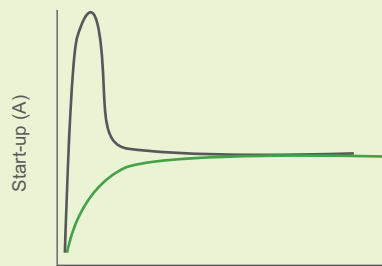
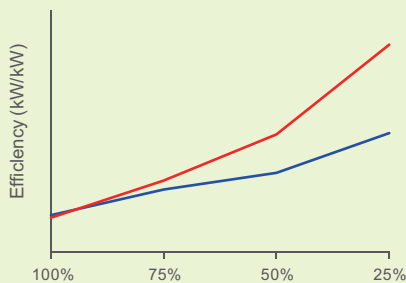
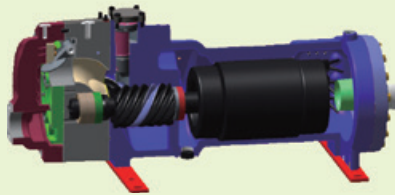

— 30KAV0852 — 30KAV0862A

— Fixed speed — 30KAV

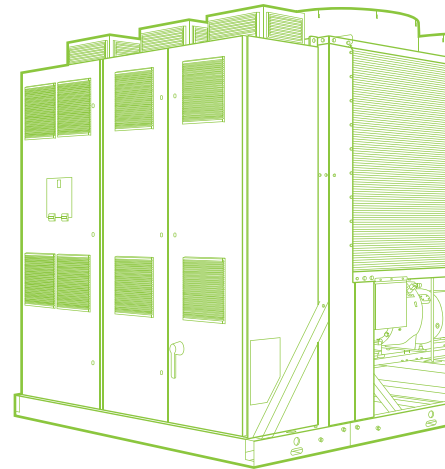

Environmental Friendly

- ✔ HFC-134a refrigerant
Refrigerant of the HFC group with zero ozone depletion potential.
- ✔ Leak-tight refrigerant circuit.
Reduction of leaks as no capillary tubes and flare connections are used.
Verification of pressure transducers and temperature sensors without transferring refrigerant charge.



Absolute reliability

- ✔ Screw compressors with Greenspeed® Intelligence:
 - Industrial-type screw compressors with oversized bearings and motor cooled by suction gas.
 - Specifically sized inverter for each compressor motor ensures reliable operation and easy maintenance.
 - All compressor components assembly are easily accessible on site minimising down-time.
- ✔ Fans with Greenspeed® Intelligence.
 - 6th generation of Flying Bird fans equipped with inverter-driven asynchronous motors.
 - Specifically sized inverter optimize air flow management reducing cost.
 - Easily accessible inverter of fan speed control for easy service.
- ✔ Exceptional endurance tests.
 - Partnerships with specialised laboratories and use of limit simulation tools (finite element calculation) for the design of critical components.
 - Transport simulation test equivalent to 2000 km by truck under harsh conditions.
 - Salt mist corrosion resistance test in the laboratory for increased corrosion resistance.

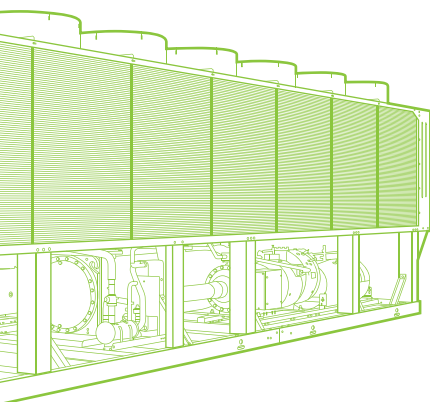

Minimised Operating Sound Levels

- ✔ The inverter technology used for the compressor and fan motors minimises noise levels at part load operation. When the unit is delivering 25% for example, compressors and fans are running at minimum speed which implies lower noise.
- ✔ Standard unit features include:
 - Discharge dampers integrated in the oil separator (Carrier patent).
 - Condenser coils in W-shape with an open angle, allowing quieter air flow across the coil.
 - Low-noise 6th generation Flying Bird fans, made of a composite material (Carrier patent) which do not generate intrusive low frequency noise.



CERTIFIED[®]
www.ahridirectory.org

and 551/591

General Features

🌱 New innovative smart control features:

- An intuitive and user-friendly, 4.3" colored interface (7" as option).
- Screen-shots with concise and clear information in local languages.
- Complete menu, customized for different users (end user, service personnel and Carrier-factory technicians).
- Easy access to the controller box with touch screen mounting to ensure legibility under any lighting conditions.
- Safe operation and unit setting: password protection ensures that unauthorized people cannot modify any advanced parameters.
- Simple and "smart" intelligence uses data collection from the constant monitoring of all machine parameters to optimise unit operation.
- Night-mode: Cooling capacity management for reduced noise level.
- Multiple protocols: BACnet IP & MSTP, Modbus IP & RTU, LON Talk, J-Bus are supported (BACnet IP/Modbus IP as standard).

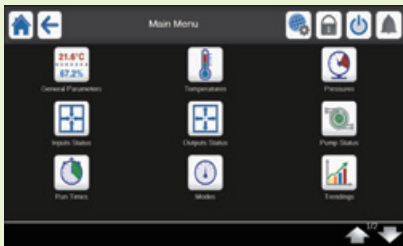

Economical operation

🌱 Energy management:

- Internal time schedule clock controls chiller on/off times and operation at a second set-point.
- The DCT (Data Collection Tool) records the alarms history to simplify and facilitate service operations.

Remote Management (Standard)

- Units with Carrier SmartView™ control can be easily accessed from the internet, using a PC with an Ethernet connection. This makes remote control quick and easy and offers significant advantages for service operations.
- Equipped with an RS485 serial port that offers multiple remote control, monitoring and diagnostic possibilities. When networked with other Carrier equipment through the CCN (Carrier Comfort Network - proprietary protocol), all components form a HVAC system fully-integrated and balanced through one of the Carrier's network system products, like the Chiller System Manager or the Plant System Manager (optional). also communicates with other building management systems via optional communication gateways.

Quiet operation

- ✦ The following commands/visualizations are possible from remote
 - Start/Stop of the machine.
 - Dual set-point management: Through a dedicated contact is possible to activate a second set-point (example: unoccupied mode).
 - Demand limit setting: To limit the maximum chiller capacity to a predefined value.
 - Water pump control: These outputs control the contactors of one/two evaporator water pumps.
 - Operation visualization: Indication if the unit is operating or if it's in stand-by (no cooling load).
 - Alarm visualization.

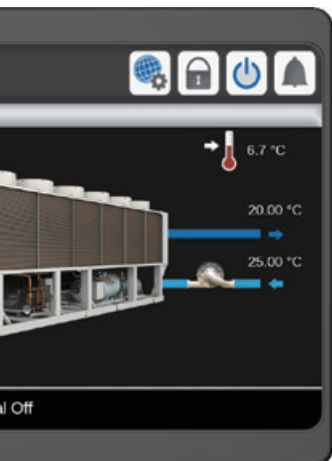

Absolute reliability

- ✦ The Energy Management Module (EMM) offers extended remote control possibilities:
 - Room temperature: Permits set-point reset based on the building indoor air temperature (if Carrier thermostat are installed).
 - Set-point reset: Ensures reset of the cooling set-point based on a 4-20 mA or 0-10 V signal.
 - Demand limit: Permits limitation of the maximum chiller power or current based on 0-10 V signal.
 - Demand limit 1 and 2: Closing of these contacts limits the maximum chiller power or current to two predefined values.
 - User safety: This contact can be used for any customer safety loop; opening the contact generates a specific alarm.
 - Ice storage end: When ice storage has finished, this input permits return to the second set-point (unoccupied mode).
 - Time schedule override: Closing of this contact cancels the time schedule effects.
 - Out of service: This signal indicates that the chiller is completely out of service.
 - Chiller capacity: This analogue output (0-10 V) gives an immediate indication of the chiller capacity.
 - Alert indication: This volt-free contact indicates the necessity to carry out a maintenance operation or the presence of a minor fault.
 - Compressors running status : Set of outputs (as many as the compressors number) indicating which compressors are running.

Performance data

Model	30KAV	0550A	0660A	0700A	0800A	0900A	1000A	1100A	
Nominal cooling capacity*	kW	546.3	664.8	712.9	798.3	887.9	986.2	1068	
Compressor power input	kW	158.1	202.6	211.5	244.0	274.7	298.2	333.4	
Total power input	kW	170.7	215.8	226.1	260.0	292.1	317.0	353.6	
Compressor	VFD Semi-hermetic screw compressor								
CircuitA		1	1	1	1	1	1	1	
CircuitB		1	1	1	1	1	1	1	
Minimum capacity	%	10%	10%	10%	10%	10%	10%	10%	
Refrigerant	R134a								
CircuitA	kg	85	92	92	100	100	125	125	
CircuitB	kg	80	85	90	90	95	95	125	
Control	Carrier SmartView™ system								
Condenser	Cu/Al heat exchanger								
Fans	VI generation FlyingBird axial fan								
Quantity		8	9	10	11	12	13	14	
Total air flow	l/s	40080	45100	50110	55120	60130	65140	70150	
Fan speed	rpm	950							
Evaporator	Flooded multi-pipe								
Water content	l	79	93	93	127	127	146	157	
Nominal water flow	l/s	26.04	31.69	33.98	38.05	42.32	47.01	50.92	
Nominal water pressure drop	kPa	47.2	53.4	46.3	31.1	45.9	46.3	44.4	
Max. water-side pressure (without hydronic module)	kPa	1000							
Water connection	Victaulic								
Nominal Diameter	DN	125	150	150	150	150	200	200	
Electrical data									
Nominal power supply	400V-3Ph-50Hz								
Control power supply	VFD start								
Start-up method	24V via internal transformer								
Fan and control power	kW	12.6	13.2	14.6	16.0	17.4	18.8	20.2	
Nominal unit current draw	Circuit A+B	A	267	339	356	404	452	497	550
Maximum unit current draw	Circuit A+B	A	343	425	450	517	585	610	682
Maximum start-up current	Circuit A+B	A	343	425	450	517	585	610	682
Max operation power	Circuit A+B	kW	221	274	290	333	377	393	439
Unit length	mm	5399	6475	6475	7555	7555	8635	8635	
Unit width	mm	2253							
Unit height	mm	2379							
Shipping weight	kg	5368	5825	5981	6800	7284	7624	7812	
Operating weight (Standard)	kg	5235	5626	5796	6620	7104	7428	7627	

Notes: * Nominal conditions - evaporator entering/leaving water temperature=12/7°C, outdoor air temperature = 35°C Evaporator fouling factor = 0.018m²K/kW

Dimension Drawing

30KAV0550A

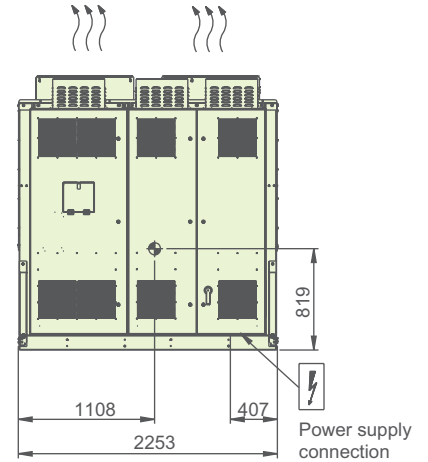
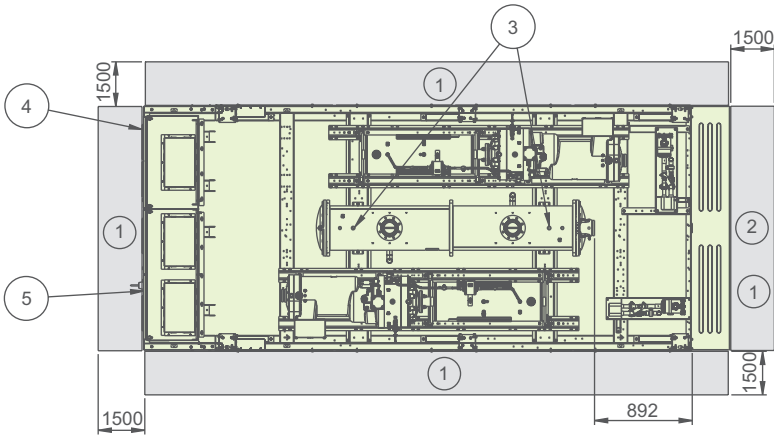
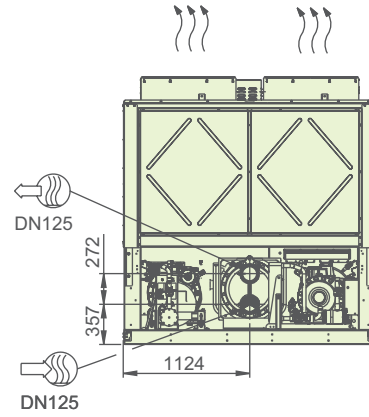
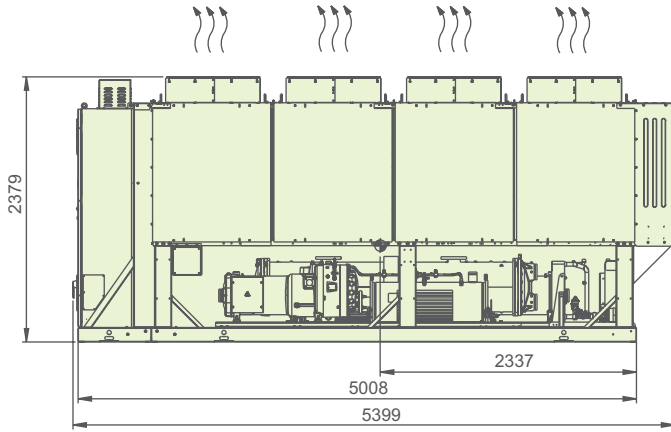

- | | |
|---|-------------------------|
| ① Required clearances for maintenance | Water inlet |
| ② Recommended space for evaporator tube removal | Water outlet |
| ③ Safety valve | Air outlet |
| ④ Fan drive cabinet | Power supply connection |
| ⑤ Comp drive cabinet | Center gravity |

Dimension Drawing

30KAV0660A

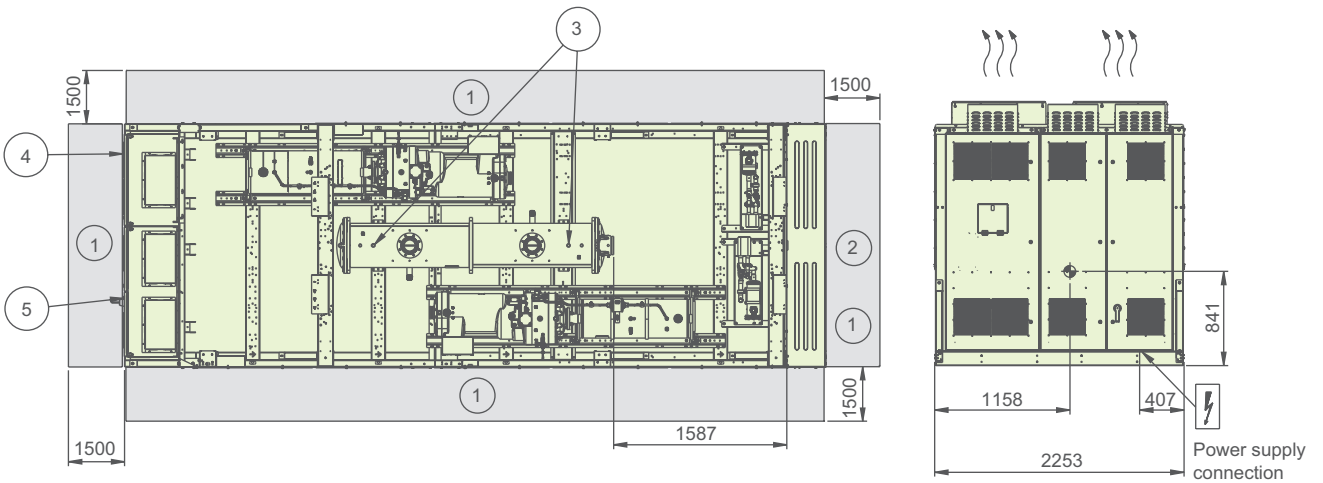
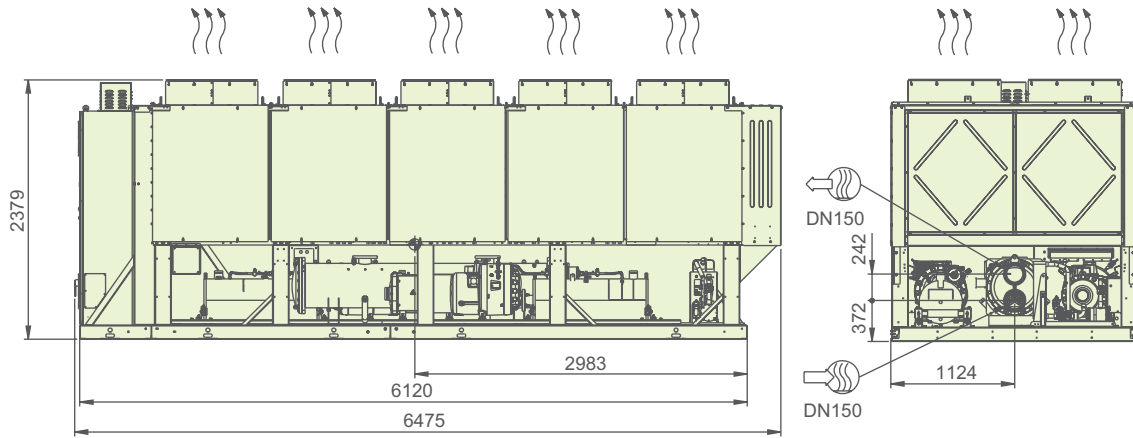

- | | |
|---|-------------------------|
| ① Required clearances for maintenance | Water inlet |
| ② Recommended space for evaporator tube removal | Water outlet |
| ③ Safety valve | Air outlet |
| ④ Fan drive cabinet | Power supply connection |
| ⑤ Comp drive cabinet | Center gravity |

Dimension Drawing

30KAV0700A

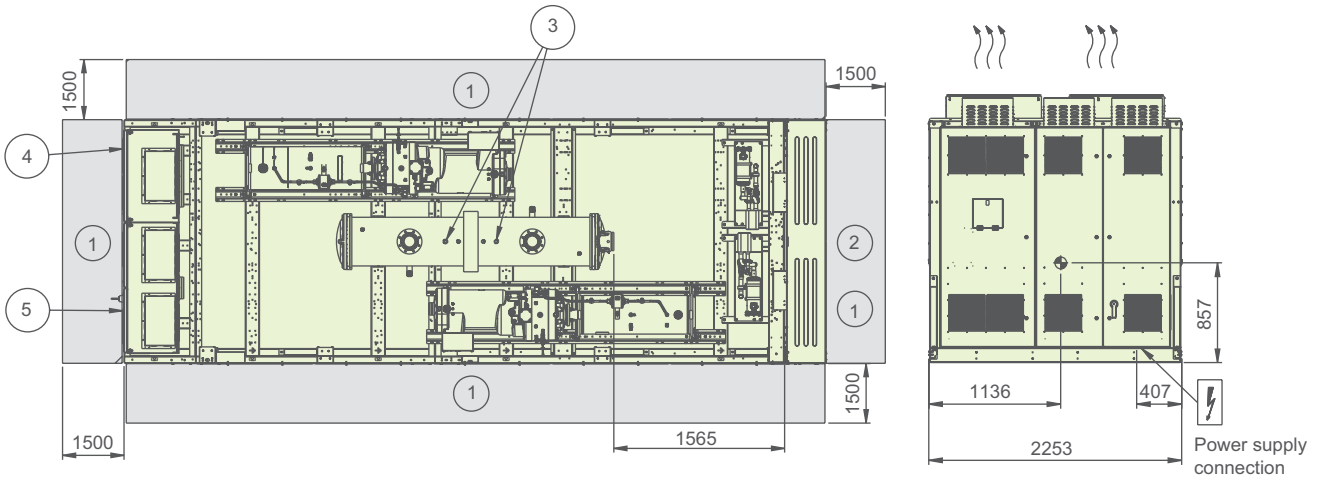
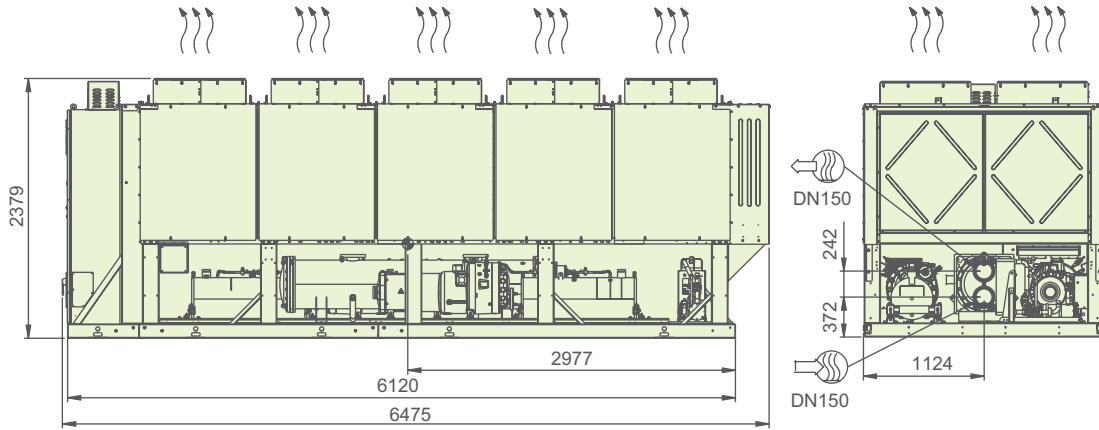

- | | |
|---|-------------------------|
| ① Required clearances for maintenance | Water inlet |
| ② Recommended space for evaporator tube removal | Water outlet |
| ③ Safety valve | Air outlet |
| ④ Fan drive cabinet | Power supply connection |
| ⑤ Comp drive cabinet | Center gravity |

Dimension Drawing

30KAV0800A

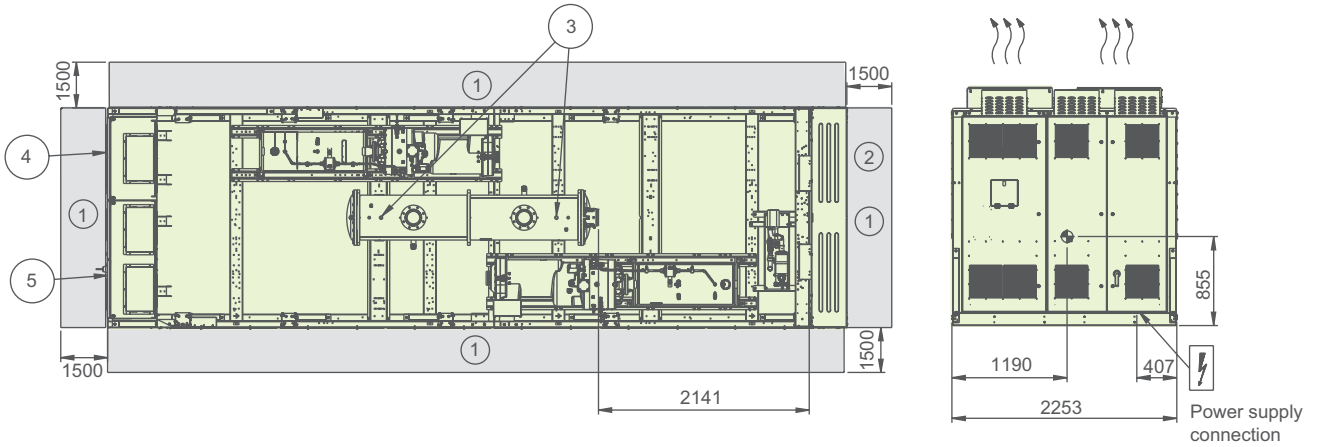
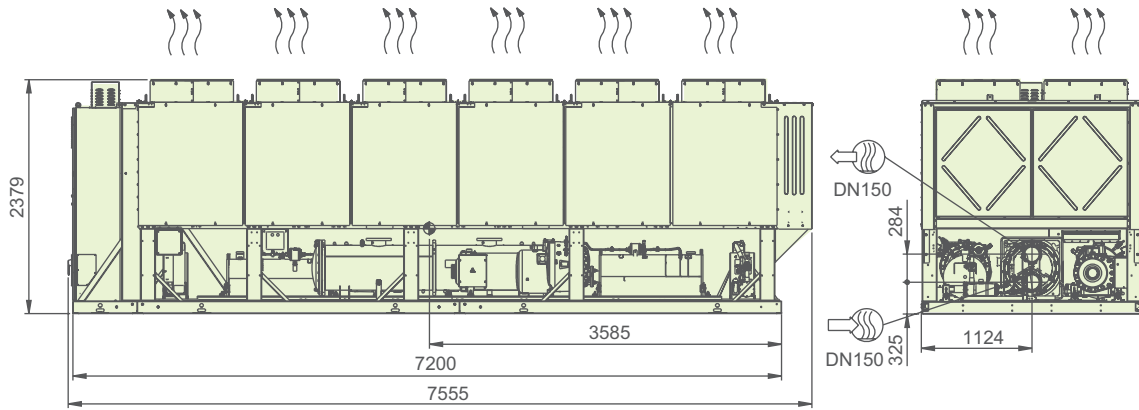

- | | |
|---|-------------------------|
| ① Required clearances for maintenance | Water inlet |
| ② Recommended space for evaporator tube removal | Water outlet |
| ③ Safety valve | Air outlet |
| ④ Fan drive cabinet | Power supply connection |
| ⑤ Comp drive cabinet | Center gravity |

Dimension Drawing

30KAV0900A

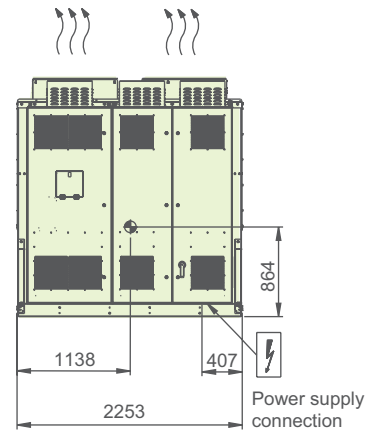
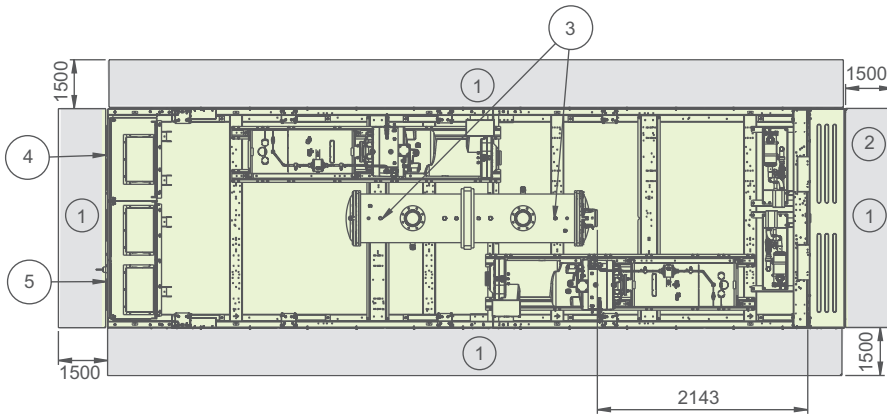
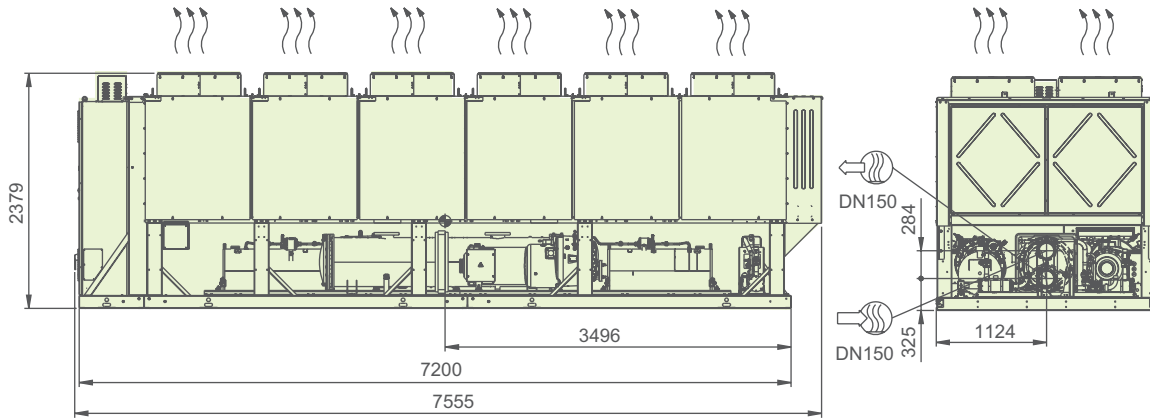

- | | |
|---|-------------------------|
| ① Required clearances for maintenance | Water inlet |
| ② Recommended space for evaporator tube removal | Water outlet |
| ③ Safety valve | Air outlet |
| ④ Fan drive cabinet | Power supply connection |
| ⑤ Comp drive cabinet | Center gravity |

Dimension Drawing

30KAV1000A

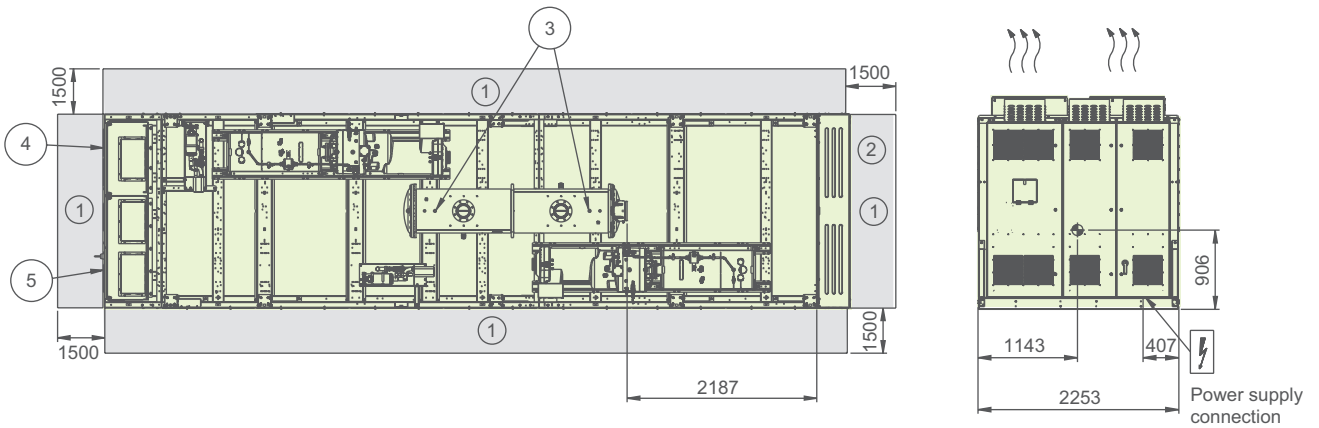
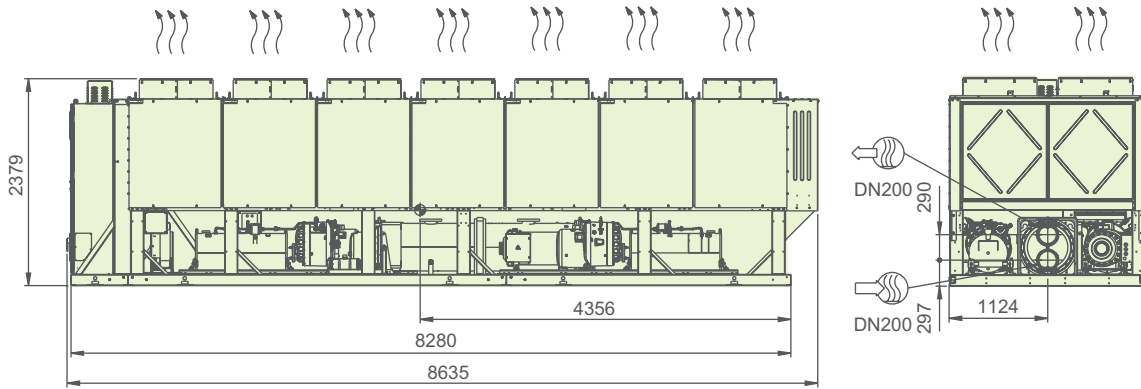

- | | |
|---|-------------------------|
| ① Required clearances for maintenance | Water inlet |
| ② Recommended space for evaporator tube removal | Water outlet |
| ③ Safety valve | Air outlet |
| ④ Fan drive cabinet | Power supply connection |
| ⑤ Comp drive cabinet | Center gravity |

Dimension Drawing

30KAV1100A

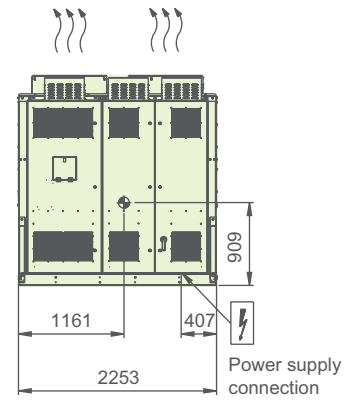
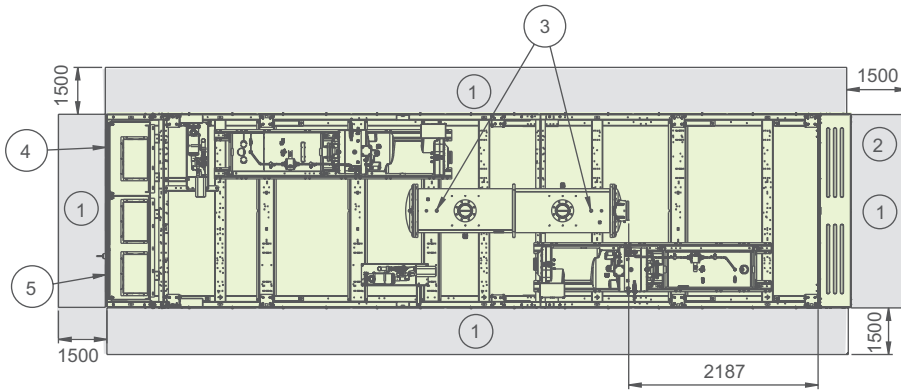
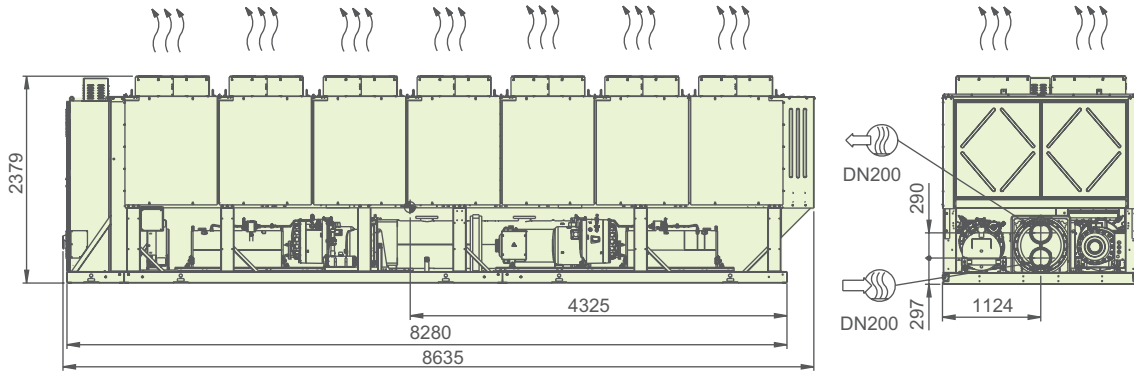

- | | |
|---|-------------------------|
| ① Required clearances for maintenance | Water inlet |
| ② Recommended space for evaporator tube removal | Water outlet |
| ③ Safety valve | Air outlet |
| ④ Fan drive cabinet | Power supply connection |
| ⑤ Comp drive cabinet | Center gravity |



Carrier improves the world around us; Carrier improves people's lives; our products and services improve building performance; our culture of improvement will not allow us to rest when it comes to the environment.



www.carrier.com

The Manufacturer reserves the right to change any product specifications without prior notices
© All Rights Reserved Carrier

Version:	CAT_30KA_E-1911-06
Supersede:	CAT_30KAV_E-1905-05
Effective date:	Nov, 2019