



40LM Chilled Water Fan Coil Unit

A Benchmark in Versatile Cooling Performance



Carrier International Sdn Bhd

Carrier International Sdn Bhd is our state-of-the-art manufacturing facility where we employ the latest technologies and expertise to bring you truly comprehensive HVAC solutions. Spread across oceans, CISB serves customers in over 20 countries in the Middle East and Asia Pacific.

With decades of carefully honed insights, we are honored to have won the trust of our valued stakeholders world-over. This includes industry-accredited institutions who have awarded us multiple accolades which we always work to uphold.



 Selangor, Malaysia



Operations
1962–present



Regional
Multi-purpose Training Hub
and Experience Centre

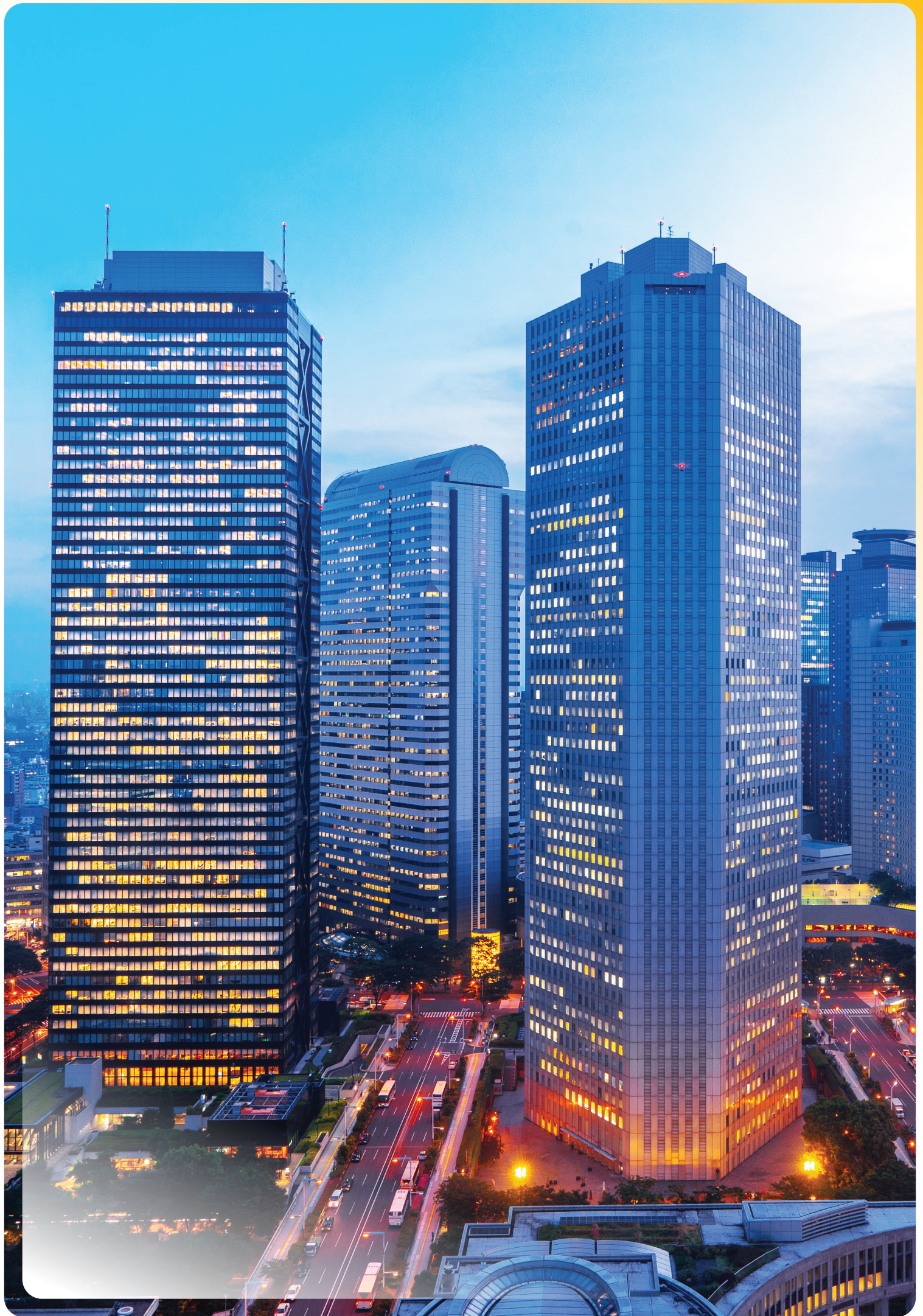

40LM Fan Coil Unit

Features and Specifications

40LM Fan Coil Unit Series is equipped with innovative technologies and a versatile design to meet the needs of diverse applications such as residential spaces, hotels, offices, hospitals, schools and multiroom buildings.



The system is a chilled water furred-in model with Plenum Fan Coil units.

The low-silhouette construction of the unit makes it an ideal choice across various building types.



Offered with an insulated & painted condensate drain pan and a factory-fitted frame complete with filter media.

Equipped with a 3-speed direct drive motor as a standard.



Equipped with up to 4 cooling coils to provide maximum cooling capacity and efficiency.

A standard copper tube aluminum fin (Cu/Al) evaporator coil is included for maximum heat transfer performance.



Energy-efficient performance is ensured with Carrier Lanced Sine Wave Fin pattern.





Technical Specifications

GENERAL									
Type		Chilled Water Fan Coil Unit							
Model	40LM-	040	050	060	070	100	120	150	200
Nominal Capacity	kW	8.8	11.7	14.8	19.1	27.0	29.8	43.7	62.2
	Btu/hr	30,139	39,866	50,652	65,218	92,268	1,01,745	1,49,379	2,06,278
Air Quantity (Range)	l/s	699	643	795	907	1,321	1,420	2,148	2,926
Power Supply	V / Ph / Hz	230 / 1 / 50							
Fan									
Type		Centrifugal Forward-Curved Blades							
Drive		Direct Drive							
Quantity	Pcs	2						3	
Motor									
Type		Permanent Split Capacitor, 3 Speeds							
Quantity	Pcs	1						2	
Power Output	W	300	300	450	450	750	800	800 / 462	960 / 640
Full Load Amp	A	2.50	2.50	3.00	3.00	6.07	7.84	11.59	12.93
Coil									
Type		Copper Tube, Aluminium Plate Fins							
Row - Fins/in		3 - 18	4 - 15	4 - 18	4 - 18	4 - 15	4 - 15	4 - 15	4 - 18
Face Area	m ²	0.33	0.33	0.33	0.40	0.60	0.60	0.81	1.08
Filter									
Type		Washable							
Quantity	Pcs	1						2	1
Connections									
Supply	Inch	1" BSPT MPT							
Return	Inch	1" BSPT MPT							
Drain Pipe	Inch	3/4" NPT MPT							
Dimensions									
Height	mm	347				458		469	680
Width	mm	749				675		963	965
Length	mm	1,067			1,218	1,627		1,990	1,946
Weight									
Net Weight	kg	40.0	42.5	42.5	47.5	78.0	78.0	111.0	160.0
Gross Weight	kg	44.0	46.5	46.5	51.5	90.0	90.0	123.0	172.0

Physical Dimensions

40LM040 / 050 / 060

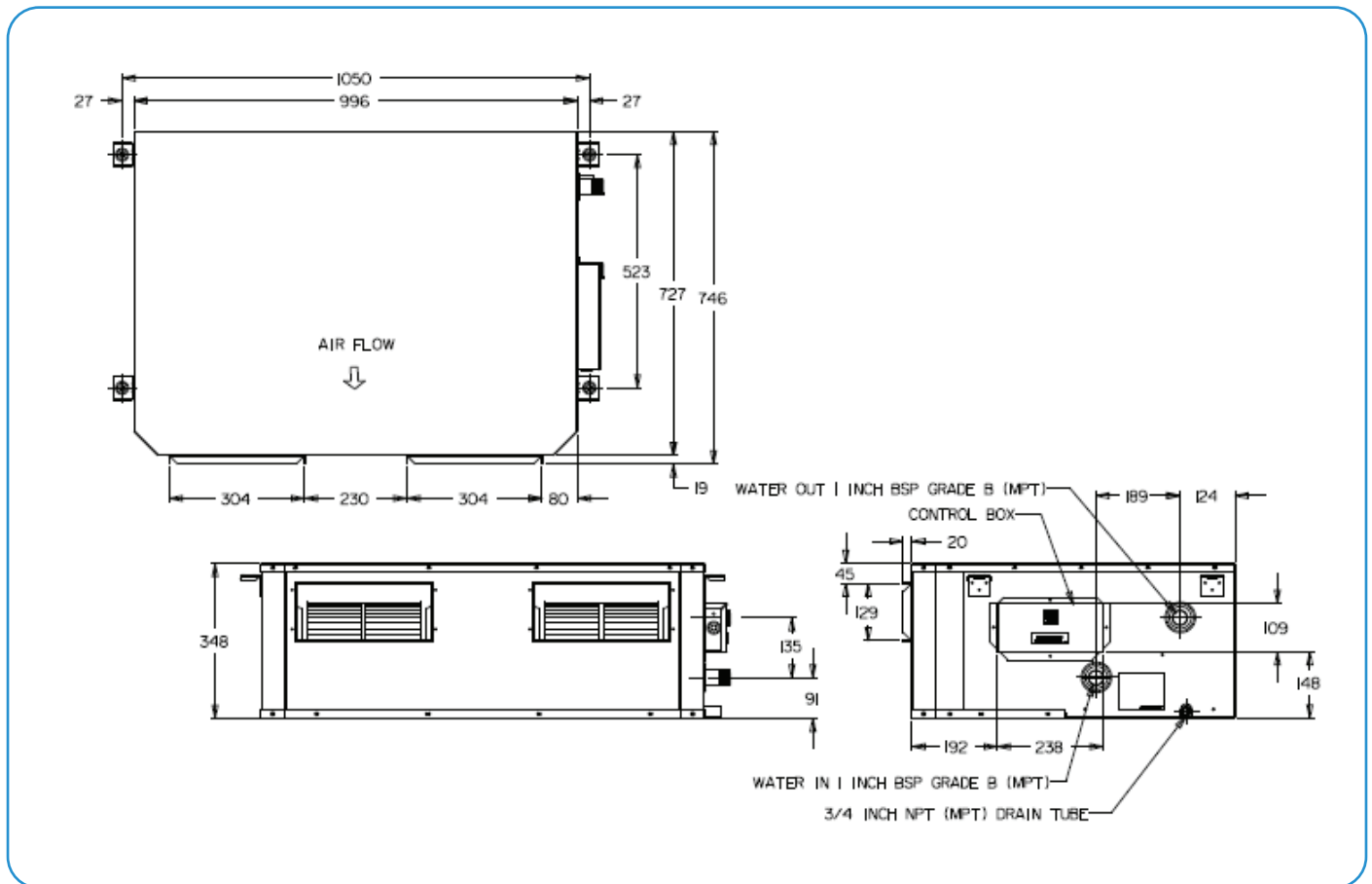

40LM070

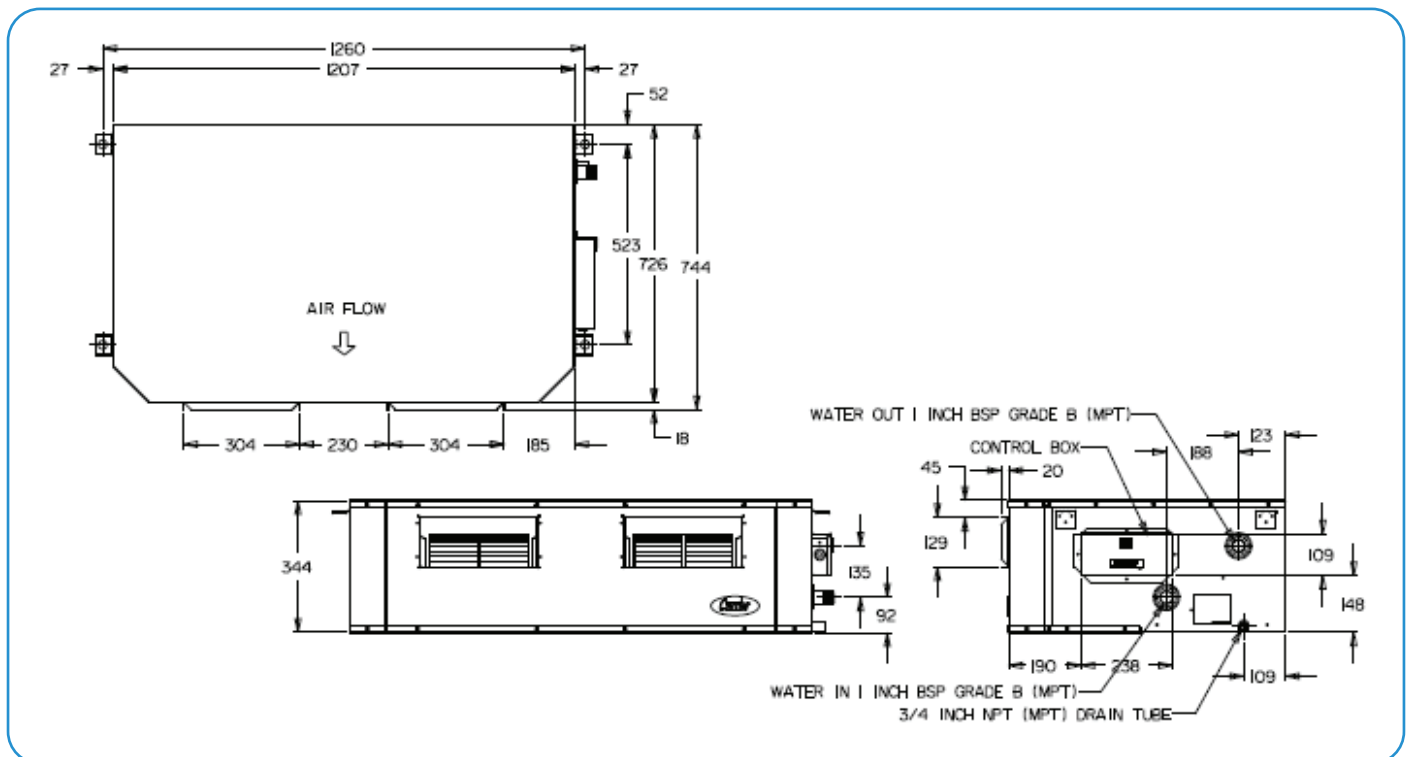

Physical Dimensions

40LM100 / 120

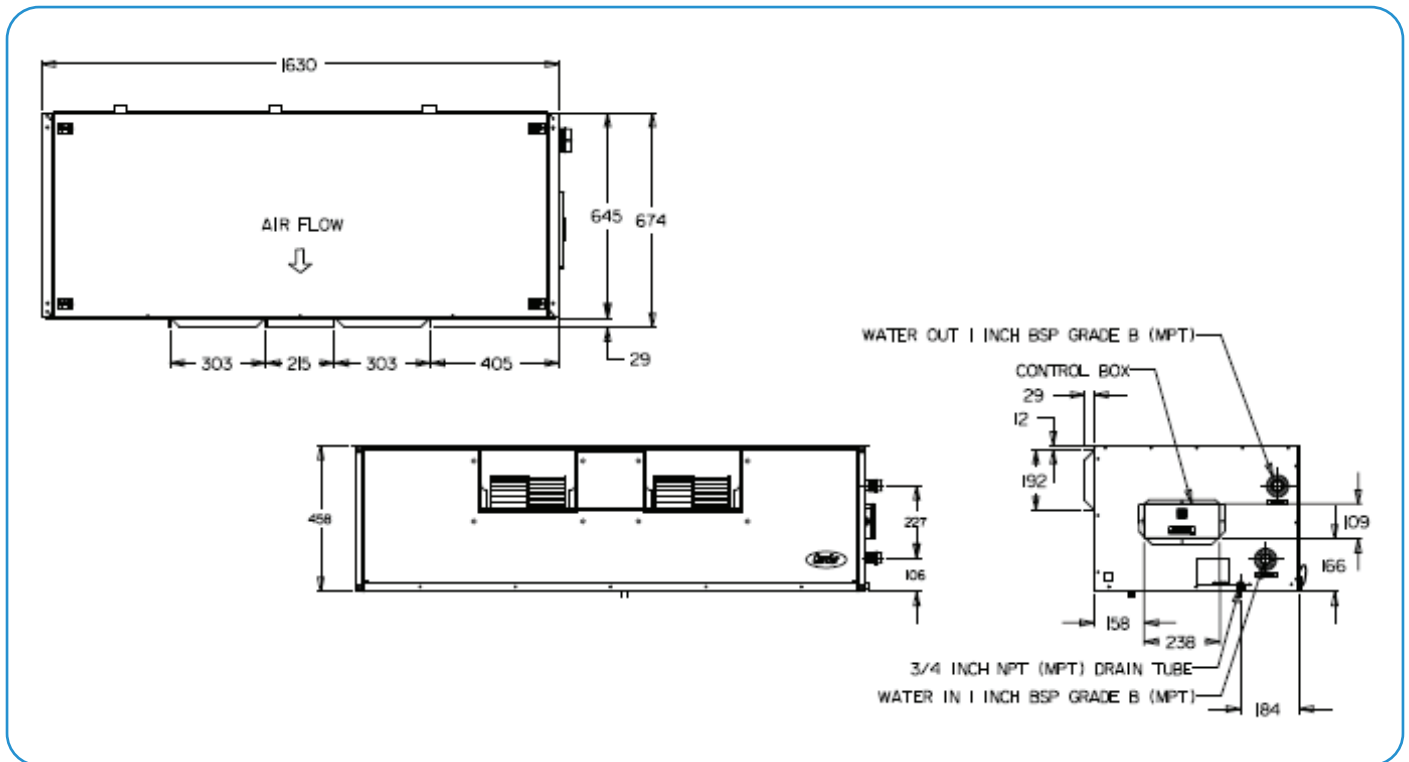

40LM150

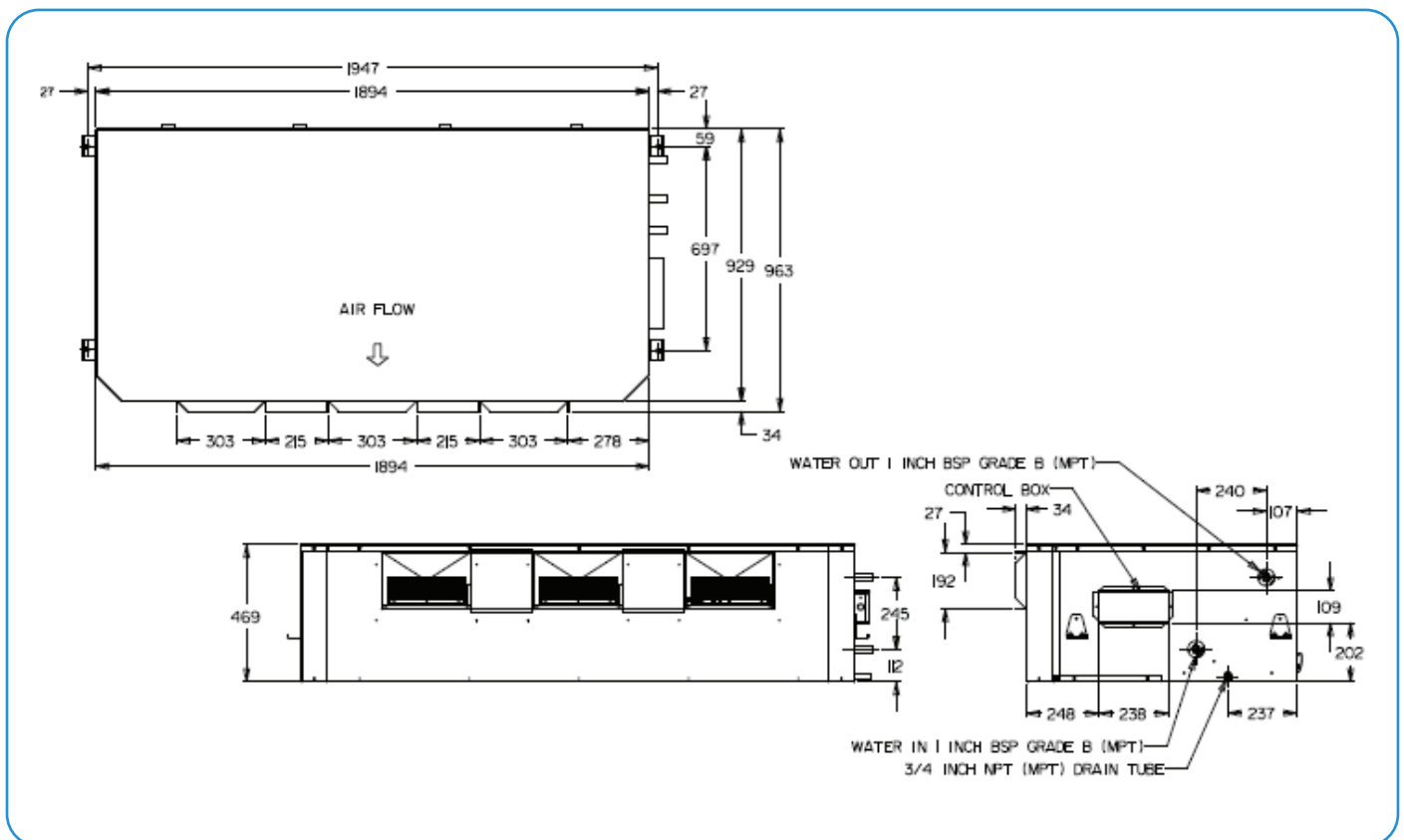

Physical Dimensions

40LM200

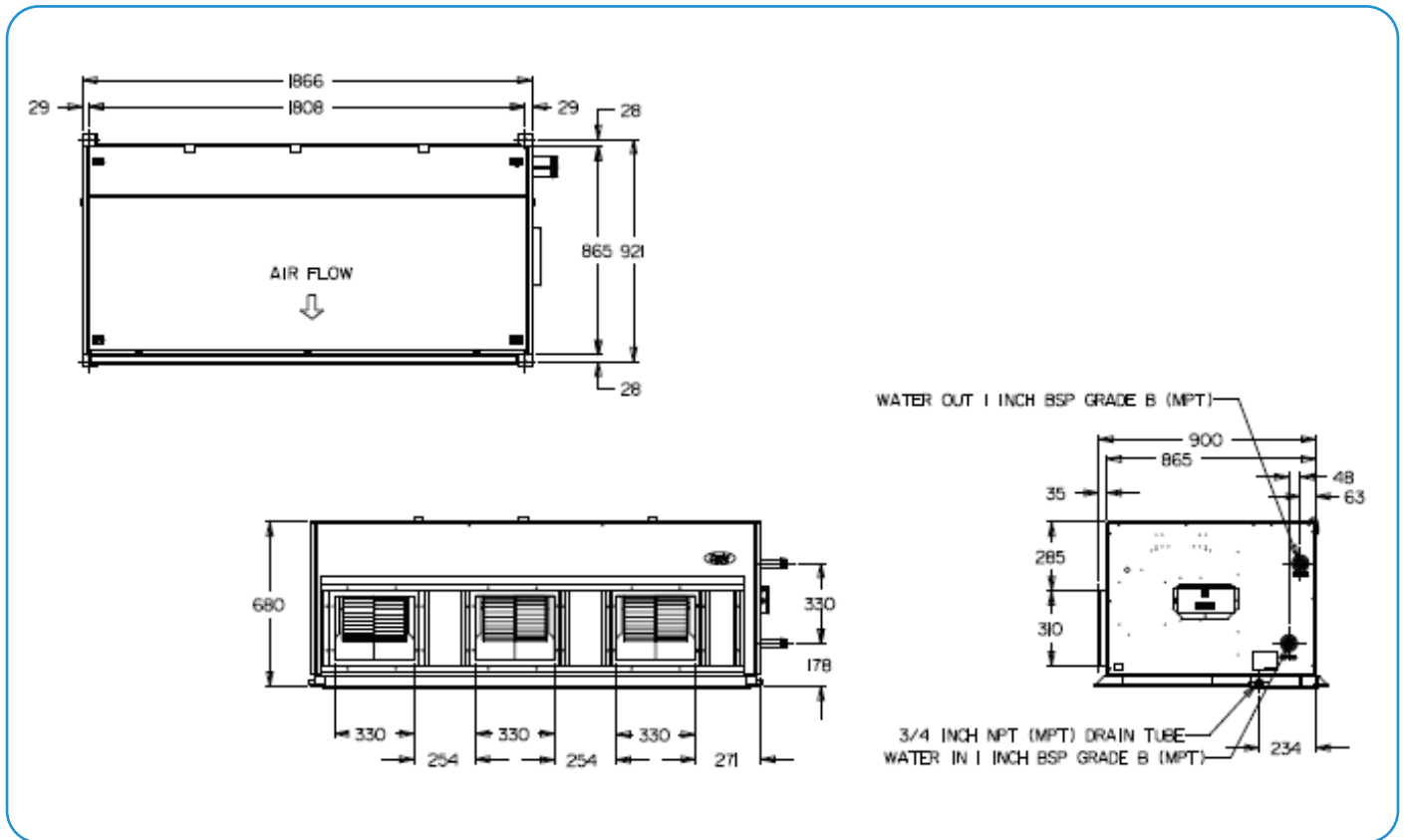

Preliminary Checks

Ensure installation personnel are familiar with each of the following requirements before installing the unit:



Space Requirement and Clearance

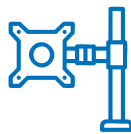

Ceiling or Mounting Strength

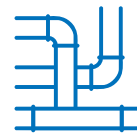

Piping Connections

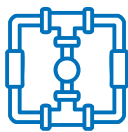

Condensate Drain Connection



Power Supply and Wiring

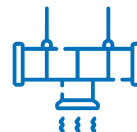

Air Duct Connections

Location, Mounting and Isolation

The unit should be installed for horizontal discharge only. Suspend the unit horizontally using factory-provided holes located on the top side flanges.

Do not restrict service areas. Refer to the diagram on the side for the recommended minimum clearance space.

Note: Clearance space beneath the unit may be levied provided the ceiling offers sufficient access for servicing and maintenance.

Select and adjust vibration isolators and suspension rods to ensure the unit is uniformly suspended. Please refer to the table for the approximate unit weight and check if ceiling strength is sufficient to support the unit load.

Ductwork should be installed according to the Carrier System Design Manual and all applicable codes. Use flexible connections to minimize duct-to-unit alignment problems and reduce vibration and noise transmission.

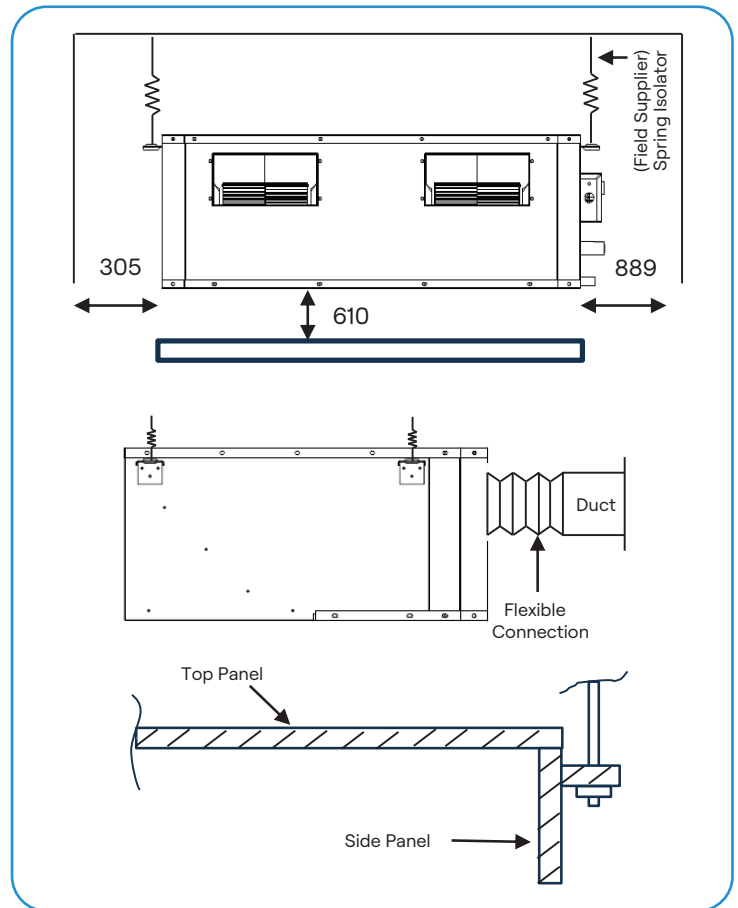

Wiring Specifications

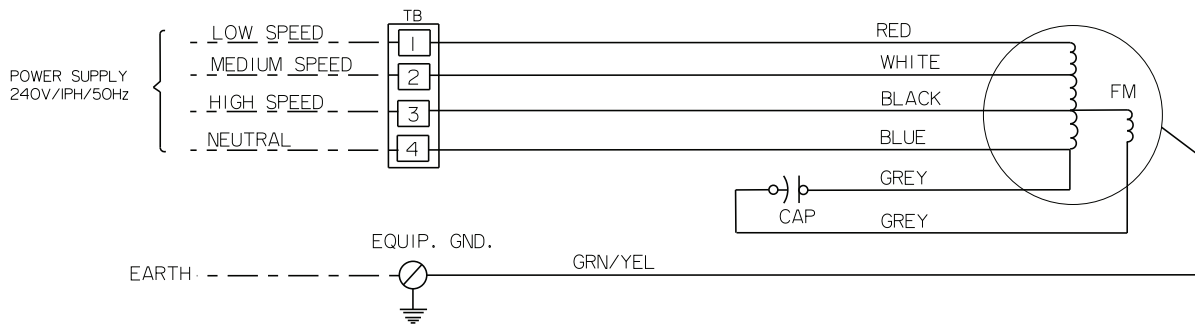

NOTE: FAN MOTOR IS INTERNALLY PROTECTED.

LEGEND:

- CAP - CAPACITOR
- FM - FAN MOTOR
- TB - TERMINAL BLOCK
- - - FIELD WIRING
- — — FACTORY WIRING
- ⊕ - EQUIPMENT GROUND

40LM540-001

More than a century of cool

In 1902, a determined engineer answered one of mankind's most nagging questions: How do we make hot, sticky, indoor air go away? In creating the world's first modern air conditioning system, Willis Carrier forever changed indoor life, and, more than a century later, the corporation that bears his name takes inspiration from his example.

Carrier strives to improve on our founder's breakthroughs, introducing new technologies that make life at home even cooler. Today, a nationwide network of experts continues to advance Willis Carrier's lifework. Your expert Carrier dealer is equipped to evaluate your home and create a customized system designed around your lifestyle.



Trụ Sở Chính : Phòng 1101, Tầng 11, Tòa nhà Centre Point, 106 Nguyễn Văn Trỗi, Phường 08, Quận Phú Nhuận, TP Hồ Chí Minh
VP Chi Nhánh: Lầu 16, Toà nhà Việt, 1 Thái Hà, Phường Trung Liệt, Quận Đống Đa, Hà Nội
VP Chi Nhánh: Lầu 3, Toà nhà Đường Việt, 30 Nguyễn Hữu Thọ, Phường Hoà Thuận Tây, Quận Hải Châu, Đà Nẵng

ĐT: (84-28) 39991670
ĐT: (84-24) 38247684
ĐT: (84-236) 3747977